

WHO Expert Committee on Specifications for Pharmaceutical Preparations

Fifty-sixth report



World Health
Organization

The World Health Organization was established in 1948 as a specialized agency of the United Nations serving as the directing and coordinating authority for international health matters and public health. One of WHO's constitutional functions is to provide objective and reliable information and advice in the field of human health, a responsibility that it fulfils in part through its extensive programme of publications.

The Organization seeks through its publications to support national health strategies and address the most pressing public health concerns of populations around the world. To respond to the needs of Member States at all levels of development, WHO publishes practical manuals, handbooks and training material for specific categories of health workers; internationally applicable guidelines and standards; reviews and analyses of health policies, programmes and research; and state-of-the-art consensus reports that offer technical advice and recommendations for decision-makers. These books are closely tied to the Organization's priority activities, encompassing disease prevention and control, the development of equitable health systems based on primary health care, and health promotion for individuals and communities. Progress towards better health for all also demands the global dissemination and exchange of information that draws on the knowledge and experience of all WHO's Member countries and the collaboration of world leaders in public health and the biomedical sciences.

To ensure the widest possible availability of authoritative information and guidance on health matters, WHO secures the broad international distribution of its publications and encourages their translation and adaptation. By helping to promote and protect health and prevent and control disease throughout the world, WHO's books contribute to achieving the Organization's principal objective – the attainment by all people of the highest possible level of health.

The *WHO Technical Report Series* makes available the findings of various international groups of experts that provide WHO with the latest scientific and technical advice on a broad range of medical and public health subjects. Members of such expert groups serve without remuneration in their personal capacities rather than as representatives of governments or other bodies; their views do not necessarily reflect the decisions or the stated policy of WHO.

To purchase WHO publications, please contact: WHO Press, World Health Organization, 20 Avenue Appia, 1211 Geneva 27, Switzerland; email: bookorders@who.int; order on line: <http://apps.who.int/bookorders>.

WHO Technical Report Series
1044

WHO Expert Committee on Specifications for Pharmaceutical Preparations

Fifty-sixth report

This report contains the collective views of an international group of experts and does not necessarily represent the decisions or the stated policy of the World Health Organization



**World Health
Organization**

WHO Expert Committee on Specifications for Pharmaceutical Preparations: fifty-sixth report

(WHO Technical Report Series, No. 1044)

ISBN 978-92-4-006382-2 (electronic version)

ISBN 978-92-4-006383-9 (print version)

ISSN 0512-3054

© World Health Organization 2022

Some rights reserved. This work is available under the Creative Commons Attribution-NonCommercial-ShareAlike 3.0 IGO licence (CC BY-NC-SA 3.0 IGO; <https://creativecommons.org/licenses/by-nc-sa/3.0/igo>).

Under the terms of this licence, you may copy, redistribute and adapt the work for non-commercial purposes, provided the work is appropriately cited, as indicated below. In any use of this work, there should be no suggestion that WHO endorses any specific organization, products or services. The use of the WHO logo is not permitted. If you adapt the work, then you must license your work under the same or equivalent Creative Commons licence. If you create a translation of this work, you should add the following disclaimer along with the suggested citation: "This translation was not created by the World Health Organization (WHO). WHO is not responsible for the content or accuracy of this translation. The original English edition shall be the binding and authentic edition".

Any mediation relating to disputes arising under the licence shall be conducted in accordance with the mediation rules of the World Intellectual Property Organization (<http://www.wipo.int/amc/en/mediation/rules/>).

Suggested citation. WHO Expert Committee on Specifications for Pharmaceutical Preparations: fifty-sixth report. Geneva: World Health Organization; 2022 (WHO Technical Report Series, No. 1044). Licence: [CC BY-NC-SA 3.0 IGO](https://creativecommons.org/licenses/by-nc-sa/3.0/igo).

Cataloguing-in-Publication (CIP) data. CIP data are available at <http://apps.who.int/iris>.

Sales, rights and licensing. To purchase WHO publications, see <http://apps.who.int/bookorders>. To submit requests for commercial use and queries on rights and licensing, see <https://www.who.int/copyright>.

Third-party materials. If you wish to reuse material from this work that is attributed to a third party, such as tables, figures or images, it is your responsibility to determine whether permission is needed for that reuse and to obtain permission from the copyright holder. The risk of claims resulting from infringement of any third-party-owned component in the work rests solely with the user.

General disclaimers. The designations employed and the presentation of the material in this publication do not imply the expression of any opinion whatsoever on the part of WHO concerning the legal status of any country, territory, city or area or of its authorities, or concerning the delimitation of its frontiers or boundaries. Dotted and dashed lines on maps represent approximate border lines for which there may not yet be full agreement.

The mention of specific companies or of certain manufacturers' products does not imply that they are endorsed or recommended by WHO in preference to others of a similar nature that are not mentioned. Errors and omissions excepted, the names of proprietary products are distinguished by initial capital letters.

All reasonable precautions have been taken by WHO to verify the information contained in this publication. However, the published material is being distributed without warranty of any kind, either expressed or implied. The responsibility for the interpretation and use of the material lies with the reader. In no event shall WHO be liable for damages arising from its use.

This publication contains the collective views of an international group of experts and does not necessarily represent the decisions or the policies of WHO.

Layout by Interligar - Branding & Design

Contents

Abbreviations	vi
WHO Expert Committee on Specifications for Pharmaceutical Preparations	viii
Declarations of interest	xiv
OPEN SESSION	1
Introduction and welcome	1
I. ECSPS procedures and processes	1
II. Update on new guidelines, norms and standards	2
III. Technical agenda topics of the fifty-sixth ECSPS	2
IV. Points of discussion	3
PRIVATE AND CLOSED SESSIONS	5
Opening	5
Election of chairpersons and rapporteurs	6
Participation in ECSPS meetings	6
1. General policy	7
1.1 Process for development of WHO norms and standards	7
2. General updates and matters for information	8
2.1 Expert Committee on Biological Standardization	8
2.2 Expert Committee on the Selection and Use of Essential Medicines	9
2.3 Prequalification of medicines	10
2.4 Member State Mechanism and post-market surveillance	11
2.5 International Conference of Drug Regulatory Authorities	12
3. Quality assurance: collaboration initiatives	14
3.1 International Meeting of World Pharmacopoeias	14
4. Nomenclature, terminology and databases	15
4.1 International nonproprietary names for pharmaceutical substances	15
4.2 Quality assurance terminology	16
4.3 Guidelines and guidance texts adopted by the ECSPS	16
5. Quality control: national laboratories	17
5.1 External Quality Assurance Assessment Scheme	17
5.1.1 Final report on EQAAS phase 10	17
5.1.2 Update on EQAAS phase 11	18
6. Quality control: specifications and tests	19
6.1 <i>The International Pharmacopoeia</i>	19
6.1.1 Workplan 2022–2023	19
6.2 General chapters	21
6.2.1 Chromatography	21

6.3	Specifications and draft monographs for medicines, including paediatrics and candidate medicines for COVID-19	21
6.3.1	COVID-19 therapeutics	21
6.3.2	Medicines for maternal, newborn, child and adolescent health	23
6.3.3	Antimalarial medicines	23
6.3.4	Antituberculosis medicines	24
6.3.5	Antiviral medicines, including antiretrovirals	25
6.3.6	Other medicines	27
6.4	Update on the virtual consultations on screening technologies, laboratory tools and pharmacopoeial specifications	27
7.	Quality control: international reference materials	29
7.1	Update on International Chemical Reference Substances	29
8.	Quality assurance: good manufacturing practices and inspection	30
8.1	Good manufacturing practices for sterile pharmaceutical products	30
8.2	Good manufacturing practices for investigational radiopharmaceutical products	31
8.3	Guidelines on technology transfer in pharmaceutical manufacturing	32
8.4	Good manufacturing practices for medicinal gases	33
8.5	Good practices for research and development facilities	34
8.6	Good manufacturing practices for investigational products	35
8.7	Recommendations from the virtual consultation on good practices for health products manufacture and inspection	36
9.	Quality assurance: distribution and supply chain	37
9.1	Setting remaining shelf-life for supply and procurement of emergency health kits	37
9.2	WHO/UNFPA guidance on natural rubber latex condom stability studies	37
9.3	WHO/UNFPA technical specification for TCu380A intrauterine device	38
10.	Regulatory guidance and model schemes	40
10.1	WHO Biowaiver List: proposal to waive in vivo bioequivalence requirements for medicines included in the EML	40
10.2	WHO guidance on registration requirements to establish interchangeability for multisource (generic) products	42
10.3	Update on WHO-listed authorities	44
10.4	WHO Certification Scheme on the quality of pharmaceutical products moving in international commerce	45
10.5	Recommendations from the virtual consultation on regulatory guidance for multisource products	45
10.6	Ongoing activities and proposed new topics for regulatory guidance and model schemes	46
11.	Miscellaneous: update on COVID-19 activities	48
11.1	Therapeutic specifications	48
11.2	Existing guidance	48
11.3	New activities	49
12.	Closing remarks	50
13.	Summary and recommendations	51
13.1	Guidelines and decisions adopted and recommended for use	51

13.2	Texts adopted for inclusion in <i>The International Pharmacopoeia</i>	52
13.2.1	General chapters	52
13.2.2	Monographs	52
13.2.3	International Chemical Reference Substances (ICRS)	53
13.3	Recommendations	53
13.3.1	<i>The International Pharmacopoeia</i>	54
13.3.2	Quality control: national laboratories	54
13.3.3	Good manufacturing practices and related areas	54
13.3.4	Distribution and supply chain	55
13.3.5	Regulatory mechanisms	55
13.3.6	Other	55
	Acknowledgements	56
	References	66
	Annex 1	
	Guidelines and guidance texts adopted by the Expert Committee on Specifications for Pharmaceutical Preparations	69
	Annex 2	
	WHO good manufacturing practices for sterile pharmaceutical products	87
	Annex 3	
	IAEA/WHO guideline on good manufacturing practices for investigational radiopharmaceutical products	171
	Annex 4	
	WHO guidelines on technology transfer in pharmaceutical manufacturing	197
	Annex 5	
	WHO good manufacturing practices for medicinal gases	225
	Annex 6	
	WHO good practices for research and development facilities of pharmaceutical products	251
	Annex 7	
	WHO good manufacturing practices for investigational products	277
	Annex 8	
	Points to consider for setting the remaining shelf-life of medical products upon delivery	301
	Annex 9	
	WHO/UNFPA guidance on natural rubber latex male condom stability studies	315
	Annex 10	
	WHO/UNFPA technical specification for TCU380A intrauterine device	333
	Annex 11	
	WHO Biowaiver List: proposal to waive in vivo bioequivalence requirements for WHO Model List of Essential Medicines immediate-release, solid oral dosage forms	403



Abbreviations

API	active pharmaceutical ingredient
BCS	Biopharmaceutics Classification System
EAP	Expert Advisory Panel on <i>The International Pharmacopoeia</i> and Pharmaceutical Preparations
ECBS	Expert Committee on Biological Standardization
ECSP	Expert Committee on Specifications for Pharmaceutical Preparations
eCTD	electronic Common Technical Document
EDQM	European Directorate for the Quality of Medicines and HealthCare
EML	WHO Model List of Essential Medicines
EMLc	WHO Model List of Essential Medicines for Children
EQAAS	External Quality Assurance Assessment Scheme
GMP	good manufacturing practices
IAEA	International Atomic Energy Agency
ICDRA	International Conference of Drug Regulatory Authorities
ICH	International Council for Harmonisation of Technical Requirements for Pharmaceuticals for Human Use
ICRS	International Chemical Reference Substance
IMWP	International Meeting of World Pharmacopoeias
INN	international nonproprietary name
mAb	monoclonal antibody
mRNA	messenger ribonucleic acid
MSM	Member State Mechanism
PIC/S	Pharmaceutical Inspection Co-operation Scheme
PQCL	pharmaceutical quality control laboratory
PQT/INS	WHO Prequalification Team for Inspection Services
PQT/MED	WHO Prequalification Team for Medicines Assessment
rpm	rotations per minute

SoINN	School of International Nonproprietary Names
SRA	stringent regulatory authority
UNEP	United Nations Environment Programme
UNFPA	United Nations Population Fund
WHO	World Health Organization
WLA	WHO-listed authority

WHO Expert Committee on Specifications for Pharmaceutical Preparations

The open session of the Fifty-sixth Expert Committee on Specifications for Pharmaceutical Preparations was coordinated from WHO headquarters, Geneva, and took place virtually on 12 April 2022

Participants¹

The open session was attended by members of the Expert Committee, technical advisers and WHO staff, as well as the following non-state actors.

Dr Nick Cappuccino, Chair, Science Committee, International Generic and Biosimilar Medicines Association, Geneva, Switzerland

Dr Sérgio Cavalheiro Filho, International Federation of Pharmaceutical Manufacturers and Associations, Geneva, Switzerland

Ms Christa Cepuch, Médecins Sans Frontières (MSF), Geneva, Switzerland

Mr Ying-Tsun Chen, Chairperson of Public Health, International Pharmaceutical Students' Federation, The Hague, Netherlands

Ms Sandrine Cloëz, Specialist, Pharmaceutical Products, Global Fund, Geneva, Switzerland

Ms Courtenay Anne Dusenbury, Director of Global and Federal Affairs, Task Force for Global Health, Decatur, United States of America (USA)

Mr Mohamed Eissa, Liaison Officer for Public Health Issues, International Federation of Medical Students' Associations, Copenhagen, Denmark

Professor Walid Habre, World Federation of Societies of Anesthesiologists, London, United Kingdom of Great Britain and Northern Ireland (United Kingdom)

¹ Unable to attend: Mr Baba Aye and Mr Herbert Beck, Public Services International, Ferney-Voltaire, France; Ms Jane Barratt, International Federation on Ageing, Toronto, Canada; Professor William Carroll, World Federation of Neurology, London, United Kingdom; Dr Kelly Catlin, Clinton Health Access Initiative, Boston, USA; Mr Jeremy Farrar, Wellcome Trust, London, United Kingdom; Professor Kostas Fountoulakis, World Psychiatric Association, Thessaloniki, Greece; Mr Charles Gore, Medicines Patent Pool Foundation, Geneva, Switzerland; Ms Anne Maryse K'habore, Association Africaine des Centrales d'Achats de Médicaments Essentiels, Ouagadougou, Burkina Faso; Mr Ibrahim Kahn, International Federation of Medical Students' Associations, Copenhagen, Denmark; Ms Marion Laumonier, Drugs for Neglected Diseases Initiative, Geneva, Switzerland; Dr Joanna Laurson-Doube, Multiple Sclerosis International Federation, London, United Kingdom; Mr Marco Marchetti, Health Technology Assessment International, Edmonton, Canada; Mr David Mukanga, Bill and Melinda Gates Foundation, Seattle, USA; Dr Rui Nakamura, World Medical Association, Ferney-Voltaire, France; Dr Lila Raj Puri, Fred Hollows Foundation, Rosebery, Australia; Mr David Reddy, Medicines for Malaria Venture, Geneva, Switzerland; Dr Roxana Rustomjee and Mr Paul L. Smock, Sabin Vaccine Institute, Washington, USA; Ms Victoria Rutter, Commonwealth Pharmacists Association, London, United Kingdom; Mr John Spangler, Rockefeller Foundation, New York, USA; Ms Malvika Vyas, European Society for Medical Oncology, Geneva, Switzerland; Mr Shalini Jayasekar Zürn, Union for International Cancer Control, Geneva, Switzerland.

Ms Padma Kamath, Director, Regulatory and Scientific Affairs, Global Self-Care Federation, Nyon, Switzerland

Ms Isabel Lucas-Manzano, International Pharmacist Coordinator, MSF, Geneva, Switzerland

Mr Murray Lumpkin, Bill and Melinda Gates Foundation, Seattle, USA

Dr Kevin Moore, Senior Manager, Pharmacopeial Collaboration, US Pharmacopeia, Rockville, USA

Dr Nigorsulton Muzafarova, Lead Product Quality Officer, Stop TB Partnership, Geneva, Switzerland

Professor John Prior, Liaison Officer, World Federation of Nuclear Medicine and Biology (WFNB), Vienna, Austria

Dr Lembit Rägo, Secretary-General, Council for International Organizations of Medical Sciences (CIOMS), Geneva, Switzerland

Dr Valérie Solbes, Pharmacy Quality Advisor, Médecins du Monde, Paris, France

The main session of the fifty-sixth Expert Committee on Specifications for Pharmaceutical Preparations was coordinated from WHO headquarters, Geneva, and took place virtually from 25 April to 2 May 2022

Members²

Dr Nadia Rashed Ali Al Mazrouei, Sharja, United Arab Emirates

Professor Marius Brits, Potchefstroom, South Africa

Dr Varley Dias Sousa, Brasília, Brazil

Dr Petra Doerr, Strasbourg, France (*Chair*)

Professor Ines Fradi, Monastir, Tunisia

Ms Mónica Hirschhorn, Montevideo, Uruguay

Professor Eliangiringa Kaale, Dar es Salaam, United Republic of Tanzania (*Rapporteur*)

Dr Adrian Krauss, Canberra, Australia (*Co-Chair*)

Dr Min Yong Low, Singapore

Ms Gugu Nolwandle Mahlangu, Harare, Zimbabwe

Ms Lynda M. Paleshnuik, Ottawa, Canada

Dr Budiono Santoso, Yogyakarta, Indonesia

Dr Daisaku Sato, Tokyo, Japan

² Unable to participate: Dr Habib Abboud, Damascus, Syrian Arab Republic.

Dr Luisa Stoppa, Rome, Italy (*Rapporteur*)

Dr Adriaan J. Van Zyl, George, South Africa

Dr Mingzhe Xu, Beijing, China

Technical advisers³

Professor Erwin Adams, Leuven, Belgium

Professor Maria Del Val Bermejo Sanz, Valencia, Spain

Dr Rubina Bose, New Delhi, India

Dr John Gordon, Nova Scotia, Canada

Professor John H. McB. Miller, Ayr, United Kingdom

Dr Jochen Norwig, Bonn, Germany

Dr Stéphanie Parra, Ottawa, Canada

Professor Gerhard Scriba, Jena, Germany

Professor Kaouther Zribi, Monastir, Tunisia

Representation from intergovernmental organizations⁴

European Directorate for the Quality of Medicines and HealthCare (EDQM), Council of Europe

Dr Andrea Lodi, Head of Laboratory Department, Strasbourg, France

European Medicines Agency (EMA)

Mr Roberto Conocchia, Good Manufacturing Practices Technical Lead, Amsterdam, Netherlands

International Atomic Energy Agency (IAEA)

Ms Aruna Korde, Radiopharmaceutical Scientist, Vienna, Austria; and Ms Celina I. Horak, Section Head, Vienna, Austria

United Nations Children's Fund (UNICEF)

Dr Peter Svarrer Jakobsen, Quality Assurance Specialist, Copenhagen, Denmark

United Nations Population Fund (UNFPA)

Ms Linda Serwaa, Technical Specialist, Copenhagen, Denmark; Ms Danielle Jurman, Humanitarian Supplies Analyst, Copenhagen, Denmark; and Dr William Potter, Consultant to UNFPA

³ Unable to participate: Ms Togi Junice Hutadjulu, Jakarta, Indonesia; Representative from Medicines and Healthcare products Regulatory Agency, London, United Kingdom; Professor Hidehiko Nakagawa, Aichi, Japan; Dr Nobumasa Nakashima, Tokyo, Japan; Professor Giovanni M. Pauletti, St Louis, USA; Ms Jacqueline N.O. Rodgers, Accra, Ghana; Dr V.G. Somani, New Delhi, India; Dr Natércia Simoes, Lisbon, Portugal.

⁴ Unable to participate: European Commission, United Nations Development Programme (UNDP), United Nations Industrial Development Organization (UNIDO), World Intellectual Property Organization (WIPO), World Trade Organization (WTO).

World Customs Organization (WCO)

Ms Alexandra Kelaidopoulou, Technical Attaché for Tariff and Trade Affairs (Nomenclature),
Brussels, Belgium

State actors (pharmacopoeias)⁵

Farmacopea Argentina

Dr Melina Assalone, Buenos Aires, Argentina

Farmacopeia Brasileira

Dr Flávia Neves Rocha Alves, Health Regulatory Agency, Brasília, Brazil

British Pharmacopoeia

Ms Helen Corns, Medicines and Healthcare products Regulatory Agency, London, United
Kingdom

European Pharmacopoeia (also representing EDQM, Council of Europe)

Dr Andrea Lodi, EDQM, Strasbourg, France

Japanese Pharmacopoeia

Dr Yukihiko Goda, National Institute of Health Sciences, Tokyo, Japan

Pharmacopoeia of the Republic of Korea

Dr Sang Aeh Park, Ministry of Food and Drug Safety, Chungcheongbuk-do, Republic of
Korea

Mexican Pharmacopoeia

Dr Ubaldo Juárez-Sevilla and Dr Rafael Hernández Medina, Comisión Permanente de la
Farmacopea de los Estados Unidos Mexicanos

State Pharmacopoeia of the Russian Federation

Dr Elena Kovaleva and Ms Olga Gubareva, Federal State Budgetary Institution, Moscow,
Russian Federation

World Health Organization

Access to Medicines and Health Products (MHP/MHA)

Dr Mariângela Simão, Assistant Director-General

Health Products Policy and Standards (MHP/HPS)

Dr Clive Ondari, Director

Norms and Standards for Pharmaceuticals (NSP)

Dr Luther Gwaza, Team Lead and Secretary of the Expert Committee

Dr Herbert Schmidt, Technical Officer

Dr Steve Estevão Cordeiro, Technical Officer

Ms Sinéad Jones, Administrative Assistant

⁵ Unable to participate: Pharmacopoeia of the People's Republic of China, Indian Pharmacopoeia, Indonesian Pharmacopoeia, Pharmacopoeia of Ukraine.

Norms and Standards for Biological Products (NSB)

Dr Ivana Knezevic, Team Lead

Dr Dianliang Lei, Scientist

Ms Sue Jenner, Administrative Assistant

Ms Christine Pasztor, Administrative Assistant

Essential Medicines (EML)

Dr Benedikt Huttner, Team Lead

Local Production and Assistance (LPA)

Dr Jicui Dong, Programme Manager

MHP/RPQ/PQT

Mr Deus Mubangizi, Unit Head, Prequalification

Prequalification Inspection Services (PQT/INS)

Dr Joey Gouws, Team Lead

Mr Mustapha Chafai, Technical Officer

Dr Xingyu Chen, Technical Officer

Ms Stephanie Croft, Technical Officer

Mr Vimal Sachdeva, Technical Officer

Prequalification Medicines Assessment (PQT/MED)

Mr Lawrence Nzumbu, Technical Officer

Mr Wondiyfraw Zeleke Worku, Technical Officer

Ms Hua Yin, Technical Officer

MHP/RPQ/REG

Mr Hiiti Sillo, Unit Head, Regulation and Safety

Incidents and SF (REG/ISF)

Mr Rutendo Kuwana, Team Lead

Ms Diana Lee, Technical Officer

Laboratory Networks and Services (REG/LNS)

Dr Gaby Vercauteren, Senior Advisor

Mr Percy Muzorori, Technical Officer

Regulatory Convergence and Networks (REG/RCN)

Dr Samvel Azatyan, Team Lead

Regulatory Systems Strengthening (REG/RSS)

Dr Alireza Khadem Broojerdi, Scientist

Country Readiness Strengthening

Ms Laura Alejandra Velez Ruiz Gaitan, Technical Officer, Health Care Readiness

UHL/Sexual and Reproductive Health and Research

Dr Petrus Steyn, Scientist, Contraception and Fertility Care

Procurement and supply services

Ms Sophie Laroche, Quality Officer, Global Supply Policies

Report writer

Dr Sian Lewis, London, United Kingdom

Representation from WHO Regional Offices⁶

Regional Office for the Americas

Mr Murilo Freitas Dias

Regional Office for Europe

Dr Dorina Pirgari

Regional Office for South-East Asia

Ms Uhjin Kim and Dr Adrien Inoubli

⁶ Unable to participate: Regional Office for Africa, Regional Office for the Eastern Mediterranean, Regional Office for the Western Pacific.

Declarations of interest

Declarations of interest made by members of the WHO Expert Committee on Specifications for Pharmaceutical Preparations and temporary advisers are listed below.

Dr H. Abboud, Professor E. Adams, Dr N.R. Al Mazrouei, Dr R. Bose, Professor I. Fradi Dridi, Dr P. Doerr, Dr J. Gordon, Ms M. Hirschhorn, Professor E.A. Kaale, Dr A. Krauss, Dr M.Y. Low, Ms G.N. Mahlangu, Professor J.H.McB. Miller, Dr J. Norwig, Ms L. Paleshnuik, Dr G.M. Pauletti, Dr B. Santoso, Dr D. Sato, Professor G. Scriba, Dr V.G. Somani, Dr L. Stoppa, Dr M. Xu, and Dr K. Zribi reported no conflict of interest.

Professor M.D.V. Bermejo Sanz reported consulting on dissolution studies or pharmacokinetics to pharmaceutical companies and research support, including grants, collaboration, sponsorships and other funding. This disclosure does not constitute a conflict of interest as the meeting will not discuss specific products manufactured by pharmaceutical companies.

Professor M. Brits reported employment as Director of the WHO Collaborating Centre for the Quality Assurance of Medicines at North-West University, a non-state actor, consulting with other national regulatory authorities, acting as technical adviser to WHO, providing expert opinion on the comparability of active pharmaceutical ingredients from different manufacturers to the South African Health Products Regulatory Authority, and acting as a member of the British Pharmacopoeia EC2 group. This disclosure does not constitute a conflict of interest on the topics for the meeting.

Dr V. Dias Sousa reported employment by the Brazilian Health Regulatory Agency (ANVISA), a state actor. This disclosure does not constitute a conflict of interest.

Dr S. Parra reported employment by Health Canada, a state actor. This disclosure does not constitute a conflict of interest.

Dr A.J. Van Zyl reported working as an independent consultant and auditor to assess compliance with good manufacturing practices for the pharmaceutical industry and organizing training workshops. This disclosure does not constitute a conflict of interest as these companies do not manufacture any specific product linked to the topic of the meeting.

OPEN SESSION

This open session was attended by members of the Expert Committee on Specifications for Pharmaceutical Preparations (ECSP) and 16 non-state actors. It was held virtually, before the private and closed ECSP sessions, on 12 April 2022.

Introduction and welcome

Dr Clive Ondari, Director of Health Products Policy and Standards, World Health Organization (WHO), welcomed all participants to the open session for non-state actors. He emphasized the ECSP's aim of providing information in a transparent way and highlighted the value of open sessions as a way of receiving input from key stakeholders on the work of the Expert Committee.

Dr Ondari introduced the ECSP's standard-setting work, which covered quality assurance of medicines, regulatory guidance, good practices, the WHO model scheme and quality control specifications. The Expert Committee had first been convened in 1947, since when it had continued to provide Member States with recommendations on norms and standards, even during the COVID-19 pandemic, to ensure the production, supply, storage, distribution and use of quality-assured, safe and efficacious essential medicines.

The ECSP's decisions impacted the quality of medicines that were very widely used. In that regard, it served not only WHO Member States but also a range of programmes within WHO, as well as other international organizations.

Dr Ondari handed the floor to Dr Daisaku Sato, Expert Committee member and Director of the Compliance and Narcotics Division in the Ministry of Health, Labour and Welfare of Japan, to moderate the open session.

I. ECSP procedures and processes

Dr Luther Gwaza, Team Lead of the WHO Norms and Standards for Pharmaceuticals Team and Secretary of the Expert Committee, gave a brief overview of ECSP procedures and processes.

Like all WHO expert committees, the ECSP was governed by strict rules and procedures, which were set out in the WHO basic documents. ECSP members were selected from the WHO Expert Advisory Panel on *The International Pharmacopoeia* and Pharmaceutical Preparations (EAP), based on education, background and experience, and following an official nomination process.

The Expert Committee met once a year to discuss and provide recommendations on quality assurance and control for pharmaceuticals. All norms, standards and guidelines reviewed at ECSP meetings were developed in consultation with members of the EAP and a wide range of national

and international partners, including national authorities, international organizations, non-state actors, specialists, WHO collaborating centres, pharmacopoeia authorities, and regional and interregional regulatory groups. All texts were also put out for public comment. If the Expert Committee decided that more work was required before adoption, the document returned to the consultation process. If it decided a consensus had been formed, the guideline was adopted and published in an annex to the Expert Committee's meeting report, where it became WHO technical guidance. The report was then presented by the WHO Director-General to the Executive Board and to WHO Member States for implementation.

Dr Gwaza emphasized the importance of the ECSPP's work in developing robust international norms and standards to support a global approach for dossier submissions and inspections of manufacturers; standardize critical information for procurers; promote convergence and collaboration among national regulatory authorities; and enable access to safe and effective medicines by patients.

For more information on the ECSPP's role in developing WHO norms and standards, see section 1.1 below.

II. Update on new guidelines, norms and standards

Dr Luther Gwaza gave an update on the latest guidelines, norms and standards adopted by the ECSPP, which were published in the Expert Committee's fifty-fifth meeting report.⁷ These included:

- 10 new and revised general medicines quality assurance and regulatory guidance texts;
- 15 new and revised specifications for active substances and specific dosage forms;
- 2 new and revised general chapters in *The International Pharmacopoeia*;
- 2 new International Chemical Reference Substances (ICRS).

III. Technical agenda topics of the fifty-sixth ECSPP

The WHO Secretariat to the ECSPP summarized topics on the agenda for the fifty-sixth ECSPP meeting. In particular, members of the WHO Secretariat provided:

⁷ WHO Expert Committee on Specifications for Pharmaceutical Preparations: fifty-fifth report. WHO Technical Report Series No. 1033. Geneva: World Health Organization; 2021 (<https://apps.who.int/iris/handle/10665/340323>, accessed 4 April 2022).

- an overview of *The International Pharmacopoeia*, which provided analytical methods and specifications for active pharmaceutical ingredients, finished pharmaceutical products, excipients and radiopharmaceuticals (see section 6.1);
- a list of monographs and other pharmacopoeial texts to be discussed by the ECSPP (see sections 6.2 and 6.3);
- a short summary of draft guidance on good manufacturing practices and inspection, including on sterile products, radiopharmaceuticals, medicinal gases, investigational products and shelf-life for emergency health kits (see sections 8 and 9);
- a list of key regulatory topics due to be discussed by the ECSPP, which included bioequivalence, interchangeability requirements for multisource products and an update on WHO-listed authorities (see section 10);
- an overview of the WHO Biowaiver List, which provided a proposal to waive in vivo bioequivalence requirements for selected medicines included in the WHO Model List of Essential Medicines (see section 10.1);
- a brief review of guidance that is being developed in collaboration with international partners, including the International Atomic Energy Agency (see section 8.2) and the United Nations Population Fund (see sections 9.2 and 9.3);
- an update on WHO's latest activities to support quality assurance, regulatory guidance and technical specifications of pharmaceuticals related to COVID-19 (see section 11).

Dr Gwaza emphasized WHO's commitment to providing a coherent approach for setting norms and standards and supporting their implementation so all Member States can benefit from them. The Organization aimed to ensure that all its norms and standards were globally applicable, and that they were developed to fill key gaps and address the real needs of Member States.

IV. Points of discussion

Dr Sato invited all participants of the open session to raise queries or comments about the ECSPP's work and the proposed agenda for the Expert Committee's fifty-sixth meeting. The main points of discussion were as follows.

- **Nitrosamine impurities.** Asked whether nitrosamine impurities in essential medicines were being addressed in *The International Pharmacopoeia*, the WHO Secretariat confirmed that a method to test for 1-methyl-4-nitrosopiperazine in rifampicin was under

development. Once finalized, a reference to that method would be inserted in the monograph. Similarly, 1-cyclopentyl-4-nitrosopiperazine (CPNP) would be considered in the future development of rifapentine monographs.⁸

- **Medicinal oxygen.** One participant asked whether the ECSPP would consider mixtures of oxygen in different concentrations within the newly revised monograph for medicinal oxygen. The WHO Secretariat confirmed that that point had been raised during the public consultation on the revision and had been duly considered and addressed in the draft that would be presented to the Expert Committee.
- **Input to ECSPP's work.** Participants expressed their support for the ECSPP and noted the value of the open session for informing non-state actors of the Expert Committee's work. They asked whether non-state actors could trigger updates to existing guidelines or suggest areas where new guidance would be especially useful. The WHO Secretariat confirmed that non-state actors in official relations with WHO could submit suggestions for new or revised guidance to the WHO Secretariat.

Dr Sato thanked all participants for coming and for their contributions to the meeting.

That concluded the open session.

⁸ See https://extranet.who.int/pqweb/sites/default/files/documents/FAQ_Nitrosamine_18Dec2020.pdf.

PRIVATE AND CLOSED SESSIONS

The private and closed sessions were attended by ECSPP members, technical advisers, international organizations and state actors.

The fifty-sixth meeting of the ECSPP was held (virtually) from 25 April to 2 May 2022. To maximize the efficiency of the online format, some agenda items were covered by correspondence beforehand.

Opening

The meeting was opened by Dr Mariângela Simão, Assistant Director-General of Access to Medicines and Health Products, on behalf of the WHO Director-General, Dr Tedros Ghebreyesus.

After welcoming all participants to the meeting, Dr Simão gave recognition to the Expert Committee's efforts to support the global response to the COVID-19 pandemic, which had been ongoing for the previous two years. During that time, the ECSPP had not only continued to work on priority health issues identified in previous years but had also striven to issue quality standards for new and existing therapeutics relevant to COVID-19. That action had included updating the monograph for medical oxygen and developing new monographs for molnupiravir and remdesivir. Those international standards, which had been published in *The International Pharmacopoeia*, were the only ones available worldwide for those medicines. They were essential to combat the substandard and falsified COVID-19 therapeutics that were already circulating in some parts of the world, and to increase global production capacity for quality-assured COVID-19 medicines.

Dr Simão called the pandemic a wake-up call for scientists, health professionals and governments to find ways to work more efficiently and to remain agile in the face of fast-changing, complex environments. She emphasized the need to ensure that WHO could act quickly to update requirements as new evidence became available while maintaining the highest standards and transparency in its work. To that end, WHO was looking to increase the interaction and involvement of individual experts between the ECSPP annual meetings through a series of preparatory meetings of groups of experts to support the WHO Secretariat in preparing technical documents for the ECSPP.

Dr Simão reminded participants that the World Health Assembly had long identified the expert committees as the backbone of WHO's standard-setting process. She reaffirmed the importance of ECSPP's work to achieve the "triple billion" targets that formed the foundation of WHO's Thirteenth General Programme of Work 2019–2023. She noted that the work of the Expert Committee had expanded significantly since it was first created in 1947 and

now covered the end-to-end process for pharmaceuticals to facilitate access to quality-assured, safe and efficacious essential medicines to all that needed them, wherever they lived.

Election of chairpersons and rapporteurs

The ECSPP appointed Dr Petra Doerr as chair of the meeting, Dr Adrian Krauss as co-chair and Dr Luisa Stoppa and Professor Eliangiringa Kaale as rapporteurs.

Participation in ECSPP meetings

ECSPP members had been reminded by correspondence of the rules governing participation in the ECSPP meeting, by which committee members and technical advisers were invited to participate in their personal capacities. In all cases, participation was by invitation only.

ECSPP meetings adhered to WHO procedures for expert committee meetings and included three broad types of session:

- Open sessions, for sharing information and updates. These were for non-state actors and members of the EAP. In the current year the open session had been held on 12 April, before the private and closed ECSPP sessions.
- Private sessions, during which specific monographs, guidelines and other proposed documents were discussed. These were for ECSPP members, technical advisers, international organizations and state actors.
- Closed sessions, for agreeing ECSPP recommendations and finalizing the report. These were for ECSPP members only.

All decisions by the ECSPP were taken by its members during a closed session.

The Expert Committee noted the rules.

1. General policy

1.1 Process for development of WHO norms and standards

Dr Luther Gwaza gave an overview of how WHO norms and standards were developed, and how the ECSP and *The International Pharmacopoeia (1)* fitted into that process.

Developing, establishing and promoting international standards for food, biological, pharmaceutical and similar products were part of WHO's core mandate (Article 2, WHO Constitution). WHO achieved that through expert committees that were established by the World Health Assembly or Executive Board, and that were governed through set regulations and rules of procedure.

The ECSP was responsible for WHO's guidance for medicines quality assurance, as well as regulatory standards, across the full life cycle of medicines from development to post-marketing. That included taking responsibility for more than 130 official WHO guidance texts and guidelines. The ECSP worked in close collaboration with a wide range of partners, including national and regional authorities and groupings, international organizations, professional and other associations, non-state actors, quality assurance and regulatory experts, WHO collaborating centres, and pharmacopoeial authorities and secretariats.

Dr Gwaza underscored the critical value of the ECSP's work, particularly given the importance of ensuring patients' access to safe and quality-assured medicines. That matter was important not only to WHO but also to the broader United Nations group; it featured prominently in the United Nations Sustainable Development Goals, for example.

All monographs, guidance texts, good practices, model schemes and guidelines adopted by the ECSP were developed in response to recommendations and requests from WHO governing bodies and programmes or in response to major public health needs. They were widely circulated for public comment (including two rounds of consultation for each document), reviewed by expert groups and discussed in annual ECSP meetings before they were adopted by consensus for use. In all cases, the norms and standards developed by the ECSP were intended to be tools that:

- were ready for use for adoption in national legislation;
- enabled collaboration with other authorities;
- enabled work sharing (for example, through regional networks);
- enabled reliance on decisions from other regulatory authorities and laboratories.

All decisions taken at the ECSP's annual meetings were recorded in publicly available meeting reports published as part of the WHO Technical Report Series.

The Expert Committee noted the process.

2. General updates and matters for information

Meeting participants were updated on a range of WHO activities related to the work of the Expert Committee.

2.1 Expert Committee on Biological Standardization

Dr Ivana Knezevic, Team Lead for WHO Norms and Standards for Biological Products, spoke about the latest work of the Expert Committee on Biological Standardization (ECBS). The ECBS was responsible for establishing evidence-based international norms and standards for biological products.

The latest ECBS meeting (its 75th meeting) had been held virtually in April 2022. At that meeting, the Expert Committee had recommended adopting three WHO written standards: guidelines on evaluation of biosimilars, guidelines for the production and quality control of monoclonal antibodies and related products intended for medicinal use, and a WHO manual for the preparation of reference materials for use as secondary standards in antibody testing.

The 75th ECBS had also recommended establishing five new WHO international reference materials and had discussed three main issues, as follows.

- **Standardization issues relating to the COVID-19 pandemic.** In particular, the ECBS had been informed that unprecedented global demand for the first WHO international standard for anti-SARS-CoV-2 immunoglobulin established in December 2020 had resulted in its depletion by August 2021. Candidate replacement materials were being evaluated and a replacement standard was expected to be presented to the ECBS for consideration in October 2022.
- **Animal testing requirements review.** The three-year project, which had begun in 2019 and was being conducted by an independent research institute, aimed to review all animal testing requirements and methods described in WHO guidelines on the quality control and lot release of vaccines and biotherapeutic products, especially to identify opportunities for and obstacles to adopting the principles of the 3Rs – replace, refine, reduce. The final report on the first phase of the project was expected in 2023, after which the ECBS would consider recommending a WHO position paper and guidance on incorporating the 3Rs into lot release testing.
- **WHO priorities for new and revised standards for biological products.** The ECBS had reviewed those, noting that several recently adopted standards were expected to support the COVID-19 response, for example guidance on plasmid DNA vaccines and messenger ribonucleic acid (mRNA) vaccines. It had identified

several standards that should potentially be revised because they might be outdated (for example, on oral poliomyelitis vaccines, and yellow fever, rotavirus, malaria, dengue and MMR vaccines). It had further suggested that, depending on the outcome of ongoing vaccine developments, new WHO guidelines might be required, for example on vaccines against tuberculosis, *Shigella* species, and group B streptococcus. The ECBS had also identified some general documents that might benefit from revision or amendment, including WHO guidelines on pandemic influenza preparedness, lot release, post-approval changes and the evaluation of monoclonal antibodies (mAbs) for use as biosimilars.

Following a query from ECSPP members, Dr Knezevic confirmed that the ECBS would consider, alongside other priorities, technology transfer of biological products with a view to making a proposal for developing guidance that could complement the *Guidelines on technology transfer in pharmaceutical manufacturing* adopted by the fifty-sixth ECSPP (see section 8.3).

The next ECBS meeting was scheduled for 24–28 October 2022.

Find out more at: <https://www.who.int/groups/expert-committee-on-biological-standardization>.

The Expert Committee noted the update.

2.2 Expert Committee on the Selection and Use of Essential Medicines

Dr Benedikt Huttner, Team Lead for WHO Essential Medicines, briefed participants on the work of the WHO Expert Committee on the Selection and Use of Essential Medicines, which met every two years to update the WHO Model List of Essential Medicines (EML), including the WHO Model List of Essential Medicines for Children (EMLc). There were three broad criteria for including a medicine on the list: evidence of efficacy and safety; public health relevance; and a consideration of comparative cost–effectiveness (2).

The Expert Committee had reviewed 88 applications for the 2021 update of the EML; 20 new medicines (and 23 new formulations) had been added to the EML and 17 to the EMLc. At the same time, two medicines and 13 formulations had been deleted. The Expert Committee had rejected 25 proposals for inclusion, change or deletion for 28 medicines, medicine classes or formulations.

A major area of change in the EML in recent years had been the increased emphasis on cancer medicines, with 62 of those medicines now included in the EML (and 42 in the EMLc). The Expert Committee had considered 23 applications for cancer medicines in 2021. Three new cancer medicines and several new indications for already listed cancer medicines for childhood cancers

had been recommended for addition. Among the rejected applications, several involved cancer medicines that were too highly priced, employed data that were too immature, or both.

Two other areas of change in the latest EML were highlighted by Dr Huttner. The first was medicines for diabetes, with long-acting insulin analogues added to both the EML and EMLc for treatment of patients with type 1 or 2 diabetes mellitus who were at high risk of experiencing hypoglycaemia with human insulin. The second was antibiotics, with several new formulations and indications added to both the EML and EMLc, and new guidance published on how to implement the WHO Access, Watch, Reserve (AWaRe) classification of antibiotics for evaluation and monitoring of use, 2021. A new antibiotic active against multidrug resistant bacteria had also been added to the EML.

Other additions to the 2021 EML included antituberculosis medicines, antifungals, antivirals and medicines for smoking cessation.

ECSP members discussed various aspects of the selection process for the EML and EMLc, particularly with regard to cost and cost-effectiveness criteria. Dr Huttner informed the ECSP that since those criteria had been established, the prices of many medicines – including some very effective medicines – had risen sharply, and there was a need to reassess the cost-effectiveness criteria for essential medicines. Dr Huttner further informed the ECSP that at its last meeting the Expert Committee had recommended establishing a working group to help advise WHO on policies and rules that could make highly priced essential medicines more affordable and accessible.

The next meeting of the Expert Committee on Selection and Use of Essential Medicines was scheduled for April 2023.

Find out more at: <https://www.who.int/groups/expert-committee-on-selection-and-use-of-essential-medicines>.

The Expert Committee noted the update.

2.3 Prequalification of medicines

Mr Lawrence Nzumbu, Technical Officer, WHO Prequalification Team for Medicines Assessment (PQT/MED), updated meeting participants on the latest work of PQT/MED, which worked to facilitate access to medicines that met unified standards of quality, safety and efficacy for HIV/AIDS, malaria and tuberculosis.

In 2021, 46 products had been prequalified, including several firsts. Those included products for new and recently added therapeutic areas, such as Ebola virus disease and COVID-19, as well as more established areas, including tuberculosis and HIV/AIDS. Submissions for human insulin products had also been invited but had yet to be made.

While WHO's prequalification processes had speeded up, the overall time it took for finished pharmaceutical products to achieve prequalification had increased slightly compared with the previous two years. That was largely due to delays in manufacturer submissions and responses caused by disruptions associated with the COVID-19 pandemic, such as site closures and reduced personnel.

In addition to evaluating products for prequalification, PQT/MED had supported access to prequalified medicines through collaborative mechanisms such as the new coordinated scientific advice procedure, whereby product developers might approach WHO to get advice on the most appropriate way to generate robust evidence on a product's benefits and risks for future evaluation for a WHO policy recommendation and prequalification. PQT/MED had also undertaken capacity-building activities for international assessors and manufacturers, including two workshops in 2021.

Mr Nzumbu informed the Expert Committee that assessor and manufacturer workshops would continue in 2022 and that all stakeholders could look forward to a new PQT information technology platform, which would cover all areas of prequalification activities, and which would provide a central platform for manufacturers, laboratories and regulatory authorities to access information, submit and track applications and upload documents. In addition, the introduction of the electronic Common Technical Document (eCTD) was envisaged for the end of 2022.

Find out more at: <https://extranet.who.int/pqweb/medicines>.

The Expert Committee noted the update.

2.4 Member State Mechanism and post-market surveillance

Mr Rutendo Kuwana, Team Lead for WHO Incidents and Substandard and Falsified Medical Products, summarized the Member State Mechanism (MSM), which was the political response to substandard and falsified medical products. He also updated the Expert Committee on the latest post-market surveillance activities.

The MSM focused on a range of high-level activities, including building regulatory capacities to prevent, detect and respond to substandard and falsified medical products; supporting national, regional and global knowledge exchange; improving uptake of detection technologies and traceability systems; promoting good governance; raising awareness of online distribution and sales; and developing strategies to tackle informal markets.

The MSM used a range of practical tools and tactics to support its activities, including carrying out medicine quality surveys, publishing guidance texts, sharing country experiences, issuing relevant alerts, and developing apps to enable smartphone reporting.

During 2021, there had been 43 reports of substandard and falsified COVID-19 medical products, including 16 falsified medicines and 27 substandard or falsified vaccines. Two medical product alerts were issued for falsified COVID-19 vaccines.

Other ongoing post-marketing surveillance activities to detect, assess, understand and prevent substandard and falsified medical products included antibiotic surveys in the United Republic of Tanzania, an oxytocin survey in Côte d'Ivoire and Senegal, and surveys to investigate nitrosamine impurities. Work was also ongoing to use spectrally offset raman spectroscopy (SORS) to screen and detect substandard and falsified COVID-19 vaccines, which was intended to be added to the WHO global spectral library, to be called the Medicines Special Data Analytical Solution (MeSDAS). The Expert Committee encouraged the conduct of similar surveys the WHO South-East Asia Region.

Mr Kuwana encouraged the ECSPP to consider developing a monograph for arteminol and piperazine soft gelatin capsules in *The International Pharmacopoeia*, which had been found during a recent post-marketing survey in Africa but for which there was no monograph in any of the world's pharmacopoeias. The Expert Committee noted this request.

Find out more at: <https://www.who.int/teams/regulation-prequalification/incidents-and-SF/mechanism>.

The Expert Committee noted the update.

2.5 International Conference of Drug Regulatory Authorities

Dr Samvel Azatyan, Team Lead of WHO Regulatory Convergence and Networks, presented the latest news from the International Conference of Drug Regulatory Authorities (ICDRA). ICDRA had held biennial conferences since 1980 for regulatory authorities to share information and strengthen collaboration. ICDRA was an important tool for WHO and regulatory authorities to discuss and achieve consensus on issues of international relevance, harmonize regulation, and improve the safety, efficacy and quality of medicines.

Each conference lasted four days and covered topics such as quality, biosimilars, regulatory reform, medicines safety, counterfeiting, access, regulation of clinical trials, harmonization, new technologies and e-commerce. Starting from 14th ICDRA in 2010 in Singapore, ICDRA conferences had been preceded by two days of meetings and events that were open to all concerned stakeholders, such as industry, academia, nongovernmental organizations and product development partnerships.

In September 2021, WHO had held an extraordinary (virtual) ICDRA on smart regulation – timely delivery of quality-assured medical products for all during the global pandemic. It had been attended by more than 500 people from all over the world. The conference had made several recommendations to

Member States, WHO, industry and regulatory authorities, designed to, among other things:

- continue using the Global Benchmarking Tool to enhance regulatory capacity;
- adopt best practices introduced during the pandemic to speed up regulatory procedures, including emergency approval, rolling application submissions, remote inspections and digital submissions;
- build capacity in low- and middle-income countries for regulation through reliance;
- identify and use new tools and techniques to support emergency response during the pandemic and beyond.

The next ICDRA would be hosted by the Central Drugs Standard Control Organization in India during 2023, if the COVID-19 situation allowed.

The ECSPP expressed its hope that it would be possible to hold the next ICDRA as scheduled. It also noted the growing use of electronic signatures and certificates around the world and the lack of a common platform or standard for issuing those. Dr Azatyan confirmed that the responsibility for issuing e-signatures and e-certificates fell to national certifying authorities, which made it a difficult process to centralize globally; he noted, however, that e-certificates could differ in specifics from one country to the next but still be in the general spirit of the WHO Certification Scheme on the quality of pharmaceutical products moving in international commerce.

Find out more at: <https://www.who.int/teams/regulation-prequalification/regulation-and-safety/regulatory-convergence-networks/icdra>.

The Expert Committee noted the update, including the importance of establishing a common standard for e-signatures and e-certificates.

3. Quality assurance: collaboration initiatives

3.1 International Meeting of World Pharmacopoeias

ECSP members were updated by correspondence on the latest International Meeting of World Pharmacopoeias (IMWP). Each pharmacopoeia covered a different country or region but all worked to protect public health by creating and making available public standards to help ensure the quality of medicines. Every year, they met to share experience and expertise and find ways of working together to synchronize their efforts.

In February 2021, the 12th IMWP had been hosted by WHO. Outcomes from the monthly meetings of the global pharmacopoeial alert on COVID-19 had been shared. Based on those, a proposal for establishing principles and processes for approving and publishing IMWP monographs had been presented and adopted by IMWP participants. The new processes mirrored those used for WHO good pharmacopoeial practices.

Other highlights from the meeting included:

- exchanging information on the activities of pharmacopoeias to address increased demand for and problematic supply of oxygen for COVID-19;
- publishing an IMWP monograph for favipiravir;
- agreeing to continue using the new framework for exchanging information within the Pharmacopoeial Discussion Group;
- agreeing to hold a stakeholders' meeting in 2022.

The next IMWP meeting would be hosted by the Mexican Pharmacopoeia in 2022.

Find out more at: <https://www.who.int/teams/health-product-and-policy-standards/pharmacopoeia/world-pharmacopoeias>.

The Expert Committee expressed its support for the IMWPs and its hope that the 13th meeting would be able to go ahead during the present year. It encouraged WHO to continue serving as the Secretariat for those events. The Expert Committee noted the update, including the principles and process for developing IMWP monographs and the implementation of the pharmacopoeial alert mechanism and its efforts to address questions on the quality of therapeutics in response to COVID-19.

4. Nomenclature, terminology and databases

4.1 International nonproprietary names for pharmaceutical substances

ECSP members were updated by correspondence on WHO's latest work to support the development of international nonproprietary names (INNs), which served to help identify pharmaceutical substances or active pharmaceutical ingredients (APIs). WHO collaborated closely with INN experts and national nomenclature committees to choose a single name of worldwide acceptability for each active substance that was to be marketed as a pharmaceutical. Since the turn of the century, increasing globalization and rapid scientific and technical development had fuelled a rapid rise in the number of new biological products developed and approved for use. That trend, which was expected to continue, was reflected in the growing number of INN requests received each year, which had risen from around 150 in 2000 to more than 450 in 2021.

Five major activities were highlighted in the INN update to ECSP members.

- **COVID-19 vaccine substances.** One of the recent approaches to vaccine development involved messenger RNAs (mRNA), which were well defined and so fell within the scope of the INN nomenclature system. Seven mRNA containing anti SARS CoV 2 vaccine substances had already been assigned INNs. During the 72nd Consultation on International Nonproprietary Names, a special procedure for variant COVID-19 vaccine active substances had been approved to accelerate assignment of INNs. The procedure had already been used to name Omicron-specific variant vaccine riltozinameran.
- **Improving INNs for cell therapies.** The INN cell therapy application form had been revised to include more information on the cell therapy substance, including both for substances claiming to be stem cells and for those claiming to be stromal cells. In recognition of the need to harmonize cell definitions, a white paper covering regulatory issues for cell and advanced therapies was being drafted, to be shared with all regulators.
- **School of International Nonproprietary Names (SoINN).** SoINN, a virtual school available at <https://extranet.who.int/soinn>, promoted INNs as a central teaching and learning theme for all health professionals. The school had held several online webinars and courses in the science of nomenclature and naming of pharmaceutical substances in English, French and Spanish. Work was under way to translate courses into Arabic. Since January 2022, SoINN had been visited by nearly 68 000 unique visitors.

- **Stem in a pill.** The SoINN project aimed to review all different stem cells and categorize them into pharmacological classes. It was progressing, with 22 classes completed, and 16 published on the SoINN website.
- **New INN stems for monoclonal antibodies.** In 2021, the WHO Expert Group on International Nonproprietary Names had adopted a new INN mAb nomenclature scheme for antibody-based drugs, which would replace the well known stem -mab. The new scheme divided substances with an immunoglobulin variable domain into four groups and used the following stems: -tug, -bart, -mig, and -ment.

Find out more at: <https://www.who.int/teams/health-product-and-policy-standards/inn>.

The Expert Committee noted the update and expressed its appreciation for the progress made by the priority process in response to COVID-19 and its flexibility to cover products of new modality.

4.2 Quality assurance terminology

ECSP members were reminded by correspondence that all terms and definitions used in ECSP norms, standards, guidelines and reports were published in the Quality Assurance of Medicines Terminology Database (3). The database, which was updated every year, was intended to help harmonize terminology and avoid misunderstandings that might arise from different interpretations of individual terms.

Find out more at: <https://cdn.who.int/media/docs/default-source/medicines/norms-and-standards/guidelines/mqa-terminology-sept-2020.pdf>.

The Expert Committee noted the latest update of the database and encouraged the WHO Secretariat to continue updating it on an annual basis.

4.3 Guidelines and guidance texts adopted by the ECSP

ECSP members were updated by correspondence on the consolidated list of all guidelines and guidance texts adopted by the ECSP. A full and updated list of WHO norms and standards for medicines, quality assurance and regulatory guidance adopted by the Expert Committee included more than 130 texts. It was categorized into seven broad topic areas: development, distribution, inspections, production, quality control, regulatory standards, and prequalification.

The Expert Committee noted the report and agreed that the list should be updated annually and integrated into the ECSP report, preferably in alphabetical order (Annex 1). The experts encouraged the WHO Secretariat to continue exploring ways of publishing those guidelines individually to support easier access to them.

5. Quality control: national laboratories

5.1 External Quality Assurance Assessment Scheme

ECSP members were updated by correspondence on ongoing activities in the External Quality Assurance Assessment Scheme (EQAAS), which offered a platform for pharmaceutical quality control laboratories (PQCLs) to measure their performance through a confidential system of blind testing.

Organized by WHO with the assistance of the European Directorate for the Quality of Medicines and HealthCare (EDQM), EQAAS had been evaluating the technical performance of PQCLs since 2000. EQAAS was a proficiency testing scheme that served to demonstrate the reliability of laboratory analytical results by objective means; independently verify a laboratory's competence; establish mutual confidence with collaborating networks; and support continuous improvement in performance.

EQAAS was run according to international standards for proficiency testing set by the International Organization for Standardization and the International Electrotechnical Commission. Since the scheme started, laboratories from across WHO's six regions had participated in more than 1200 studies, involving 36 different tests.

5.1.1 Final report on EQAAS phase 10

There had been 44 participants in phase 10 of EQAAS, from across all WHO regions. Those had to complete three procedures, using zinc sulfate tablets and zinc salts (acetate and sulfate) as the common test samples. The tests had been well designed and the results obtained had been subjected to sound statistical evaluation.

- Test 1: determine in triplicate the percentage content of zinc using the complexometric titration method of *The International Pharmacopoeia*. In total, 34 out of 42 laboratories had reported satisfactory results, with four laboratories reporting doubtful results and three reporting unacceptable results. One laboratory had reported an incorrect mean value and so had not been subjected to performance evaluation.
- Test 2: confirm the disintegration of paediatric zinc tablets within 60 seconds according to the general disintegration test method of *The International Pharmacopoeia*. Twenty-one laboratories (48%) had reported satisfactory results. A follow-up survey of laboratories suggested that the high failure rate could potentially be the result of incorrect operational procedures and interpretation errors; survey findings would be published in *WHO Drug Information*.

- Test 3: carry out the sulfates identification test of *The International Pharmacopoeia* on two blinded zinc salt samples. In total, 35 out of 44 laboratories had reported satisfactory results.

Laboratories that had produced acceptable results were encouraged to use EQAAS as a stimulus for continuous improvement. Laboratories that had failed the tests were recommended to consider potential sources of error.

5.1.2 Update on EQAAS phase 11

The procedures and organizational aspects of EQAAS phase 11 remained under discussion.

The Expert Committee noted the update and encouraged WHO to continue EQAAS in support of national and regional PQCLs, including continuing the post-assessment assistance programme. The Expert Committee expressed concern about the high failure rate in disintegration testing (test 2) and requested that the outcome of the survey, and any follow-up action taken, also be communicated at the next ECSP. Expert Committee members noted a potential need to discuss the costing structure for EQAAS, which had been raised as a concern by some countries. It asked for an update on that issue at its next meeting.

6. Quality control: specifications and tests

6.1 *The International Pharmacopoeia*

Dr Herbert Schmidt, Technical Officer, Norms and Standards for Pharmaceuticals, presented an overview of *The International Pharmacopoeia (1)*, which was a collection of quality specifications for pharmaceutical substances and dosage forms, together with supporting general methods of analysis. That collection, which was free to use, served as source material for reference or adaptation by any WHO Member State wishing to establish pharmaceutical requirements. It provided the means for national quality control laboratories, procurers and public pharmacies to independently check the quality of a medicine at any time during its shelf-life.

The International Pharmacopoeia focused on providing standards for essential medicines that met global public health priorities. As such, it was primarily based on medicines that were included in the EML, were the subject of invitations to submit an expression of interest for prequalification, or were recommended by WHO or United Nations specific disease programmes. *The International Pharmacopoeia* was aligned with other major pharmacopoeias as far as possible, it was developed in collaboration with laboratories and expert groups and in consultation with stakeholders. The monograph development process, which was governed by publicly available rules and procedures, was designed to ensure complete transparency and to enable the participation of all interested parties. Before being included in the collection, every monograph must be formally adopted by the ECSPP.

First published in the 1950s, *The International Pharmacopoeia* would shortly be available in its 11th edition (2022) as a digital library published on the WHO website. The 11th edition would contain all new and revised texts that had been agreed by the fifty-fifth and fifty-sixth ECSPPs in 2020 and 2022. The 11th edition was being made possible with the strong support of ECSPP experts, EDQM, WHO collaborating centres, collaborating laboratories and organizations, the ICRS Board, and many WHO colleagues.

The Expert Committee noted the update.

6.1.1 **Workplan 2022–2023**

Professor Kaouther Zribi, Technical Adviser, presented a proposed workplan for *The International Pharmacopoeia* for 2022–2023. The workplan included a listing of 183 medicines proposed for development under three levels of priority: 43 to be developed with priority A (medicines mentioned in the EML and expressions of interest), 43 with priority B (medicines mentioned only in expressions of interest), and 97 with priority C (medicines mentioned only in the EML).

All priority monographs had been selected based on a survey to identify medicines that were listed in the EML or that had been subject to an invitation to submit an expression of interest for prequalification of medicines.

One fifth (20%) of the proposed priority medicines were antiviral medicines, 18% were antituberculosis medicines and 8% were immunomodulators and antineoplastic medicines (Fig. 1). They included medicines that were relevant to various WHO areas of work, including specific disease programmes and the prequalification of medicines programme. They also included medicines relevant to the ongoing COVID-19 pandemic, such as the antiviral medicines molnupiravir capsules and nirmatrelvir tablets.

Fig. 1
Types of medicines proposed for priority development

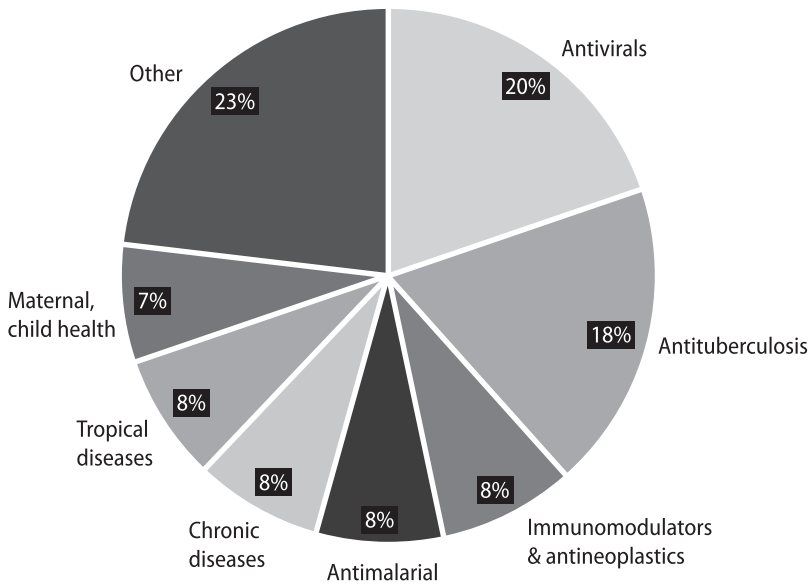

In practice, the monographs from the priority list that actually get developed would depend largely on the resources available and the extent of manufacturers' support.

The Expert Committee adopted the workplan 2022–2023 as presented.

6.2 General chapters

6.2.1 Chromatography

The ECSPP was asked to consider a new general chapter on chromatography in *The International Pharmacopoeia*, which comprised the internationally harmonized text developed by the Pharmacopoeial Discussion Group. The new chapter would replace the existing chapters on thin-layer chromatography, high-performance liquid chromatography and gas chromatography.

The new chapter had been drafted in December 2021 and put out for public consultation in February and March 2022.

The ECSPP discussed the new chapter and feedback received during the public consultation, including the question of whether to keep the existing chapters on paper chromatography and column chromatography, given that there was no coverage of those chromatographic techniques in the Pharmacopoeial Discussion Group text. It agreed to keep both chapters and recommended only a minor change to one of the sections of the new chapter to maintain alignment with the Pharmacopoeial Discussion Group text.

The Expert Committee adopted the new chapter to replace three of the five existing chapters on chromatographic techniques, subject to the minor amendment discussed.

6.3 Specifications and draft monographs for medicines, including paediatrics and candidate medicines for COVID-19

6.3.1 COVID-19 therapeutics

Medicinal oxygen

The ECSPP was asked to consider a revision to the existing monograph on oxygen. The revision clarified that in considering options for increasing the supply of medicinal oxygen to treat COVID-19 and other diseases, Member States could safely apply oxygen generated by liquefaction of air in a large-scale industrial process or by pressure or vacuum swing adsorption (PSA or VSA), often at hospitals, whereby ambient air was conducted over molecular sieves or other materials that adsorb certain components of the air, in particular nitrogen and carbon dioxide, and so enrich the oxygen. The first process led to oxygen 99.5%, the latter to oxygen 93%.

The newly revised monograph defined quality requirements for these two oxygen products and defined medicinal oxygen as oxygen 93% or oxygen 99.5%. Other products with different oxygen concentrations or produced using different production methods might also be considered as medicinal oxygen if they were approved by the appropriate national or regional authority. Depending on the clinical medicinal necessity, and in accordance with clinical guidelines, medicinal oxygen was used in the undiluted form as mixtures of oxygen 93%,

oxygen 99.5% or other oxygen products; or as mixtures with ambient or compressed air of a suitable quality or with other medicines.

The revision had been drafted in December 2020 following discussions within WHO. Since then, it had been through two public consultations, with comments received discussed by experts and included where appropriate. Most recently, the revised monograph had been discussed at the consultation on screening technologies, laboratory tools and pharmacopoeial specifications for medicines in September 2021, as well as internally and with stakeholders.

The Expert Committee noted that the monograph had been introduced to promote universal and equitable access to medicinal oxygen. It noted that a concern raised by a stakeholder during the public consultations had been satisfactorily addressed in the “additional information” section of the version presented to the ECSPP for adoption. ECSPP members discussed the comments received and the latest draft of the monograph.

The Expert Committee adopted the monograph.

Molnupiravir

Molnupiravir capsules

Draft monographs on molnupiravir and molnupiravir capsules had been proposed for inclusion in *The International Pharmacopoeia*. As the first public standards on molnupiravir, those monographs were expected to play an important role in ensuring access to safe, effective and quality-assured molnupiravir-containing medicines.

Both monographs had been drafted in December 2021 and sent for public consultation in January 2022. Laboratory investigations to verify analytical provisions were still needed for both monographs, after which a revised draft would be sent for further public consultation followed by a review and discussion of the comments received and the results of the laboratory investigations by a group of experts.

The ECSPP discussed elements of both draft monographs, including the proposed limits for related substances. The Expert Committee also discussed some of the challenges posed by hydroxypropylmethylcellulose (HPMC) capsule shells (so-called vegetarian capsule shells) and suggested that it would be useful to consider revising the general capsules chapter to include a paragraph on those. Such a revision should set out the aspects that should be considered during product development to address potential issues with dissolution and variability.

The Expert Committee adopted the monographs, subject to finalization by a group of experts following a public consultation. If major comments were received during the consultation, or if any major issues arose from the laboratory investigations, the monographs should be resubmitted to the next ECSPP.

6.3.2 Medicines for maternal, newborn, child and adolescent health

Norethisterone enantate

Norethisterone enantate injection

Based on a submission from a manufacturer and on laboratory investigations, the ECSPP was asked to consider revising the existing monograph on norethisterone enantate, and to adopt a new monograph on norethisterone enantate injection.

The draft revisions and new text had first been proposed in June 2017 by a collaborating laboratory. Subsequently, they were sent for public consultation (July–September 2017), presented at three ECSPP meetings (2017, 2019 and 2020), further revised, and discussed at four annual informal consultations on screening technologies and pharmacopoeial specifications for medicines (2018–2021). A fifth draft of revisions included consideration of the latest rounds of discussion and laboratory investigations.

The ECSPP provided feedback on the current versions of both monographs, proposing some amendments to the identity tests in the monograph on norethisterone enantate.

The Expert Committee adopted both monographs, subject to the minor amendments discussed.

Ulipristal acetate

Ulipristal acetate tablets

Draft monographs on ulipristal acetate and ulipristal acetate tablets were proposed for inclusion in *The International Pharmacopoeia*. The methods and specifications described in the monographs were based on a submission from a manufacturer in January 2021 and on laboratory investigations from February to June 2021.

Following those investigations, the monographs had been sent for public consultation (July–August 2021). The ECSPP discussed comments received during the public consultation for both monographs as well as the results of the laboratory investigations. It proposed some amendments to the identity tests and made suggestions for editorial revisions.

The Expert Committee adopted both monographs, subject to the minor amendments discussed.

6.3.3 Antimalarial medicines

Artemimol

The ECSPP was asked to consider revising the existing monograph on artemimol. In particular, the proposed revision was to delete one of the two alternative assay methods (the UV assay – method B) from the monograph because that method had been found to lack sufficient precision during work to establish the artemimol ICRS.

The proposed revision had been scheduled for public consultation in mid-2022, after which any comments received would be discussed by a group of experts in a follow-up meeting.

The ECSPP discussed the proposed revision, agreeing that the UV assay method lacked sufficient precision and should be deleted from the monograph.

The Expert Committee adopted the revised monograph, subject to finalization by a group of experts following public consultation. If major comments were received during the consultation, the monographs should be resubmitted to the next ECSPP.

6.3.4 Antituberculosis medicines

Isoniazid

Isoniazid tablets

The ECSPP was asked to consider revising the existing monographs on isoniazid and isoniazid tablets.

The proposed revisions had been drafted in June 2021 and had been subject to laboratory investigations from June 2021 to March 2022. Both monographs were due to go out for public consultation after the meeting of the Expert Committee.

The ECSPP discussed both monographs, including the results of the laboratory investigations, and suggested seeking comments on the suitability of an identity test using the melting point.

The Expert Committee adopted the draft monographs, subject to finalization by a group of experts following a public consultation. If major comments were received during the consultation, the monographs should be resubmitted to the next ECSPP.

Linezolid

Linezolid tablets

Draft monographs on linezolid and linezolid tablets were proposed for inclusion in *The International Pharmacopoeia*. The methods and specifications articulated in the monograph were based on submissions from manufacturers and information found in other pharmacopoeias and in the scientific literature.

The proposed monographs had been drafted in August 2019 and discussed at the fifty-fourth ECSPP later that year. They had been discussed at two informal consultations on screening technologies and pharmacopoeial specifications for medicines (in 2020 and 2021). They had also been subject to public consultation, in April–May 2020, and subsequently revised based on feedback. A second round of public consultation was planned in June–July 2022.

The ECSPP discussed various aspects of the draft monographs, including limits for related substances. It suggested revising the limits for unspecified impurities considering the maximum daily dose of linezolid.

The Expert Committee adopted the draft monographs, subject to finalization by a group of experts following a public consultation. If major comments were received during the consultation, the monograph should be resubmitted to the next ECSPP.

6.3.5 Antiviral medicines, including antiretrovirals

Lamivudine

Lamivudine oral solution

The ECSPP was asked to consider revising the existing monographs on lamivudine and lamivudine oral solution. In particular, the proposals for the monograph on lamivudine suggested revising the test for related substances and adding an alternative assay by high-performance liquid chromatography; they also suggested adding a test for lamivudine enantiomer.

The proposed revisions had been discussed at the May 2019 informal consultation on screening technologies and pharmacopoeial specifications for medicines and then sent for public consultation. The draft had then been revised and discussed at the next informal consultation on screening technologies and pharmacopoeial specifications for medicines in April 2020. Laboratory investigations to verify the analytical provisions had been held in the last quarter of 2021.

The ECSPP discussed the latest drafts of both monographs, as well as the results of laboratory investigations. It suggested amendments to both monographs and proposed that approaches to designing identity tests be summarized in a policy to improve consistency in how appropriate identity test combinations were chosen for new monographs in *The International Pharmacopoeia*.

The Expert Committee adopted the revised monographs, subject to the amendments discussed. It further tasked the WHO Secretariat with compiling approaches to designing identity tests in a policy for discussion at the next informal consultation, with an update to be provided to the next ECSPP.

Dolutegravir dispersible tablets

The ECSPP was asked to consider including a new monograph on dolutegravir dispersible tablets in *The International Pharmacopoeia*. The proposed monograph had been drafted in June 2021 and sent for public consultation in July–September 2021.

The monograph was based on the monograph for dolutegravir tablets adopted by the fifty-fifth ECSPP with changes in the definition and the addition of a test for disintegration.

The ECSPP discussed the proposed monograph and comments received during the public consultation. It suggested an editorial change to the related substances test. It further suggested adding a test for fineness of dispersion.

The Expert Committee adopted the new monograph, subject to the amendments discussed.

Dolutegravir, lamivudine and tenofovir disoproxil tablets

The ECSPP was asked to consider including a new monograph on dolutegravir, lamivudine and tenofovir disoproxil tablets in *The International Pharmacopoeia*. The proposed monograph would be the first public standard for that medicine and as such was expected to play an important role in ensuring universal and equitable access to first-line treatment of HIV/AIDS.

The proposed text for the new monograph had first been drafted in July 2019, after which it had been sent for public consultation before being presented to the fifty-fourth ECSPP. Feedback from the Expert Committee had informed revisions to the draft monograph, which had then been discussed at two annual informal consultations on screening technologies and pharmacopoeial specifications for medicines (in 2020 and 2021).

The ECSPP discussed the draft monograph, noting that the limits for some impurities were different in other monographs for tenofovir disoproxil fumarate finished products. It proposed some amendments to related substance tests.

The Expert Committee adopted the revised monograph, subject to the minor amendments discussed. It further tasked the WHO Secretariat with reviewing other finished dosage form monographs containing tenofovir disoproxil fumarate to harmonize the requirements for related substances.

Tenofovir disoproxil fumarate

The ECSPP was asked to consider revisions to the existing monograph on tenofovir disoproxil fumarate, to add a test for the enantiomer of tenofovir disoproxil, revise the test for related substances and make some editorial changes.

A first draft of the revised monograph had been prepared in July 2019 and sent for public consultation. That draft had been presented to the fifty-fourth ECSPP in October 2019 and discussed at the informal consultation on screening technologies and pharmacopoeial specifications for medicines in May 2021. Those had informed a second draft that had again been sent out for public consultation (February–April 2022) before being submitted to the ECSPP for possible adoption.

ECSPP members discussed the latest draft of the monograph, including tests for impurity limits, but no further amendments were suggested.

The Expert Committee adopted the revised monograph.

6.3.6 Other medicines

Radiopharmaceuticals

ECSPP members were updated by correspondence on texts on radiopharmaceuticals in *The International Pharmacopoeia*, which currently included a general monograph and 27 specific monographs and texts on methods of analysis, safety considerations and other guidance on preparing and testing radiopharmaceuticals.

In 2015, the International Atomic Energy Agency (IAEA) had updated several monographs, which had then been presented to the ECSPP in 2017. Since then, the monographs had been revised by a senior expert and discussed with a group of experts in 2019. The revised general monograph was intended for publication in the next edition of *The International Pharmacopoeia*.

Technical issues remained for individual monographs, specifically with regard to:

- aligning the requirements of specific monographs with those of general chapters;
- defining the quality of reagents used;
- drawing chemical structures to fit WHO guidelines;
- optimizing the consistency of provisions.

Those issues would be resolved through collaboration with the IAEA, after which the monographs would be recirculated for consultation. To that end the IAEA had already advised suppression of the monograph on Y-90 silicate injection, as the product was no longer in use; a document on that matter would be circulated for comment and submitted to the Expert Committee for consideration at its next meeting.

The Expert Committee noted the update.

6.4 Update on the virtual consultations on screening technologies, laboratory tools and pharmacopoeial specifications

ECSPP members were updated by correspondence on the two consultations on screening technologies, laboratory tools and pharmacopoeial specifications held since the fifty-fifth ECSPP. The consultations were normally held annually in person, but in 2021 had taken place virtually, in May and September.

At the consultations, 27 experts from across the world had been updated on 28 monographs and general texts under development for *The International Pharmacopoeia*. Results of phase 10 of EQAAS had been presented, as well as the first draft revision of the WHO guideline on good laboratory practices for pharmaceutical quality control laboratories. The experts discussed all draft proposals and other documents and provided guidance on future work.

The Expert Committee noted the update.

7. Quality control: international reference materials

7.1 Update on International Chemical Reference Substances

Expert committee members were updated by correspondence on activities related to International Chemical Reference Substances (ICRS) by the dedicated ECSPP subgroup on ICRS.

ICRS were used to identify and determine the purity or assay of pharmaceutical substances and preparations, or to verify the performance of test methods. The EDQM had been the custodial centre for ICRS since 2010 and as such was responsible for establishing, storing and distributing ICRS.

Since the previous meeting of the ECSPP in October 2020, the ICRS Board had released the following chemical reference substances, established by the EDQM, for use according to the provisions of *The International Pharmacopoeia*:

- ivermectin ICRS, batch 1
- alpha-artemether ICRS, batch 2
- ciprofloxacin impurity A ICRS, batch 1
- levamisole hydrochloride ICRS, batch 1
- ciprofloxacin hydrochloride ICRS, batch 2
- daclatasvir for system suitability ICRS, batch 1
- daclatasvir for peak identification ICRS, batch 1
- daclatasvir dihydrochloride ICRS, batch 1
- amodiaquine hydrochloride ICRS, batch 2
- dexamethasone sodium phosphate for assay ICRS, batch 1
- carbamazepine ICRS, batch 2.

The ICRS update highlighted some of the EDQM's key achievements in relation to ICRS in 2021, which included completing six ICRS establishment reports for WHO. The EDQM had released eight batches of ICRS for distribution, and had also monitored 17 standards for continuous fitness for purpose, with no significant findings on quality to report.

The WHO Secretariat expressed its gratitude to:

- the EDQM for its work in establishing, storing and distributing ICRS and for providing guidance and support to primary standards;
- the ICRS Board for reviewing the establishment reports and releasing the ICRS;
- the collaborating laboratories for participating in collaborative trials to determine the assigned content.

The Expert Committee noted the report and confirmed the release of all the ICRS listed above.

8. Quality assurance: good manufacturing practices and inspection

8.1 Good manufacturing practices for sterile pharmaceutical products

Dr Adriaan J. Van Zyl, ECSPP member, updated the Expert Committee on progress in revising good manufacturing practices (GMP) for sterile pharmaceutical products. That work represented a collaborative effort between the European Medicines Agency, the Pharmaceutical Inspection Co-operation Scheme (PIC/S) and WHO to try and harmonize standards across the world. Establishing a common language was expected to benefit authorities and manufacturers, save resources and ultimately improve patients' access to quality medicines.

First drafted at the end of 2017, the revised guideline had been through several rounds of internal discussion, two rounds of public consultation through WHO, consideration at previous ECSPP meetings, and subsequent revision. In 2021, the joint drafting group had informed WHO that the document (version 14) was ready for submission for adoption. WHO had held an internal consultation on that version and had sent comments and recommendations for editorial changes to the drafting group. Those had not been considered because they were deemed to be too late. The final version (version 15) submitted for adoption by the European Commission included some editorial changes proposed by Australia.

The Expert Committee discussed the latest version of the guideline (version 15), which was expected to be adopted by the European Commission and PIC/S participating authorities. It noted that that version excluded some technical revisions proposed by the WHO Prequalification Team for Inspection Services (PQT/INS) as well as various editorial changes suggested by WHO, including references to WHO guidelines and bringing it into line with WHO editorial style. Experts acknowledged the value of harmonized guidelines but stressed the need for any guideline adopted by the ECSPP to be consistent with other WHO standards.

Other points of discussion focused on the timing for publishing a revised guideline (which should, as far as possible, align with European Commission and PIC/S publication schedules) and on transition periods. ECSPP members were informed that the European Commission would set time frames for transitioning to the requirements in the new guideline. The Expert Committee noted that WHO did not usually set transition periods in its guidelines; it was the responsibility of Member States to decide what time frame was appropriate for their own country context.

The Expert Committee adopted the WHO good manufacturing practices for sterile pharmaceutical products, based on the harmonized text, subject to the inclusion of the editorial changes and technical revisions proposed by WHO (see Annex 2).

8.2 Good manufacturing practices for investigational radiopharmaceutical products

Dr Aruna Korde, Radiopharmaceutical Scientist, International Atomic Energy Agency (IAEA), updated ECSP members on progress in developing GMP guidelines for radiopharmaceuticals by the IAEA and WHO. In 2019, the ECSP had adopted the *IAEA/WHO guideline on good manufacturing practices for radiopharmaceuticals (4)*. That guideline provided a general overview of the minimum GMP requirements for radiopharmaceutical products and represented just one part of ongoing IAEA/WHO efforts to update broader guidance on GMP for radiopharmaceuticals, as had been recommended by IAEA experts in early 2018. Production procedures for radiopharmaceuticals varied depending on the complexity of the product as well as the radiopharmacy setting and product distribution criteria. For that reason, separate guidance was envisaged, especially for GMP for investigational radiopharmaceuticals and for cold kits used in radiopharmaceutical preparations.

In June 2020, at a virtual meeting of experts, IAEA and WHO had decided to focus first on developing a guideline on GMP for radiopharmaceuticals for investigational use.

A first working document had been drafted in late 2020 and sent to a group of experts for comment before being posted for public consultation in March 2021. Comments received had been shared with and discussed by an IAEA expert working group and a revised draft had been prepared. That had been sent for a second round of public consultation from July to September 2021. The latest draft presented to the ECSP had been discussed at a virtual meeting with the IAEA expert working group.

The new guideline had been developed in alignment with the *Good manufacturing practices; supplementary guidelines for the manufacture of investigational pharmaceutical products for clinical trials in humans (5)* (see section 8.6). It emphasized the need to ensure that investigational radiopharmaceuticals were produced and managed in accordance with an effective quality management system and GMP. The new guideline covered various topics, including quality management, control and validation, as well as giving detailed guidance on documentation, equipment, materials and production, among other things.

The Expert Committee discussed the requirements of the new guideline, noting that there were some necessary differences compared with the WHO

GMP on investigational products because, for example, of differences in recall procedures or sample storage requirements for radiopharmaceuticals compared with conventional pharmaceuticals. It further noted that the new guideline for investigational radiopharmaceuticals reflected minimum standards that all countries, including low- and middle-income countries, should be able to meet.

The Expert Committee adopted the IAEA/WHO good manufacturing practices for investigational radiopharmaceutical products (see Annex 3).

8.3 Guidelines on technology transfer in pharmaceutical manufacturing

Dr Steve Estevão Cordeiro, Technical Officer, Norms and Standards for Pharmaceuticals, and Dr Adriaan J. Van Zyl presented a revised draft of the previously entitled *WHO guidelines on transfer of technology in pharmaceutical manufacturing* (6). There had been several regulatory changes since publication of the original guidelines in 2011. Following proposals made during the 2020 consultation on good practices for health products manufacture and inspection, the fifty-fifth ECSPP had recommended that WHO consider updating the guidelines on technology transfer, especially to support local production in view of the COVID-19 pandemic.

Technology transfer was an integral part of product life cycle management and was subject to regulatory expectations. It required a planned, risk-based approach. The newly revised guidelines covered technology transfer, including transfer from research and development to production sites and between production sites. The principles described in the guidelines applied to pharmaceutical products and could also apply to other products, including vaccines and other biological products. The guidelines covered various aspects of risk-based technology transfer, including due diligence and gap analysis; organization and management; quality risk management; documentation; premises; equipment and instruments; and qualification and validation. They also provided specific guidance for sending and receiving units during different phases of a technology transfer project, from initial discussion to final review.

A first draft working document had been developed in late 2020 and sent to a group of experts for comment before being posted for public consultation in December 2020. A revised draft had been prepared and discussed at a virtual meeting with experts in March 2021. A second round of public consultation had been held in April and May 2021.

In response to that feedback, various revisions had been made to refine and clarify the guideline. The revised draft had been discussed at the virtual consultation on good practices for health products manufacture and inspection in June 2021 and revised once more before being presented to the ECSPP.

The ECSPP had reviewed the latest draft document and discussed various issues, particularly the scope of the document, which it agreed should not include vaccines and other biological products. It emphasized that technology transfer was a highly important issue for vaccines and other biological products but agreed that while the general principles still applied, there might be specificities in technology transfer for vaccines and other biological products that demanded separate, complementary guidelines.

Other points of discussion included analytical procedure validation, regulatory requirements and documentation required for technology transfer. The Expert Committee requested an amendment to clarify the need for compliance with regulatory requirements where changes arising from technology transfer might impact product quality and efficacy.

The Expert Committee adopted the WHO guidelines on technology transfer in pharmaceutical manufacturing (Annex 4), subject to the changes discussed. It further encouraged the ECBS to consider developing separate, complementary guidelines that addressed the specificities of technology transfer for vaccines and other biological products.

8.4 Good manufacturing practices for medicinal gases

Dr Estevão Cordeiro and Dr Adriaan J. Van Zyl presented a new guideline *WHO good manufacturing practices for medicinal gases*, which had been developed following recommendations by several WHO teams dealing with oxygen supply and inspection of production sites for medicinal gases during the COVID-19 pandemic.

While there were other published guidelines, such as those of the European Union and the PIC/S, the COVID-19 pandemic had resulted in an urgent and increased need for more widely applicable standards that could ensure the rational use of oxygen and medicinal gases in all WHO Member States. The new guideline, which was harmonized with other published guidelines, covered various aspects of production, control, storage and distribution, including quality management, personnel, documentation, recalls and returns, self-inspection, premises and equipment, qualification and validation, and continuous improvement.

A first draft working document had been developed in early 2021 and sent to a group of experts for comment before being posted for public consultation in February 2021. A revised draft had been prepared and discussed at the virtual consultation on good practices for health products manufacture and inspection in June 2021. Key points of discussion during the consultation had focused on the use of terminology, specifically “medical gases” versus “medicinal gases” and “technical oxygen” versus “industrial oxygen”. A second round of public consultation had been held in July and August 2021 and the

feedback from that had been considered for the latest draft document presented to the ECSPP.

The ECSPP acknowledged the usefulness of the document, noting that it was the first WHO guideline on this topic. It discussed the latest changes and took note of the clarification provided on the section relating to the mixture of gases.

The Expert Committee adopted the WHO good manufacturing practices for medicinal gases (Annex 5).

8.5 Good practices for research and development facilities

Dr Estevão Cordeiro and Dr Adriaan J. Van Zyl presented a new guideline *WHO good practices for research and development facilities*, which had been developed following a recommendation by WHO PQT/INS. With the ever-growing demand for new health products, including COVID-19 therapies, there was a need to ensure that selected aspects of research and development were appropriately controlled and documented. The new guideline provided guidance on good practices for manufacturing developmental batches, pilot batches and stability testing where data were submitted in applications for marketing authorization in Member States and WHO prequalification.

The guideline covered various topics, such as risk management, inspections, process design and quality control, stability studies, and analytical procedure development.

A first draft working document had been developed in late 2020 and sent to a small group of experts for comment before being posted for public consultation in November 2020. A revised draft document had been prepared and discussed at the virtual consultation on good practices for health products manufacture and inspection in June 2021. A second round of public consultation had been held in July and August 2021 and the feedback from that had resulted in a number of changes to the document. These had been included in the latest draft presented to the ECSPP.

The ECSPP discussed the latest version of the document, noting that it had been designed to provide broad guidance on good practices rather than being a restrictive, enforceable GMP guideline. It also noted that the scope focused specifically on areas of activities in research and development facilities where data were generated to be used for registration purposes. It did not cover the manufacture of commercial batches of products as that fell within the scope of GMP. ECSPP members proposed several changes to improve clarity of the text. They also suggested removing all references to cross-contamination at the research and development stage, as those products were not intended for human use.

The ECSPP acknowledged the importance of the new guidance and thanked all those involved in preparing, reviewing and revising it.

The Expert Committee adopted the WHO good practices for research and development facilities of pharmaceutical products (Annex 6), with the inclusion of some minor changes.

8.6 Good manufacturing practices for investigational products

Dr Estevão Cordeiro and Dr Adriaan J. Van Zyl updated ECSPP members on the revision of the previously entitled *WHO good manufacturing practices: supplementary guidelines for the manufacture of investigational pharmaceutical products for clinical trials in humans* (5), as requested by the fifty-fifth ECSPP. The original guideline had been published in 1996 and the ECSPP request was made following an appeal for revision from WHO PQT/INS. The revised guideline aimed to bring the WHO guideline in line with current expectations and trends in good practices, including those expressed in related international guidelines.

It emphasized the need to ensure that investigational products were manufactured, packaged, tested, handled, stored and distributed in accordance with an effective quality management system and good manufacturing practices to minimize risks and ensure the safety of subjects participating in clinical trials. The revised guideline covered various topics, including quality management, control and validation, as well as giving detailed guidance on documentation, equipment, materials, and production, among other things.

A first draft working document had been developed in late 2020 and sent to a small group of experts for comment before being posted for public consultation in November 2020. A revised draft had been prepared and discussed at the virtual consultation on good practices for health products manufacture and inspection in June 2021. A second round of public consultation had been held in July and August 2021 and the feedback from that had informed several revisions to refine and clarify the guidance. Those had been included in the latest draft presented to the ECSPP.

The ECSPP reviewed the latest changes, noting that those included revisions to improve harmonization with guidelines recently published by the European Union. It made some suggestions for revisions to clarify the scope of the document, which, as defined in the glossary, covered investigational pharmaceutical products for human use.

The Expert Committee adopted the WHO good manufacturing practices for investigational products (Annex 7), with the inclusion of some minor changes.

8.7 Recommendations from the virtual consultation on good practices for health products manufacture and inspection

ECSP members were updated by correspondence on the annual consultations on good practices for health products manufacture and inspection, which had taken place in July 2021.

During those meetings, a small group of experts had discussed a number of topics, including GMP for sterile pharmaceutical products (see section 8.1), GMP for radiopharmaceuticals (see section 8.2), guidelines on technology transfer in pharmaceutical manufacturing (see section 8.3), GMP for medicinal gases (see section 8.4), good practices for research and development facilities (see section 8.5), GMP for investigational products (see section 8.6), and guidance on the shelf-life for emergency health kits (see section 9.1).

The group had also proposed the development of a new guideline addressing environmental protection from the pharmaceutical manufacturing of antimicrobials. That document would fill gaps in the current ISO 14001:2015 standard on environmental management systems and direct responsible national agencies in their duties on waste management of pharmaceuticals. Development of the new guideline would be in collaboration with the United Nations Environment Programme (UNEP).

The Expert Committee noted the update. It agreed to support the development of a guideline on management of waste and wastewater from pharmaceutical manufacturing, in collaboration with UNEP and with a focus on antimicrobials, recognizing that environmental protection was not always in the scope of GMP inspectorates.

9. Quality assurance: distribution and supply chain

9.1 Setting remaining shelf-life for supply and procurement of emergency health kits

Ms Sophie Laroche, Quality Officer, WHO Procurement and Supply Services, and Ms Danielle Jurman, Humanitarian Supplies Analyst, United Nations Population Fund (UNFPA), updated ECSPP members on progress in amending the *Points to consider for setting the remaining shelf-life of medical products upon delivery guidance* (7) to include emergency health kits as an additional example, as recommended by the fifty-fifth ECSPP. The need to include health kits for use in emergencies in the guidance had been raised during the 2019 public consultation on the guidance and, since publication of the guideline, a group of humanitarian stakeholders had renewed the call for an amendment.

A draft amendment, in the form of an appendix, had been developed by a working group of the Interagency Pharmaceutical Coordination Group. It stated that emergency health kits required the same risk-based analysis as other medical products, but it emphasized that the complexities of emergency health kits and the contexts in which they were used demanded specific considerations in their use. That had formed the basis for the newly drafted appendix, which included a list of examples of remaining shelf-life for emergency health kits at different points of delivery, including emergency health kits for use in acute emergency response and those for use in prepositioning in preparedness or post-acute emergency response.

Since the previous ECSPP meeting, the draft amendment had been sent out for two public consultations and refined in response to feedback received.

The ECSPP reviewed the new appendix and thanked all those involved in drafting and reviewing it.

The Expert Committee adopted the revised Points to consider for setting the remaining shelf-life of medical products upon delivery guidance (Annex 8).

9.2 WHO/UNFPA guidance on natural rubber latex condom stability studies

Ms Linda Serwaa, Technical Specialist, United Nations Population Fund (UNFPA), and Dr William Potter, Consultant to UNFPA, summarized the WHO/UNFPA collaboration to update the existing prequalification guidance for contraceptive devices and condoms, which had originally been published in 2008 and which no longer reflected current understanding and evidence in the field.

Several updated guidelines for contraceptive devices and condoms had already been adopted by the ECSPP (on prequalification programme guidance, technical specifications for male latex condoms, specifications for plain lubricants,

testing male latex condoms, storage and shipping recommendations, and post-market surveillance).

Draft new guidance for natural rubber latex male condoms stability studies was presented to the ECSP for adoption. The draft document included background information on the factors that could affect condom stability and improved guidance relating to condom shelf-life and conducting stability studies. It was intended to help manufacturers formulate and manufacture condoms that were stable and could meet the claimed shelf-life specification when stored in adverse climatic conditions.

The document had been developed in early 2019, and had incorporated comments received from the UNFPA prequalification pool of technical experts and from manufacturers in September 2019 and February 2020 respectively. Those had been reviewed and new drafts prepared for public consultation in May 2021. The comments received had been used to prepare a revised draft for discussion at the virtual consultation on good practices for health products manufacture and inspection in June 2021. A second round of public consultation had been held in August 2021, with no comments received, and the latest draft was presented to the ECSP.

The ECSP discussed various aspects of the guidance. It noted that the monitoring of protein levels to ensure they remained within acceptable limits (to avoid latex allergies) was not covered in the document, but it was covered in the main specification, as referenced in the new guidance.

The Expert Committee adopted the WHO/UNFPA guidance on natural rubber male latex condom stability studies (Annex 9).

9.3 WHO/UNFPA technical specification for TCu380A intrauterine device

Ms Linda Serwaa, Technical Specialist, UNFPA, and Dr William Potter, Consultant to UNFPA, updated ECSP members on progress in revising the prequalification guidance for the TCu380A intrauterine device, which had been undertaken as part of the broader WHO/UNFPA collaboration to update the existing prequalification guidance for contraceptive devices and condoms (see sections 9.2 and 9.3).

Clinical studies had shown that the TCu380A intrauterine device was safe and effective. Its technical specification had last been updated in 2016 to include improved specifications for raw materials and components, updated storage requirements and time limits, and improved guidance for stability studies, among other things. The latest revisions to the guidance focused on removing reference to specific manufacturers and trade names for raw materials. In addition, the revisions proposed improvements to test methods and minor changes to specification requirements based on feedback from manufacturers.

The latest update had begun with revision of the document in the second half of 2018, followed by its restructure in 2019. In May 2021 it had been put out for public consultation. A revised draft had been prepared for discussion at the virtual consultation on good practices for health products manufacture and inspection in June 2021. A second round of public consultation had been held in August and September 2021 and the feedback had informed the latest draft presented to the ECSP.

The ECSP reviewed the document, noting that most of the changes prompted by the second round of public consultation had been editorial.

The Expert Committee adopted the WHO/UNFPA technical specification for TCu380A intrauterine device (Annex 10).

10. Regulatory guidance and model schemes

10.1 WHO Biowaiver List: proposal to waive in vivo bioequivalence requirements for medicines included in the EML

Dr Estevão Cordeiro and Technical Adviser Professor Maria del Val Bermejo Sanz gave an overview of the WHO Biowaiver Project and presented the project's work over the previous year. The project was WHO's solubility classification exercise and provided an important tool for national regulatory authorities and pharmaceutical manufacturing companies by suggesting medical products that were eligible for a waiver from in vivo bioequivalence studies.

The project used sound methods to determine the equilibrium solubility profile of medicines listed in the EML, as detailed in the WHO *Protocol to conduct equilibrium solubility experiments for the purpose of Biopharmaceutics Classification System-based classification of active pharmaceutical ingredients for biowaiver* (8). Started in 2018, the WHO Biowaiver Project was organized into annual study cycles. Its results were incorporated each year in the WHO Biowaiver List, which was a living document that was published as an annex to each ECSPP report.

In 2021, as part of cycle IV of the WHO Biowaiver Project, a set of APIs had been prioritized and classified. The data from that work were presented to the fifty-sixth ECSPP and had been integrated into an updated version of the WHO Biowaiver List (see Annex 11). Professor del Val Bermejo Sanz also summarized the results of a short-term exploratory study undertaken in cycle IV to consider API stability under pH conditions representative of the stomach and small intestine, as recommended by the fifty-fifth ECSPP. The study had involved measuring API stability for a period equivalent to the estimated in vivo contact of the substance in gastric fluid (for example, 1 hour at pH 1.2, 37 °C) and small intestinal fluid (for example, 3–6 hours at pH 6.8, 37 °C) and quantifying the parent drug molecule with the validated analytical method. Overall, no stability problems had been observed for the APIs studied in cycle IV.

The ECSPP was then presented with a list of 12 APIs as the proposed focus of cycle V of the WHO Biowaiver Project in 2022 (Table 1). That list emerged from initial discussions with PQT/MED followed by a round of public consultation from September to October 2021. It included three APIs that were listed as alternatives to the main selection in case of logistical or procedural problems.

Table 1
 Prioritized APIs proposed for study in cycle V of the WHO Biowaiver Project

API in EML medicine	Therapeutic area	Indication	Highest therapeutic dose (mg)
Amitriptyline (hydrochloride)	Medicines for mental and behavioural disorders	Medicines used in depressive disorders	75
Amlodipine (maleate, mesylate or besylate)	Cardiovascular medicines	Antihypertensive medicines	10
Bisoprolol (fumarate)	Cardiovascular medicines	Antihypertensive medicines	20
Clindamycin (hydrochloride)	Antibacterials	Access group medicines	450
Fluconazole	Antifungal medicines	Cryptococcosis and candidosis	800
Hydralazine (hydrochloride)	Cardiovascular medicines	Antihypertensive medicines (pregnancy-induced hypertension)	100
Linezolid	Antibacterials	Antituberculosis medicines Antibiotics (reserve group)	600
Pyrazinamide^a	Antibacterials	Antituberculosis medicines	2000
Quinine (sulfate or bisulfate)	Antiprotozoal medicines	Antimalarial medicines	648
Ribavirin	Anti-infective medicines	For treating viral haemorrhagic fevers	600
Valganciclovir	Anti-infective medicines	For treating cytomegalovirus retinitis (CMVr)	900

Table 1 *continued*

API in EML medicine	Therapeutic area	Indication	Highest therapeutic dose (mg)
Zidovudine ^b	Anti-infective medicines	Nucleoside/nucleotide reverse transcriptase inhibitors (HIV)	300

Grey shading: APIs listed as alternatives in case of logistical or procedural problems.

^a Pyrazinamide as monocomponent and in fixed-dose combination with isoniazid (studied in cycle IV), ethambutol (studied in cycle IV) and rifampicin (listed in the WHO Biowaiver List).

^b Zidovudine as monocomponent and in fixed-dose combination with lamivudine (studied in cycle IV).

The ECSPP thanked all those involved in enabling the WHO Biowaiver Project to characterize the solubility profiles of prioritized APIs using experimental laboratory data. It emphasized the value of that work not only for bioequivalence but also for API and finished pharmaceutical products quality assessment.

The Expert Committee discussed various aspects of the project, including the impact of degradation kinetics on the exploratory stability studies performed as part of cycle IV. It suggested that the study design requirements for demonstrating API stability should be clarified.

The Expert Committee noted the plans for publishing solubility study results beyond the WHO Technical Report Series to raise awareness about WHO's work on bioequivalence, including the WHO Biowaiver Project.

The Expert Committee also emphasized the importance of considering the impacts of polymorphism on API solubility. It suggested assessing the feasibility of including information on polymorphism (where applicable and when available) for each API studied when updating the WHO Biowaiver List.

The Expert Committee agreed to integrate the results of cycle IV into the Biowaiver List (Annex 11). It further suggested promoting the project's results through presentations at scientific conferences and publication in peer-reviewed and open-access journals, and through advocacy, engagement and partnership. The Expert Committee also accepted the prioritized APIs proposed for study in cycle V.

10.2 WHO guidance on registration requirements to establish interchangeability for multisource (generic) products

Dr John Gordon, Technical Adviser, updated ECSPP members on progress in considering a revision to *Multisource (generic) pharmaceutical products: guidelines on registration requirements to establish interchangeability* (9), as

recommended by the fifty-fifth ECSP. The revision had been recommended because, since the guidelines had been published in 2017, the International Council for Harmonisation of Technical Requirements for Pharmaceuticals for Human Use (ICH) had adopted, in 2019, a new harmonized guideline (M9) – *Biopharmaceutics Classification System-based biowaivers* (10).

Dr Gordon presented a comparison of the 2017 WHO guidelines and the 2019 ICH M9 guideline, noting that while they were very similar, the ICH M9 guideline was longer and so more detailed. One key difference was that the ICH M9 guideline allowed greater flexibility in terms of solubility assessment and permeability assessment for API classification within the Biopharmaceutics Classification System (BCS). It also recommended accepting larger allowable differences in excipient content for finished pharmaceutical products containing Class III APIs. The ICH assumed that those changes would make it easier to obtain BCS-based biowaivers, while still maintaining an acceptable level of risk.

Another notable difference was the ICH's recommended use of rotational speeds of 50 rotations per minute (rpm) for dissolution studies using the paddle apparatus, which was a tighter requirement than the 75 rpm speed recommended by WHO guidance. The M9 made that recommendation based on current practice by its member regulatory authorities and based on literature suggesting that 75 rpm might reduce the ability of the *in vitro* method to detect differences between products that could be seen in *in vivo* studies.

The Expert Committee discussed the proposal for harmonizing WHO recommendations for BCS-based biowaivers with those detailed in the ICH M9 guideline. It noted that many regulatory authorities, including several stringent regulatory authorities (SRAs), were already using the new ICH M9 guideline, as was the WHO PQT/MED (from May 2021). The Expert Committee further noted that the ICH M9 guideline was not the only ICH guideline relevant to bioequivalence that was being developed or revised, and that some of those under development – including guideline M13 on bioequivalence for immediate-release solid oral dosage forms (11) – were not expected to be ready for ICH adoption for some years. ECSP members suggested that it would be useful to have an overview of all the relevant ICH guidelines under development or revision and to keep track of their progress so that corresponding WHO harmonization efforts could be as efficient and timely as possible.

ECSP members acknowledged the importance of updating WHO guidance as soon as possible to resolve the discrepancies described by Dr Gordon, even if that meant splitting the existing guidelines into multiple documents. It also emphasized the need to ensure that all WHO Member States, including those that were not ICH members or observers, had an opportunity to comment on guidelines related to bioequivalence during their development phase. The extent to which WHO could facilitate that process was discussed, with ECSP members identifying a need to further explore the options.

The Expert Committee recommended that WHO requirements for BCS-based biowaivers be harmonized with those detailed in the ICH M9 guideline in a new guideline to be presented at the next ECSP. It further encouraged WHO to establish a group of experts to review and revise the document The impact of implementation of ICH guidelines in non-ICH countries (12).

10.3 Update on WHO-listed authorities

Dr Alireza Khadem Broojerdi, Regulatory Systems Strengthening Team, updated ECSP members on the development and implementation of a framework for evaluating and publicly designating regulatory authorities as WHO-listed authorities (WLAs). The framework aimed to provide a transparent and evidence-based pathway for regulatory authorities operating at an advanced level of performance to be globally recognized, and was intended to replace the concept of a stringent regulatory authority (SRA). It was hoped that implementing the WLA framework would improve access and supply of safe, effective and quality medical products, and optimize use of limited resources by facilitating reliance. The WLA initiative was also expected to foster regulatory convergence, help harmonize approaches and support international cooperation.

The WLA framework comprised a policy for evaluating and designating WLAs (which had been published in June 2021) as well as operational guidance and a manual for performance evaluation. Interim versions of the operational guidance and manual for performance evaluation had been published in March 2022, following international consultative stakeholder meetings, broad public consultations and technical working group discussions. Those interim versions would be piloted, revised and refined over six months before being replaced with final versions before the end of 2022.

The Global Benchmarking Tool remained the foundation for classifying regulatory systems according to maturity level and, as set out in the WLA policy, regulatory authorities that had attained overall maturity level 3 were eligible for consideration as a WLA. In early 2022, as part of the transition from SRAs to WLAs, all regulatory authorities on the public WHO interim list of national regulatory authorities had been placed on a transitional WLA list. The list would be valid for five years, during which time national regulatory authorities on the list would be evaluated against WLA requirements. Those transitional arrangements would not affect prequalification procedures.

The Expert Committee discussed various aspects of the WLA framework, including the performance evaluation indicators and tools, customized pathways for SRAs, and the structure of the advisory group that would act as the governing body for the WLA process.

The Expert Committee noted the update.

10.4 WHO Certification Scheme on the quality of pharmaceutical products moving in international commerce

ECSP members were updated by correspondence on progress in revising the WHO Certification Scheme on the quality of pharmaceutical products moving in international commerce, as twice recommended by the ECSP.

The scheme deterred the export, import and smuggling of falsely labelled, spurious, counterfeited or substandard pharmaceutical preparations. It had originally been established through World Health Assembly resolution WHA22.50. All subsequent changes had similarly been recommended and endorsed through World Health Assembly resolutions. Because of that, internal discussions were still ongoing to confirm the next steps after the fifty-fifth ECSP endorsed the revised Certification Scheme in 2020.

After the revised proposal was published in the report of the fifty-fifth ECSP, editorial changes were required, and the WHO Secretariat had received some concerns about proposed changes and potential implementation issues.

The Brazilian Health Regulatory Agency (ANVISA) had indicated its availability to be part of a group of experts to address technical and implementation issues of the revised Certification Scheme.

The Expert Committee noted the update and endorsed the proposal to establish a group of experts to help the WHO Secretariat address technical and implementation issues of the revised Certification Scheme on the quality of pharmaceutical products moving in international commerce, including developing a question and answer document, if necessary.

10.5 Recommendations from the virtual consultation on regulatory guidance for multisource products

ECSP members were updated by correspondence on the annual consultation on regulatory guidance for multisource products between the Norms and Standards for Pharmaceuticals Team and the PQT/MED assessment group.

This annual meeting provided a regular platform for the two teams to exchange information on current and future activities in the areas of quality and bioequivalence, supported by experts in the field. Participants were updated on a range of activities aimed at supporting prequalification applicants when designing bioequivalence studies for prequalification.

- **WHO Biowaiver Project cycle V (2022).** The group of experts had suggested including solubility information per highest therapeutic dose of each API indication (as applicable) when updating the WHO Biowaiver List and planning the forthcoming cycles of the WHO Biowaiver Project. It had also agreed a potential set of APIs for cycle V for presentation to the ECSP (see section 10.1).

- **Latin America Biowaiver Project.** The group of experts was informed about the International Pharmaceutical Federation's Biowaiver Project in Latin America. The group supported improvement in awareness about quality of medicines in the region, noting the gaps in knowledge, especially concerning biowaivers and the requirements for bioequivalence studies.
- **Product-specific guidance on bioequivalence study design.** Following a recommendation from the fifty-fifth ECSP and a public consultation, the group of experts had considered the proposal to present product-specific guidance texts on how to design bioequivalence studies to the ECSP together with the feedback received during the public consultation. The group highlighted the complexity of the task and the requirement for significant expertise and resources to maintain the PQT/MED guidance, which might not be available within the ECSP. It suggested establishing a group of experts to assess all feedback received and propose a way forward to the ECSP.
- **WHO guidance registration requirements to establish interchangeability for generics.** The group of experts considered recently published and upcoming ICH guidelines on BCS-based biowaivers (10) and bioequivalence for immediate-release solid oral dosage forms (11). It did not expect significant changes to be needed in WHO guidelines or in the WHO Biowaiver Project.

The Expert Committee noted the update and recommended establishing a group of experts to assess all feedback received on the working document Inquiry regarding WHO product-specific guidance on the design of bioequivalence studies, and to propose a way forward.

10.6 Ongoing activities and proposed new topics for regulatory guidance and model schemes

Dr Gwaza presented a plan for ongoing work and proposed topics for revision or new regulatory guidance to ECSP members. All quality assurance guidelines were developed following recommendations by WHO governing bodies, ICDRA, the ECSP and international organizations (including United Nations agencies and other WHO programmes), or in response to major public health needs.

Dr Gwaza identified four proposed guidelines for development:

- WHO/UNFPA condom quality assurance;
- WHO/UNFPA female condom generic specification;

- WHO guidance on management of waste and wastewater from pharmaceutical manufacturing, with a focus on antimicrobials (see section 8.7);
- WHO/IAEA good manufacturing practices for cold kits for radiopharmaceutical products (already under development).

Dr Gwaza also updated the Expert Committee on ongoing work to revise *WHO good practices for pharmaceutical quality control laboratories* (Annex 1, TRS 957, 2010) and informed ECSP members of the potential need to revise a further two existing guidelines: *Supplementary guidelines for the manufacture of pharmaceutical excipients* (Annex 5, TRS 885, 1999), and *Guidelines for medicine donations, revised 2010*. In addition, Dr Gwaza noted that two published articles had raised concerns about the recently published *Good chromatography practices* (Annex 4, TRS 1025, 2020), which warranted further investigation by a group of experts to analyse the comments and concerns raised and recommend appropriate action in preparation for the next ECSP.

In each case, development of the new or revised guidelines would follow the established procedure for the development of WHO medicines quality assurance guidelines (13). The WHO Secretariat proposed establishing groups of experts to advance work on each of those guidelines in preparation for the next ECSP meeting.

ECSP members discussed each item of the workplan.

The Expert Committee adopted the workplan as presented and agreed to establish groups of experts to advance work on each of the proposed guidelines and new topics.

11. Miscellaneous: update on COVID-19 activities

Dr Luther Gwaza updated ECSPP members on a range of activities undertaken in response to the COVID-19 pandemic, which included developing and sharing specifications, leveraging existing guidelines and supporting new activities.

11.1 Therapeutic specifications

The Norms and Standards for Pharmaceuticals Team had worked with the Medical Devices and Diagnostics Team to revise the monograph on oxygen in *The International Pharmacopoeia* (see section 6.3.1). The revised monograph clarified that both oxygen products could be administered safely to patients and put an end to discussions on whether industrial oxygen could be used for human application. Only medicinal oxygen of defined quality, which had been tested and met the authorized specifications for its identity, purity and content, and which was produced, stored and distributed in adherence with good practices, should reach the patient.

Other recent activities to improve and include monographs in *The International Pharmacopoeia* could also have a direct bearing on treating COVID-19. Those included revising the monograph for dexamethasone phosphate injection to improve the test for related substances; adopting new monographs for remdesivir and remdesivir intravenous infusion; and developing new monographs for molnupiravir and molnupiravir capsules (see section 6.3.1).

In February 2020, the IMWP had issued a global pharmacopoeial alert for COVID-19 to enable rapid discussions among pharmacopoeias that could support the global response to COVID-19, including by providing guidance and information to manufacturers, regulators and stakeholders on critical medicines. For example, world pharmacopoeias had collaborated to map the monograph availability of COVID-19 investigated medicines around the world (14). In addition, many pharmacopoeias had improved the accessibility of supportive pharmacopoeial texts by making them freely available online.

The IMWP had also established a subgroup of interested pharmacopoeias to explore the development of IMWP monographs for new therapeutics under clinical trial for COVID-19 treatment. While the manufacturer of remdesivir was not interested in participating in the project, the manufacturer of favipiravir was working with the subgroup towards a collaborative IMWP specification (though a draft monograph had yet to be developed).

11.2 Existing guidance

The Norms and Standards for Pharmaceuticals Team had collated the most relevant ECSPP-adopted guidance in the areas of pharmaceutical quality assurance and regulation for COVID-19 medicines (15). The list was structured

to mirror the different phases of a product's life cycle. It was intended to support the development, production, evaluation, distribution, and quality control of medicines that might be, or were already being, used to treat COVID-19.

The Norms and Standards for Pharmaceuticals Team had also contributed to a question-and-answer document prepared by PQT/INS to address queries about regulatory flexibility during the COVID-19 pandemic (16).

11.3 New activities

Dr Gwaza summarized two other areas of new activity related to COVID-19 that had been ongoing since the previous ECSPP meeting.

- **Development of new or updated guidelines**, as suggested by PQT/INS and local production teams, including guidelines on transfer of technology in pharmaceutical manufacturing (see section 8.3), GMP for medicinal gases (see section 8.4), GMP for research and development facilities (see section 8.5), and GMP for investigational pharmaceutical products for clinical trials in humans (see section 8.6).
- **Expedited biowaiver studies**, in particular the expedited solubility characterization of dexamethasone tablets, which had been published in the report of the fifty-fifth ECSPP meeting and had been integrated into the WHO Biowaiver List (see Annex 11).

ECSPP members also acknowledged the value of the prequalification guidance and support provided by WHO in the context of the COVID-19 pandemic.

The Expert Committee noted the update.

12. Closing remarks

The Chair thanked the ECSPP for its standard-setting work, which had an impact for many people in all of WHO's Member States by enabling access to quality-assured medical products. She thanked the WHO Secretariat for its work in supporting the Expert Committee, and thanked all ECSPP members for their active participation. Dr Clive Ondari thanked participants for their contributions and for the high-quality discussions held during the meeting. He thanked the Chair, the Vice-Chair and the rapporteurs for contributing to an efficient meeting. The Chair closed the meeting.



13. Summary and recommendations

The WHO ECSPP advises the Director-General of WHO in the area of medicines quality assurance. It oversees the maintenance of *The International Pharmacopoeia* and provides guidance for use by relevant WHO units and regulatory authorities in WHO Member States, to ensure that medicines meet unified standards of quality, safety and efficacy. The ECSPP's guidance texts are developed through a broad consensus-building process, including iterative public consultation. Representatives from international organizations, state actors, non-state actors, pharmacopoeias and relevant WHO departments are invited to the ECSPP's annual meetings to provide updates and input to the Expert Committee's discussions.

At its fifty-sixth meeting, held virtually from 25 April to 2 May 2022, the ECSPP received updates on cross-cutting issues from other WHO bodies, including the ECBS, the Expert Committee on the Selection and Use of Essential Medicines, the Prequalification of Medicines Programme, the MSM, and ICDRA. Other WHO teams updated the ECSP on WHO's latest work to support the development of INNs and on efforts to establish WLAs. Updates on collaborative projects were also provided by partner organizations, including the IMWP, the IAEA and the UNFPA.

The EDQM updated the ECSPP on its activities as the custodial centre in charge of ICRS for use with monographs of *The International Pharmacopoeia*. Results from the latest phase of the External Quality Assurance Assessment Scheme, which is organized by WHO with the assistance of the EDQM, were also shared with the ECSPP.

The ECSPP reviewed new and revised specifications and general texts for quality control testing of medicines for inclusion in *The International Pharmacopoeia*. The Expert Committee adopted six guidelines and 18 pharmacopoeial texts (one general chapter and 17 new and revised monographs), and confirmed the release of 11 new ICRS established by the custodial centre for use in connection with *The International Pharmacopoeia*.

The ECSPP reviewed proposals for new and updated quality assurance and regulatory guidance, adopting three new guidelines and decisions. The ECSPP also updated the WHO Biowaiver List as an annex to its report.

The sections that follow summarize the specific decisions and recommendations made by the ECSPP during its fifty-sixth meeting in 2022.

13.1 Guidelines and decisions adopted and recommended for use

The following guidelines and decisions were adopted and recommended for use:

- *WHO good manufacturing practices for sterile pharmaceutical products* (Annex 2)

- *IAEA/WHO guideline on good manufacturing practices for investigational radiopharmaceutical products* (Annex 3)
- *WHO guidelines on technology transfer in pharmaceutical manufacturing* (Annex 4)
- *WHO good manufacturing practices for medicinal gases* (Annex 5)
- *WHO good practices for research and development facilities of pharmaceutical products* (Annex 6)
- *WHO good manufacturing practices for investigational products* (Annex 7)
- *Points to consider for setting the remaining shelf-life of medical products upon delivery* (Annex 8)
- *WHO/UNFPA guidance on natural rubber latex male condom stability studies* (Annex 9)
- *WHO/UNFPA technical specification for TCU380A intrauterine device* (Annex 10)
- *WHO Biowaiver List: proposal to waive in vivo bioequivalence requirements for WHO Model List of Essential Medicines immediate-release, solid oral dosage forms* (Annex 11)

13.2 Texts adopted for inclusion in *The International Pharmacopoeia*

The ECSP adopted a series of chapters and monograph, as listed below.

13.2.1 General chapters

- Chromatography (new)

13.2.2 Monographs

COVID-19 therapeutics

- medicinal oxygen (revision)
- molnupiravir (new)
- molnupiravir capsules (new)

Medicines for maternal, infant, child and adolescent health

- norethisterone enantate (revision)
- norethisterone enantate injection (new)
- ulipristal acetate (new)
- ulipristal acetate tablets (new)

Antimalarial medicines

- artemimol (revision)

Antituberculosis medicines

- isoniazid (revision)
- isoniazid tablets (revision)
- linezolid (new)
- linezolid tablets (new)

Antiviral medicines, including antiretrovirals

- lamivudine (revision)
- lamivudine oral solution (revision)
- dolutegravir dispersible tablets (new)
- dolutegravir, lamivudine and tenofovir tablets (new)
- tenofovir disoproxil fumarate (revision)

13.2.3 International Chemical Reference Substances (ICRS)

The ECSPP confirmed the release of the following ICRS that have been newly characterized by the custodial centre EDQM:

- ivermectin ICRS, batch 1
- alpha-artemether ICRS, batch 2
- ciprofloxacin impurity A ICRS, batch 1
- levamisole hydrochloride ICRS, batch 1
- ciprofloxacin hydrochloride ICRS, batch 2
- daclatasvir for system suitability ICRS, batch 1
- daclatasvir for peak identification ICRS, batch 1
- daclatasvir dihydrochloride ICRS, batch 1
- amodiaquine hydrochloride ICRS, batch 2
- dexamethasone sodium phosphate for assay ICRS, batch 1
- carbamazepine ICRS, batch 2.

13.3 Recommendations

The ECSPP made a series of recommendations related to quality assurance, as listed below. Progress on the suggested actions will be reported to the ECSPP at its fifty-seventh meeting in 2023.

The Expert Committee recommended that the WHO Secretariat, in collaboration with experts as appropriate, should take the actions listed next.

13.3.1 *The International Pharmacopoeia*

- Continue development of monographs, general methods and texts and general supplementary information, in accordance with the 2022–2023 workplan and as decided at the meeting.
- Continue collaborating with IAEA to update texts on radiopharmaceuticals in *The International Pharmacopoeia*.
- Develop a policy on identity testing for discussion at the next informal consultation, and provide an update to the next ECSP.
- Consider developing a monograph for arteminol and piperazine soft gelatin capsules in *The International Pharmacopoeia*.
- Consider revising the general capsules chapter to include a paragraph on some of the challenges posed by hydroxypropylmethylcellulose (HPMC) capsule shells.

13.3.2 **Quality control: national laboratories**

- Continue the EQAAS in support of national and regional PQCLs, including continuing the post-assessment assistance programme.
- Present the outcome of the survey, and any resulting action taken, that was performed following the high failure in disintegration testing in the last EQAAS.
- Provide an update on the costing structure for the EQAAS at the next ECSP meeting.

13.3.3 **Good manufacturing practices and related areas**

- Continue collaborating with IAEA to develop GMP guidelines for cold kits for radiopharmaceuticals.
- Develop a new guideline on management of waste and wastewater from pharmaceutical manufacturing, in collaboration with UNEP and with a focus on antimicrobials.
- Update *WHO good practices for pharmaceutical quality control laboratories*.
- Update *WHO guidelines for medicine donations*.
- Analyse the comments and concerns raised about the recently published *Good chromatography practices* guideline and recommend appropriate action in preparation for the next ECSP.

13.3.4 Distribution and supply chain

- Continue collaborating with UNFPA to update prequalification guidance for contraceptive devices and condoms.

13.3.5 Regulatory mechanisms

- Start the next phase of the WHO Biowaiver Project (cycle V) to continue the BCS-based classification of nine further APIs.
- Promote the results of the WHO Biowaiver Project through presentations at scientific conferences and publication in peer-reviewed and open-access journals, and through advocacy, engagement and partnership.
- Establish a group of experts to assess all feedback received on the working document *Inquiry regarding WHO product-specific guidance on how to design bioequivalence studies* and to propose a way forward.
- Develop a new guideline to harmonize WHO requirements for BCS-based biowaivers with those detailed in the ICH M9 guideline.
- Establish a group of experts to review and revise the existing document *The impact of implementation of ICH guidelines in non-ICH countries (12)*.
- Establish a group of experts to help address technical and implementation issues of the revised WHO Certification Scheme on the quality of pharmaceutical products moving in international commerce.
- Establish groups of experts to advance the preparation of topics for the next meeting.

13.3.6 Other

- Continue to serve as the Secretariat for IMWPs, and strive to publish articles about the IMWP in open-access peer-reviewed journals.
- Continue updating the Quality Assurance of Medicines Terminology Database on an annual basis.
- Promote the use of existing guidelines and guidance in the context of the COVID-19 pandemic.

Acknowledgements

The Expert Committee acknowledges the following contributors at WHO:

Dr A. Al-Nuseirat, WHO Regional Office for the Eastern Mediterranean; Dr S. Azatyan, Team Lead, Regulatory Convergence and Networks; Professor H.H. Balkhy, Assistant Director-General, Antimicrobial Resistance; Dr R. Balocco, Unit Head, International Nonproprietary Names and Classification of Medical Products; Ms B. Cappello, Essential Medicines; Dr D. Catsoulacos, Inspection Services; Mr M. Chafai, Inspection Services; Dr A. Chemwolo, Medicines Assessment; Ms H.L. Choi, Medicines Assessment; Mr M. Conrad, Inspection Services; Dr R.P. Pinto De Sá Gaspar, Director, Regulation and Prequalification Department; Ms S. Croft, Inspection Services; Dr J. Dong, Local Production and Assistance; Dr S. Estevão Cordeiro, Norms and Standards for Pharmaceuticals; Mr M. Freitas Dias, WHO Regional Office for the Americas; Dr V. Gigante, Team Lead, One Health Research Priority-setting and Synergy; Dr J. Gouws, Team Lead, Inspection Services; Dr L. Gwaza, Team Lead, Norms and Standards for Pharmaceuticals; Mr P. Jimenez, Radiology, WHO Regional Office for the Americas; Ms S. Jones, Norms and Standards for Pharmaceuticals; Dr A. Khadem Broojerdi, Acting Team Lead, Regulation and Safety; Dr I. Knezevic, Team Lead, Norms and Standards for Biological Products; Dr H. Langar, WHO Regional Office for the Eastern Mediterranean; Ms S. Laroche, Global Supply Policies; Dr S. Lewis, Consultant, Norms and Standards for Pharmaceuticals; Dr D. Lei, Norms and Standards for Biological Products; Ms H. Martin-Ballester, Medicines Assessment; Mr D. Mubangizi, Unit Head, Prequalification; Mr M. Musonda, Prequalification; Mr L. Nzumbu, Medicines Assessment; Dr M. Perez, Radiation and Health; Dr A. Porrás, Unit Chief, Medicines and Health Technologies, WHO Regional Office for the Americas; Dr C. Ondari, Director, Health Product Policy and Standards; Dr I.D. Ortega, Medicines Assessment; Dr R. Ostad Ali Dehaghi, Regulatory Systems Strengthening; Mr M. Refaat, Regulatory Systems Strengthening; Dr M. Roldao Santos, Facilitated Product Introduction; Mr V. Sachdeva, Inspection Services; Ms A. Sands, Incidents and Substandard/Falsified Medical Products; Dr H. Schmidt, Norms and Standards for Pharmaceuticals; Dr M. Shridhar, WHO Regional Office for South-East Asia; Mr H. Sillo, Unit Head, Regulation and Safety; Dr M. Simão, Assistant Director-General, Access to Medicines and Health Products; Dr M. Stahl, Team Lead, Medicines Assessment; Dr P. Steyn, Contraception and Fertility Care; Mrs I. Streipa, Inspection Services; Mrs M. Valentin, Regulatory Convergence and Networks; Dr A. Velazquez Berumen, Team Lead, Medical Devices and Diagnostics; Ms L.A. Velez Ruiz Gaitan, Medical Devices and Diagnostics; Ms C. Vogel, Office of the Publisher; Mr W.Z. Worku, Medicines Assessment; and Mrs H. Yin, Medicines Assessment.

Technical guidance included in this report was prepared with the financial assistance of the Bill & Melinda Gates Foundation, the German Federal

Ministry of Health, the Global Fund to Fight AIDS, Tuberculosis and Malaria and the United Nations Development Programme.

The Expert Committee also acknowledges with thanks the valuable contributions made to its work by the following agencies, institutions, organizations, pharmacopoeias, WHO collaborating centres, WHO programmes (especially the Regulatory and Prequalification Teams) and individuals:

Agencia Estatal de Medicamentos y Tecnologías en Salud, La Paz, Bolivia; Asia Industrial Gases Association; Brazilian Health Surveillance Agency, Brasília, Brazil; Directorate General of Pharmaceutical Affairs and Drug Control, Ministry of Health, Muscat, Oman; European Commission, Brussels, Belgium; European Directorate for the Quality of Medicines and HealthCare, Council of Europe, Strasbourg, France; European Industrial Gases Association, European Medicines Agency, Amsterdam, the Netherlands; Global Self-Care Federation (formerly World Self Medication Industry), Nyon, Switzerland; International Atomic Energy Agency, Vienna, Austria; International Federation of Pharmaceutical Manufacturers and Associations, Geneva, Switzerland; International Generic and Biosimilar Medicines Association, Brussels, Belgium; International Pharmaceutical Excipients Council Federation ASBL, Brussels, Belgium; International Pharmaceutical Federation, The Hague, the Netherlands; International Society for Pharmaceutical Engineering, Tampa (FL), United States of America; Medicines for Europe, Brussels, Belgium; National Drug Authority, Kampala, Uganda; Parenteral Drug Association, Bethesda (MD), United States of America; Pharmaceutical Inspection Co-operation Scheme, Geneva, Switzerland; Saudi Food and Drug Authority, Riyadh, Saudi Arabia; Society of Nuclear Medicine and Molecular Imaging, Virginia, United States of America; Therapeutic Goods Administration, Woden, ACT, Australia; Turkish Medicines and Medical Devices Agency, Ankara, Türkiye; United Nations Children's Fund, Supply Division, Copenhagen, Denmark; United Nations Development Programme, Châtelaine, Switzerland; United Nations Industrial Development Organization, Geneva, Switzerland; United Nations Population Fund, Copenhagen, Denmark.

Therapeutic Goods Administration, Woden, Australia; Directorate General of Drug Administration, Dhaka, Bangladesh; K.U. Leuven, Leuven, Belgium; Chengdu Institute for Food and Drug Control, Sichuan, China; Chongqing Institute for Food and Drug Control, Chongqing City, China; Dalian Drug Quality Control Institute, Dalian City, China; Guangzhou Municipal Institute for Drug Control, Guangzhou, China; Hubei Institute For Drug Control, Wuhan, China; Jiangsu Institute for Food and Drug Control, Nanjing, China; National Institutes for Food and Drug Control, Beijing, China; Shandong Institute for Food and Drug Control, Shandong, China; Shenzhen Institute for Drug Control Jiangsu Province, Shenzhen, China; Sichuan Institute for Food and Drug Control, Sichuan, China; Suzhou Institute for Drug Control, Jiangsu, China; Tianjin Institute for Drug Control, Tianjin, China; Wuxi Institute For

Drug Control, Jiangsu, China; Xiamen Institute for Food and Drug Control, Xiamen, China; Zhejiang Institute for Drug and Food Control, Zhejiang, China; Medicamentos y Productos Biológicos, Instituto Nacional de Vigilancia de Medicamentos y Alimentos, Bogotá, Colombia; Laboratorio de Análisis y Asesoría Farmacéutica, Facultad de Farmacia, Universidad de Costa Rica, San José, Costa Rica; Laboratorio de Normas y Calidad de Medicamentos, Caja Costarricense de Seguro Social, Universidad de Costa Rica, Alajuela, Costa Rica; Agency for Medicinal Products and Medical Devices of Croatia, Official Medicines Control Laboratory Division, Zagreb, Croatia; National Quality Control Laboratory of Drug and Food, National Agency for Food and Drug Control, Yogyakarta, Indonesia; Mission for Essential Drugs and Supplies, Nairobi, Kenya; Arwan Pharmaceutical Industries Lebanon s.a.l., Jadra, Lebanon; Laboratoire de Contrôle de Qualité des Médicaments, Agence du Médicament de Madagascar, Antananarivo, Madagascar; Laboratoire National de Contrôle de Qualité des Médicaments, Nouakchott, Mauritania; Quality Surveillance Laboratory, Windhoek, Namibia; Instituto Especializado de Análisis, Universidad de Panamá, Panama; Centro Nacional de Control de Calidad, Instituto Nacional de Salud, Lima, Peru; Laboratoire National de Contrôle des Médicaments, Dakar Etoile, Senegal; Drug Quality Control Laboratory, Ministry of Health, Victoria, Seychelles; National Drug Quality Assurance Laboratory, Ministry of Health, Colombo, Sri Lanka; National Drug Quality Control Laboratory, Directorate General of Pharmacy, Federal Ministry of Health, Khartoum, Sudan; School of Pharmacy, Muhimbili University of Health and Allied Sciences, Dar es Salaam, United Republic of Tanzania; Bureau of Drug and Narcotic, Department of Medical Sciences, Ministry of Public Health, Nonthaburi, Thailand; National Drug Quality Control Laboratory, National Drug Authority, Kampala, Uganda; Laboratory of Pharmaceutical Analysis, State Pharmacological Centre, Ministry of Health, Kyiv, Ukraine; Laboratorio Control de Productos Ministerio de Salud Pública, Comisión Para El Control de Calidad de Medicamentos, Montevideo, Uruguay; National Institute of Drug Quality Control, Hanoi, Viet Nam; Zambia Medicines Regulatory Authority, Lusaka, Zambia; Medicines Control Authority of Zimbabwe, Harare, Zimbabwe; Mekelle University, School of Pharmacy, Pharmaceutical Analysis and Quality Assurance, Mekelle, Ethiopia; Federal Institute for Drugs and Medical Devices, Bonn, Germany; United States Pharmacopeia, Accra, Ghana; Central Drugs Laboratory, Ministry of Health and Family Welfare, Kolkata, India; Institut für Pharmazeutische und Angewandte Analytik, Bremen, Germany.

Farmacopea Argentina, Buenos Aires, Argentina; Farmacopeia Brasileira, Brasília DF, Brazil; Chinese Pharmacopoeia Commission, Beijing, China; Pharmacopoeial Committee of the Eurasian Economic Union, Moscow, Russian Federation; European Pharmacopoeia, European Directorate for the Quality of Medicines and HealthCare, Council of Europe, Strasbourg, France; Pharmacopée

française, Agence Nationale de Sécurité du Médicament et des Produits de Santé, Saint-Denis, France; German Pharmacopoeia Commission, Bonn, Germany; Indian Pharmacopoeia Commission, Ghaziabad, India; Indonesian Pharmacopoeia Commission, Jakarta Pusat, Indonesia; The International Pharmacopoeia, World Health Organization, Geneva, Switzerland; Committee of the Japanese Pharmacopoeia, Pharmaceutical Affairs Food Sanitation Council, Tokyo, Japan; Mexican Pharmacopoeia, México DF, Mexico; Pharmacopoeia of the Republic of Korea, Chuncheonbuk-do, Republic of Korea; Swiss Pharmacopoeia, Bern, Switzerland; Turkish Medicines and Medical Devices Agency, Department of Analysis and Control Laboratories, Vice Presidency of Economic Assessments and Laboratory Services, Ankara, Turkey; Pharmacopoeia of Ukraine, Ukrainian Scientific Pharmacopoeial Center for Quality of Medicines, Kharkov, Ukraine; British Pharmacopoeia Commission, Medicines and Healthcare Products Regulatory Agency, London, United Kingdom; United States Pharmacopoeia, Rockville (MD), United States of America.

Therapeutic Goods Administration Laboratories, Woden, ACT, Australia; WHO Collaborating Centre for Drug Quality Assurance, National Institutes for Food and Drug Control, Beijing, China; WHO Collaborating Centre for Drug Quality Assurance, Pharmaceutical Laboratory, Centre for Analytical Science, Health Sciences Authority, Singapore; WHO Collaborating Centre for Quality Assurance of Drugs, North-West University, Potchefstroom, South Africa; WHO Collaborating Centre for Quality Assurance of Essential Drugs, Bureau of Drug and Narcotic, Department of Medical Sciences, Ministry of Public Health, Nonthaburi, Thailand.

Antimicrobial Resistance Division, WHO, Geneva, Switzerland; Regulation and Prequalification, WHO, Geneva, Switzerland; Global Malaria Programme, Universal Health Coverage/Communicable and Noncommunicable Diseases, WHO, Geneva, Switzerland; Global Tuberculosis Programme, WHO, Geneva, Switzerland; HIV/AIDS, WHO, Geneva, Switzerland; International Nonproprietary Names and Classification of Medical Products, WHO, Geneva, Switzerland; Office of the Legal Counsel, WHO, Geneva, Switzerland; Prequalification, WHO, Geneva, Switzerland; Prevention and Control of Noncommunicable Diseases, WHO, Geneva, Switzerland; Regulation and Prequalification, WHO, Geneva, Switzerland; Technologies, Standards and Norms, WHO, Geneva, Switzerland.

WHO Regional Office for Africa, Brazzaville, Congo; WHO Regional Office for the Americas, Washington DC, United States of America; WHO Regional Office for the Eastern Mediterranean, Cairo, Egypt; WHO Regional Office for Europe, Copenhagen, Denmark; WHO Regional Office for South-East Asia, New Delhi, India; WHO Regional Office for the Western Pacific, Manila, Philippines.

Professor E. Adams, Pharmaceutical Analysis, K.U. Leuven, Leuven, Belgium; Dr A. Adisa, Principal Evaluator, Therapeutic Goods Administration, Woden, Australia; Dr N.R.A. Al Mazrouei, Abu Dhabi, United Arab Emirates; Mr S. Alnabhan, Saudi Food and Drugs Authority, Riyadh, Saudi Arabia; Ms R. Alnaimat, Jordan Food and Drugs Authority, Amman, Jordan; Ms M. Al Khreishah, Jordan Food and Drugs Authority, Amman, Jordan; Dr M.H. Al Rubaie, Director General, Ministry of Health, Muscat, Oman; Dr M. Assalone, Technical Secretary of Argentinian Pharmacopoeia, Medicines National Institute, Buenos Aires, Argentina; Mr F. Bahurire, National Drug Authority, Kampala, Uganda; Mr N. Banerjee, Microbiology Head, Aurobindo Pharma, East Windsor (NJ), United States of America; Mr I. Basade, Mylan Laboratories Ltd, Hyderabad, India; Professor M. Bermejo-Sanz, Department of Pharmaceutical Technology and Pharmaceutics, Universidad Miguel Hernández de Elche, Alicante, Spain; Dr F. Blanco, Spanish Agency of Medicines and Medical Devices, Madrid, Spain; Mr B. Boedecker, Hanover, Germany; Dr P. Borman, GlaxoSmithKline, Hertfordshire, United Kingdom; Professor R. Boudet-Dalbin, Paris, France; Mr R.M. Bretas, Good Manufacturing Practice Inspector, Health Regulatory Agency, Brasília, Brazil; Ms J. Briggs, Management Sciences for Health, Arlington, United States of America; Dr M. Brits, Operations Manager, Research Institute for Industrial Pharmacy Inc., Centre for Quality Assurance of Drugs, North-West University, Potchefstroom, South Africa; Dr R. Bose, Deputy Drugs Controller, Central Drugs Standard Control Organization, Ministry of Health and Family Welfare, New Delhi, India; Mr Y. Cao, Deputy Director of the 4th Division Inspections, Centre for Food and Drug Inspection of National Medical Products Administration, Beijing, China; Dr N. Cappuccino, Chair, Science Committee, International Generic and Biosimilar Medicines Association, Geneva, Switzerland; Dr J.M. Caudron, United Nations Development Programme, Châtelaine, Switzerland; Mr S. Cavalheiro Filho, Assistant Manager, Regulatory Affairs, International Federation of Pharmaceutical Manufacturers and Associations, Geneva, Switzerland; Dr R. Conocchia, European Medicines Agency, Amsterdam, the Netherlands; Dr A.R. Cornelio Geyer, Brazilian Health Surveillance Agency, Brasília, Brazil; Dr H. Corns, Principal Pharmacopoeial Scientist, Medicines and Healthcare Products Regulatory Agency, London, United Kingdom; Dr R.J. Crowe, Emory University Center for Systems Imaging, Atlanta, Georgia, United States of America; Professor T. Dekker, Research Institute for Industrial Pharmacy, North-West University, Potchefstroom, South Africa; Dr M.A. Desouky, Senior Inspector Pharmacist and Quality Coordinator, Central Administration of Pharmaceutical Affairs, Ministry of Health, Cairo, Egypt; Dr V. Dias Sousa, Directorate Advisor, Brazilian Health Surveillance Agency, Brasília, Brazil; Dr J. Díaz Tito, Instituto de Salud Pública, Ministerio de Salud, Santiago, Chile; Dr M. Dmitrieva, Scientific Secretary, Ukrainian Scientific Pharmacopoeial Center for Quality of Medicines, State Service of Ukraine on

Medicinal Products, Ministry of Health, Kharkov, Ukraine; Dr D. Dimas, Good Manufacturing Practice Inspector, National Organization for Medicines, Attiki, Greece; Mr J. Dobaria, Hetero Labs Ltd, Hyderabad, India; Dr P. Doerr, European Directorate for the Quality of Medicines and HealthCare, Council of Europe, Strasbourg, France; Mr E. Dong, Food and Drugs Administration, Maryland, United States of America; Dr S. Dragotakes, Committee on Radiopharmaceuticals, Society of Nuclear Medicine and Molecular Imaging, Virginia, United States of America; Mrs S. Dube-Mwedzi, South Africa Development Community, Medicines Regulatory Harmonization Project Coordinator, Zazibona Inspectorate, Medicines Control Authority of Zimbabwe, Harare, Zimbabwe; Mr M. Durschlag, Nitto BioPharma, Inc., San Diego, United States of America; Ms N. Elgueta, Institute of Public Health, Santiago, Chile; Dr C. Erbach, Valicare GmbH, Frankfurt, Germany; Ms L.B. Filier, Brazilian Health Surveillance Agency, Brasília, Brazil; Dr G. Fischer, Head of Quality Regulatory Intelligence, Boehringer Ingelheim Corporate Center GmbH, Rhein, Germany; Professor I. Fradi Dridi, Service Pharmacie, Centre National de Greffe de Moelle Osseuse, Faculté de Pharmacie de Monastir, Monastir, Tunisia; Dr A. Garcia-Arieta, Head of Service on Pharmacokinetics and Generic Medicines, Division of Pharmacology and Clinical Evaluation, Department of Human Use Medicines, Spanish Agency of Medicines and Medical Devices, Madrid, Spain; Dr V. Gershan, International Atomic Energy Agency, Vienna, Austria; Mr K. Ghasemi, Quality Assurance Specialist, United Nations International Children's Emergency Fund, Copenhagen, Denmark; Dr J. Gordon, Wolfville, Nova Scotia, Canada; Ms R.C. Guimarães, Quality Deputy Director, Bio-Manguinhos-Fiocruz, Rio de Janeiro, Brazil; Dr F. Hallouard, CHU de Saint-Étienne, Saint-Étienne, France; Ms R. Harrington, Food and Drug Administration, Maryland, United States of America; Mr O. Hawari, Quality Assurance Manager, External Collaborations, Hoffman La Roche, Mississauga, ON, Canada; Mr W. Heimes, Administration Manager, European Compliance Academy Foundation, Heidelberg, Germany; Ms M. Hirschhorn, Head, Quality and Chemistry Sector, Comisión para el Control de Calidad de Medicamentos, Montevideo, Uruguay; Dr Y. Hiyama, Division of Drugs, National Institute of Health Sciences, Tokyo, Japan; Mr P. van der Hoeven, Active Pharmaceutical Ingredients Committee, European Chemical Industry Council, Brussels, Belgium; Dr O. Holmberg, International Atomic Energy Agency, Vienna, Austria; Professor J. Hoogmartens, Catholic University of Leuven, Leuven, Belgium; Ms C.D. Jeffers, University of Alabama at Birmingham, Birmingham, United States of America; Dr U. Juárez-Sevilla, Mexican Pharmacopoeia, Mexico City, Mexico; Ms D. Jurman, Technical Officer, United Nations Population Fund, Bangkok, Thailand; Professor E.A. Kaale, School of Pharmacy, Muhimbili University of Health and Allied Sciences, Dar es Salaam, United Republic of Tanzania; Mrs K. Kikule, Management Sciences for Health, Arlington (VA), United States of America; Mr S. Kimatu,

Management Sciences for Health, Arlington (VA), United States of America; Mr S. Kisoma, Tanzania Medicines and Medical Devices Authority, Dar-es-Salaam, United Republic of Tanzania; Dr N.N.K. Kkrumah, Medicines Evaluation and Registration Department, Food and Drug Administration, Cantonment-Accra, Ghana; Dr P. Koch, Swiss Society of Radiopharmacy/Radiopharmaceutical Chemistry, Zurich, Switzerland; Mrs W. Kongsuk, Bureau of Drug and Narcotic, Department of Medical Sciences, Nonthaburi, Thailand; Dr S. Kopp, Geneva, Switzerland; Dr A. Korde, Technical Officer, Radioisotope Products and Radiation Technology Section, Division of Physical and Chemical Sciences, International Atomic Energy Agency, Vienna, Austria; Dr A. Krauss, Woden, Australia; Dr T. Kroon, General Electric Healthcare, Amsterdam, the Netherlands; Dr Z. Kusynova, Lead for Policy, Practice and Compliance, International Pharmaceutical Federation, The Hague, the Netherlands; Dr N.D. Kuwabara, Brazilian Health Surveillance Agency, Brasília, Brazil; Professor J. Ladutko Mikhailovna, Department of Technology of Dosage Forms, Federal State Budgetary Educational Institution of Higher Education, St Petersburg State Chemical Pharmaceutical University, Ministry of Health, Moscow, Russian Federation; Mr K. Laenen, Quality and Regulatory Affairs Manager, Medicines for Europe, Brussels, Belgium; Ms S. Laska, Food and Drugs Administration, Maryland, United States of America; Ms L. Lavergne, Technical Coordinator, Pharmacist, Quality Medicine for All, Paris, France; Professor B.J. Lee, College of Pharmacy, Ajou University, Suwon, Republic of Korea; Dr D. Leontiev, State Enterprise “Ukrainian Scientific Pharmacopoeial Center for Quality of Medicines”, Kyiv, Ukraine; Dr A. Lodi, Head of Laboratory, European Directorate for the Quality of Medicines and Health Care, Council of Europe, Strasbourg, France; Dr S. Logez, Procurement and Supply Management Specialist, United Nations Development Programme, Geneva, Switzerland; Ms S. Lohani, General Manager, Beximco Pharmaceuticals Ltd, Gazipur, Bangladesh; Dr A.L. Lopes da Silva, Health Regulation Specialist, Brazilian Pharmacopoeia Coordination, Brazilian Health Regulatory Agency, Brasília, Brazil; Ms M.Y. Low, Director, Pharmaceutical Division, Applied Sciences Group, Health Sciences Authority, Singapore; Professor M. McIntosh, Monash Institute of Pharmaceutical Sciences, Monash University, Parkville, Australia; Mr M. Meić, Xellia Pharmaceuticals Ltd, Zagreb, Croatia; Mr F. Mekete, US Pharmacopoeial Convention, Addis Ababa, Ethiopia; Professor V. Merino Sanjuán, Facultad de Farmacia, Valencia, Spain; Dr U. Meyer, Head of Knowledge Management Strategy, Boehringer Ingelheim, Frankfurt, Germany; Ms A. Mdlophane, South African Nuclear Energy Corporation, Pretoria, South Africa; Dr S. Mielcarek, Good Manufacturing Practice Inspector, Chief Pharmaceutical Inspectorate, Warsaw, Poland; Ms S. Migliari, Azienda Ospedaliero – Universitaria di Parma, Parma, Italy; Ms R.K. Miller, Director of Regulatory Affairs, Parenteral Drug Association, Bethesda (MD), United States of America; Mr J. Miller, Assistant Director Scientific Affairs, Parenteral Drug

Association, Bethesda (MD), United States of America; Dr J.H.McB. Miller, Ayr, Scotland; Ms. Mogatle, United Nations Population Fund, UN City, Copenhagen, Denmark; Dr J.A. Molzon, Bethesda (MD), United States of America; Dr K. Moore, Manager, Pharmacopeial Harmonization, US Pharmacopeia, Rockville (MD), United States of America; Ms T. Moore, Medicines and Healthcare Products Regulatory Agency, Good Manufacturing Practice Inspector, London, United Kingdom; Dr P. Moretti, Health Canada, Ottawa, Canada; Mr L. Moura, Brazilian Health Surveillance Agency, Brasília, Brazil; Ms C. Munyimba-Yeta, Missionpharma, Lusaka, Zambia; Dr C. de la Morena, Spanish Agency of Medicines and Medical Devices, Madrid, Spain; Dr E. Moya, Spanish Agency of Medicines and Medical Devices, Madrid, Spain; Ms A.L. Moyo, Technical Analyst, United Nations Population Fund, Bangkok, Thailand; Mr J. Nageshwar, TTK Healthcare Limited, Chennai, India; Dr N. Nakashima, Senior Director for International Programmes, Associate Centre Director for Asia Training Centre, Pharmaceuticals and Medical Devices Agency, Tokyo, Japan; Dr S. Nazarenko, Estonia Nuclear Medicines Society, Tallinn, Estonia; Mrs D. Nel, South African Health Products Regulatory Authority, Pretoria, South Africa; Ms J. Netterville, Associate Director, AstraZeneca plc, Gaithersburg (MD), United States of America; Dr B. Ning, National Institutes for Food and Drug Control, Beijing, China; Dr J. Norwig, Federal Institute for Drugs and Medical Devices, Bonn, Germany; Mr A. Nyika, Senior Regulatory Officer/Good Manufacturing Practice Inspector, Zazibona Inspections Coordinator, Medicines Control Authority, Harare, Zimbabwe; Mrs A. Ojoo, Technical Specialist, Paediatric Formulations, UNICEF Supply Division, Nordhavn, Copenhagen, Denmark; Dr H. Okuda, Deputy Director-General, National Institute of Health Sciences, Tokyo, Japan; Mr S. Onen, National Drug Authority, Kampala, Uganda; Professor J.J. Sousa, Faculdade de Farmácia, Universidade de Coimbra, Coimbra, Portugal; Mrs L.M. Paleshnuik, LP Inc., Ottawa, Canada; Ms L. Paluck, Fedoruk Centre, University of Saskatchewan, Saskatchewan, Canada; Professor G.M. Pauletti, Associate Dean for Graduate Studies, Gustavus and Henry Pfeiffer Chair, Department of Pharmaceutical and Administrative Sciences, University of Health Sciences and Pharmacy, St Louis College of Pharmacy, St Louis (MI), United States of America; Professor H. Fadda, Professor of Pharmaceutics, College of Pharmacy and Health Sciences, Butler University, Indianapolis, United States of America; Professor J.J. Sousa, Faculdade de Farmácia, Universidade de Coimbra, Coimbra, Portugal; Mr S.T. Pedersen, Senior Director, External Affairs, Quality Intelligence and Inspection, Novo Nordisk A/S, Bagsværd, Denmark; Mr D. Poovan, South African Health Products Regulatory Authority, Pretoria, South Africa; Ms K. Porkaew, Head of GMP Inspectorate Unit, Thai Food and Drug Administration, Ministry of Public Health, Bangkok, Thailand; Dr W. Potter, Stapleford Scientific Services Ltd, Cambridge, United Kingdom; Mr S. Prasad, General Manager Corporation, Quality Control, Akums Drugs and Pharmaceuticals Ltd, New

Delhi, India; Ms S. Pulido, PiSA Farmacéutica, Guadalajara, Mexico; Ms I. Radaljac-Pfeiffer, Xellia Pharmaceuticals Ltd, Zagreb, Croatia; Dr L. Rägo, Secretary-General, Council of International Organizations of Medical Sciences, Geneva, Switzerland; Mr A. Rai, SMB Corporation, Mumbai, India; Mr C. Ranga, Deputy Drugs Controller (I), Central Drugs Standard Control Organization, New Delhi, India; Professor M. Razgallah Khrouf, Directeur de la pharmacie et du médicament au Ministère de la santé, Tunis, Tunisia; Mr P.J. Reddy, Indus Medicare Private Limited, Hyderabad, India; Dr H.K. Remmelt Van Der Werf, European Directorate for the Quality of Medicines and Health Care, Council of Europe, Strasbourg, France; Dr M. Rodrigues Cerqueira, Brazilian Health Surveillance Agency, Brasília, Brazil; Mr R.T. Rukwata, Acting Director-General, Medicines Control Authority, Harare, Zimbabwe; Dr J. Sabartova, Prague, Czechia; Mr H. Sakurai, Specialist for Inspection, Office of Manufacturing/Quality and Compliance, Pharmaceuticals and Medical Devices Agency, Tokyo, Japan; Ms A.A. Santana Puentes, Instituto Nacional de Vigilancia de Medicamentos y Alimentos, Bogotá, Colombia; Dr B. Santoso, Yogyakarta, Indonesia; Dr D. Sato, Chief Management Officer, Pharmaceuticals and Medical Devices Agency, Tokyo, Japan; Dr S. Schwarz, Committee on Radiopharmaceuticals, Society of Nuclear Medicine and Molecular Imaging, Virginia, United States of America; Professor G.K.E. Scriba, Professor, Pharmaceutical Chemistry, Friedrich-Schiller University, Jena, Germany; Serum Institute of India, Pune, India; Ms L. Serwaa, Technical Officer, United Nations Population Fund, Bangkok, Thailand; Dr A. Shukla, Serum Institute of India Pvt. Ltd, Pune, India; Dr G.P. Singh, Senior Scientific Officer, Indian Pharmacopoeia Commission, Ministry of Health and Family Welfare, Ghaziabad, India; Ms J. Skutnik-Wilkinson, Director, Global Regulatory CMC Policy, Intelligence and Knowledge Management, Biogen, Research Triangle Park (NC), United States of America; Dr L. Smallshaw, Co-Chair, European Compliance Academy Foundation Board, European Compliance Academy, Heidelberg, Germany; Mr D. Smith, Principal Scientist, SSI Schaefer Systems SA, Pretoria, South Africa; Dr E. Smith, Committee on Radiopharmaceuticals, Society of Nuclear Medicine and Molecular Imaging, Virginia, United States of America; Mr T. Spooner, Director, Engineering, Amgen Inc., West Greenwich (RI), United States of America; Dr M. Stassen, Stassen Pharmaconsult BV, Bloemendaal, the Netherlands; Dr L. Stoppa, Inspections and Certifications Department, Manufacturing Authorisation Office, Italian Medicines Agency, Rome, Italy; Dr J. Sun, Deputy Director General, Department of Drug and Cosmetics Supervision, China Food and Drug Administration, Beijing, China; Dr D. Sun Cuilian, Deputy Laboratory Director, Pharmaceutical Laboratory, Pharmaceutical Division, Health Sciences Authority, Singapore; Dr P. Svarrer Jakobsen, United Nations Children's Fund, Supply Division, Copenhagen, Denmark; Dr E.L. Testa das Neves, Brazilian Health Surveillance Agency, Brasília, Brazil; Mr M. Thompson, Global Pharmaceutical Project

Director, AstraZeneca, Cambridge, United Kingdom; Dr R. Torano, Pharmacopoeial Technical Expert, GlaxoSmithKline, Barnard Castle, United Kingdom; Dr M. Turner, BioIndustry Association, London, United Kingdom; Ms M. Vallejos, Institute of Public Health, Santiago, Chile; Dr A.J. Van Zyl, George, South Africa; Dr Natalia Volovyk, Deputy Head in the Validation and Reference Standards Department and Quality Management Representative at State Enterprise “Ukrainian Scientific Pharmacopoeial Center for Quality of Medicines”, Kyiv, Ukraine; Ms. K. Volz, General Electric Healthcare, United States of America; Mr W. Von Kluechtzner, United Nations Industrial Development Organization, Vienna, Austria; Mr J. Welink, Medicines Evaluation Board, Utrecht, the Netherlands; Professor A. Wessels, North West University, Potchefstroom, South Africa; Mr K. Wilberforce, Directorate of Laboratory Services, National Drug Authority, Kampala, Uganda; Ms C. Winfield, Senior Director, Regulatory Operations, International Society for Pharmacoepidemiology, Bethesda (MD), United States of America; Mr W. Wulandari, Good Manufacturing Practice Inspector, Indonesian Food and Drug Authority, Jakarta Pusat, Indonesia; Dr Mingzhe Xu, Deputy Director, Institute for Chemical Drug Control, China National Institutes for Food and Drug Control, China; Ms A.A. Zuniga, Instituto Nacional de Vigilancia de Medicamentos y Alimentos, Bogotá, Colombia; Professor Kaouther Zribi, University of Monastir, Tunisia.

References

1. The International Pharmacopoeia, 11th edition. Geneva: World Health Organization; 2022. In press.
2. WHO medicines strategy: revised procedure for updating WHO's Model List of Essential Drugs: report by the Secretariat. In: 109th session of the WHO Executive Board, December 2001. Geneva: World Health Organization; 2002 (<https://apps.who.int/iris/handle/10665/78389>, accessed 30 July 2022).
3. Quality Assurance of Medicines Terminology Database. Geneva: World Health Organization (<https://www.who.int/publications/m/item/quality-assurance-of-medicines-terminology-database>, accessed 30 July 2022).
4. IAEA/WHO guideline on good manufacturing practices for radiopharmaceutical products. In: WHO Expert Committee on Specifications for Pharmaceutical Preparations: fifty-fifth report. WHO Technical Report Series No. 1025, Annex 2. Geneva: World Health Organization; 2020.
5. WHO good manufacturing practices: supplementary guidelines for the manufacture of investigational pharmaceutical products for clinical trials in humans. In: WHO Expert Committee on Specifications for Pharmaceutical Preparations: thirty-fourth report. WHO Technical Report Series No. 863, Annex 7. Geneva: World Health Organization; 1996.
6. WHO guidelines on transfer of technology in pharmaceutical manufacturing. In: WHO Expert Committee on Specifications for Pharmaceutical Preparations: forty-fifth report. WHO Technical Report Series No. 961, Annex 7. Geneva: World Health Organization; 2011.
7. Points to consider for setting the remaining shelf-life of medical products upon delivery. In: WHO Expert Committee on Specifications for Pharmaceutical Preparations: fifty-fourth report. WHO Technical Report Series No. 1025, Annex 8. Geneva: World Health Organization; 2020.
8. Protocol to conduct equilibrium solubility experiments for the purpose of Biopharmaceutics Classification System-based classification of active pharmaceutical ingredients for biowaiver. In: WHO Expert Committee on Specifications for Pharmaceutical Preparations: fifty-third report. WHO Technical Report Series No. 1019, Annex 4. Geneva: World Health Organization; 2019 (<https://apps.who.int/iris/bitstream/handle/10665/312316/9789241210287-eng.pdf>, accessed 31 July 2022).
9. Multisource (generic) pharmaceutical products: guidelines on registration requirements to establish interchangeability. In: WHO Expert Committee on Specifications for Pharmaceutical Preparations: fifty-first report. WHO Technical Report Series No. 1003, Annex 6. Geneva: World Health Organization; 2017.
10. Biopharmaceutics Classification System-based biowaivers: M9. ICH Harmonized Guideline. Brussels: International Conference on Harmonisation of Technical Requirements for Registration of Pharmaceuticals for Human Use; 2019 (https://database.ich.org/sites/default/files/M9_Guideline_Step4_2019_1116.pdf, accessed 31 July 2020).
11. M13: bioequivalence for immediate-release solid oral dosage forms. Final concept paper. Brussels: International Conference on Harmonisation of Technical Requirements for Registration of Pharmaceuticals for Human Use; 2019 (https://database.ich.org/sites/default/files/ICH_M13_Concept_Paper_2020_0710.pdf, accessed 31 July 2022).
12. Quality Assurance and Safety of Medicines Team. The Impact of implementation of ICH guidelines in non-ICH countries: report of a WHO meeting, Geneva, 13–15 September 2001. Geneva: World Health Organization; 2002 (<https://apps.who.int/iris/handle/10665/67272>, accessed 2 May 2022).

13. Procedure for the development of World Health Organization medicines quality assurance guidelines. In: WHO Expert Committee on Specifications for Pharmaceutical Preparations: fifty-third report. WHO Technical Report Series No. 1019, Annex 1. Geneva: World Health Organization; 2019 (<https://www.who.int/publications/m/item/trs1019annex1>, accessed 31 July 2022).
14. Monograph availability of COVID-19 investigated drugs in world pharmacopeias. IMWP Monograph Mapping (https://public.tableau.com/app/profile/emma.huang6254/viz/IMWP_MonographMapping/Dashboard, accessed 31 July 2022).
15. Relevant WHO guidance for SARS-CoV2 COVID-19 treatment: medicines. Geneva: World Health Organization; 2020 (https://www.who.int/docs/default-source/medicines/relevant-who-documents-for-sars-cov-2-from-ecspp-index.pdf?sfvrsn=906e947a_3, accessed 31 July 2022).
16. Frequently asked questions by the manufacturing, trial and testing organizations in connection with some of their constraints faced during the COVID-19 outbreak. Geneva: World Health Organization; 2020 (https://extranet.who.int/pqweb/sites/default/files/documents/Covid-19_Q-A_2020.pdf, accessed 31 July 2022).

Annex 1

Guidelines and guidance texts adopted by the Expert Committee on Specifications for Pharmaceutical Preparations

As recommended by World Health Organization (WHO) partners and donor organizations, a full and updated list of WHO norms and standards for medicines, quality assurance and regulatory guidance texts adopted by the Expert Committee and published in the WHO Technical Report Series (TRS) has been drawn up as follows. The guidelines are published in English as the primary language. In cases where there is a translated version to other WHO Official languages, this is indicated in the column “available languages”: CH: Chinese, EN: English, FR: French, RU: Russian.



List of guidelines and guidance for pharmaceuticals

Category	Guideline	TRS	Annex	Year	Available languages
All guidelines	Procedure for the development of World Health Organization medicines quality assurance guidelines	1019	Annex 1	2019	
Development	Development of paediatric medicines: points to consider in formulation	970	Annex 5	2012	
Development	Pharmaceutical development of multisource (generic) finished pharmaceutical products: points to consider	970	Annex 3	2012	
Distribution	Pharmacy services				
Distribution	Joint FIP/WHO guidelines on good pharmacy practice: standards for quality of pharmacy services	961	Annex 8	2011	
Distribution	Compounding				
Distribution	FIP-WHO technical guidelines: Points to consider in the provision by health-care professionals of children-specific preparations that are not available as authorized products	996	Annex 2	2016	
Distribution	Monitoring				
Distribution/ quality control	Guidelines on the conduct of surveys of the quality of medicines	996	Annex 7	2016	
Distribution	Import & Export Controls				
Distribution	Good trade and distribution practices for pharmaceutical starting materials	996	Annex 6	2016	

Category	Guideline	TRS	Annex	Year	Available languages
Distribution	Import & Export Controls (<i>continued</i>)				
Distribution/ regulatory standards	Guidelines on import procedures for medical products	1019	Annex 5	2019	
Distribution/ regulatory standards	WHO pharmaceutical starting materials certification scheme (SMACS): guidelines on implementation	917	Annex 3	2003	
Distribution/ regulatory standards	Guidelines on the implementation of the WHO certification scheme on the quality of pharmaceutical products moving in international commerce	1033	Annex 9	2021	
Distribution	Procurement				
Distribution	Procedure for assessing the acceptability, in principle, of procurement agencies for use by United Nations agencies	917	Annex 6	2003	
Distribution	Model quality assurance system for procurement agencies	986	Annex 3	2014	EN
Distribution	Système modèle d'assurance de la qualité pour les agences d'approvisionnement	986	Annex 3	2014	FR
Distribution	Примерная система обеспечения качества для закупочных агентств	986	Приложение 3	2014	RU
Distribution	Interagency finished pharmaceutical product questionnaire based on the model quality assurance system for procurement agencies	986	Appendix 6 to Module VI, Annex 3	2014	

Category	Guideline	TRS	Annex	Year	Available languages
Distribution	Procurement (continued)				
Distribution	Assessment tool based on the model quality assurance system for procurement agencies: aide-memoire for inspection	986	Annex 4	2014	EN
Distribution	Système modèle d'assurance de la qualité pour les agences d'approvisionnement: aide-mémoire pour les inspections	986	Annex 4	2014	FR
Distribution	Инструмент оценки на основе примерной системы обеспечения качества для закупочных агентств: памятка для инспекции	986	Приложение 4	2014	RU
Distribution	Storage				
Distribution	Good storage and distribution practices for medical products	1025	Annex 7	2020	
Distribution	Points to consider for setting the remaining shelf-life of medical products upon delivery	1025	Annex 8	2020	
Distribution	Model guidance for the storage and transport of time- and temperature-sensitive pharmaceutical products	961	Annex 9	2011	
Distribution	Technical supplements to Model guidance for the storage and transport of time- and temperature-sensitive pharmaceutical products	992	Annex 5	2015	
Distribution	Technical supplements to WHO Technical Report Series No. 961, 2011: introduction to the technical supplements	992	Annex 5	2015	

Category	Guideline	TRS	Annex	Year	Available languages
Distribution	Storage (continued)				
Distribution	<i>Supplement 1: Selecting sites for storage facilities</i>	992	Annex 5	2015	
Distribution	<i>Supplement 2: Design and procurement of storage facilities</i>	992	Annex 5	2015	
Distribution	<i>Supplement 3: Estimating the capacity of storage facilities</i>	992	Annex 5	2015	
Distribution	<i>Supplement 4: Building security and fire protection</i>	992	Annex 5	2015	
Distribution	<i>Supplement 5: Maintenance of storage facilities</i>	992	Annex 5	2015	
Distribution	<i>Supplement 6: Temperature and humidity monitoring systems for fixed storage areas</i>	992	Annex 5	2015	
Distribution	<i>Supplement 7: Qualification of temperature-controlled storage areas</i>	992	Annex 5	2015	
Distribution	<i>Supplement 8: Temperature mapping of storage areas</i>	992	Annex 5	2015	
Distribution	<i>Supplement 9: Maintenance of refrigeration equipment</i>	992	Annex 5	2015	
Distribution	<i>Supplement 10: Checking the accuracy of temperature control and monitoring devices</i>	992	Annex 5	2015	
Distribution	<i>Supplement 11: Qualification of refrigerated road vehicles</i>	992	Annex 5	2015	
Distribution	<i>Supplement 12: Temperature-controlled transport operations by road and by air</i>	992	Annex 5	2015	
Distribution	<i>Supplement 13: Qualification of shipping containers</i>	992	Annex 5	2015	
Distribution	<i>Supplement 14: Transport route profiling qualification</i>	992	Annex 5	2015	

Category	Guideline	TRS	Annex	Year	Available languages
Distribution	Storage (continued)				
Distribution	<i>Supplement 15: Temperature and humidity monitoring systems for transport operations</i>	992	Annex 5	2015	
Distribution	<i>Supplement 16: Environmental management of refrigeration equipment</i>	992	Annex 5	2015	
Inspection					
Inspection	Guidance on good manufacturing practices: inspection report.	996	Annex 4	2016	
Inspection	Quality management system requirements for national inspectorates	1025	Annex 5	2020	
Inspection	Guidelines on pre-approval inspections	902	Annex 7	2002	
Inspection	Provisional guidelines on the inspection of pharmaceutical manufacturers	823	Annex 2	1992	
Inspection	Guidance on good practices for desk assessment of compliance with good manufacturing practices, good laboratory practices and good clinical practices for medical products regulatory decisions	1010	Annex 9	2018	
Production	WHO good manufacturing practices				
Production	General guidance on hold-time studies	992	Annex 4	2015	
Production	WHO guidelines for drafting a site master file	961	Annex 14	2011	

Category	Guideline	TRS	Annex	Year	Available languages
Production	WHO good manufacturing practices (continued)				
Production	WHO good manufacturing practices for pharmaceutical products: main principles	986	Annex 2	2014	EN
Production	Bonnes pratiques de fabrication de l'OMS des produits pharmaceutiques: Grands principes	986	Annex 2	2014	FR
Production	WHO good manufacturing practices for active pharmaceutical ingredients	957	Annex 2	2010	EN
Production	Bonnes pratiques de fabrication de l'OMS pour les substances actives pharmaceutiques	957	Annex 2	2010	FR
Production	Good manufacturing practices: supplementary guidelines for the manufacture of pharmaceutical excipients	885	Annex 5	1999	
Production	WHO good manufacturing practices for sterile pharmaceutical products	961	Annex 6	2011	
Production	WHO good manufacturing practices for biological products [jointly with the Expert Committee on Biological Standardization]	996	Annex 3	2016	
Production	WHO guidelines on good manufacturing practices for blood establishments [jointly with the Expert Committee on Biological Standardization]	961	Annex 4	2011	
Production	WHO good manufacturing practices for pharmaceutical products containing hazardous substances	957	Annex 3	2010	EN

Category	Guideline	TRS	Annex	Year	Available languages
Production	WHO good manufacturing practices (continued)				
Production	Bonnes pratiques de fabrication de l'OMS pour les produits pharmaceutiques contenant des substances dangereuses	957	Annex 3	2010	FR
Production	Good manufacturing practices: supplementary guidelines for the manufacture of investigational pharmaceutical products for clinical trials in humans	863	Annex 7	1996	
Production	Guidelines on good manufacturing practices for the manufacture of herbal medicines	1010	Annex 2	2018	
Production	WHO guidelines on good herbal processing practices for herbal medicines	1010	Annex 1	2018	
Production/ regulatory standards	International Atomic Energy Agency and World Health Organization guideline on good manufacturing practices for radiopharmaceutical products	1025	Annex 2	2020	
Production	Good manufacturing practices: water for pharmaceutical use	1033	Annex 3	2021	
Production	Production of water for injection by means other than distillation	1025	Annex 3	2020	
Production	Guidelines on heating, ventilation and air-conditioning systems for non-sterile pharmaceutical products [Part 1]	1010	Annex 8	2018	

Category	Guideline	TRS	Annex	Year	Available languages
Production	WHO good manufacturing practices (continued)				
Production	Guidelines on heating, ventilation and air-conditioning systems for non-sterile pharmaceutical products. Part 2: Interpretation of guidelines	1019	Annex 2	2019	
Production	Good manufacturing practices: guidelines on validation	1019	Annex 3	2019	
Production	Points to consider when including health-based exposure limits (HBELs) in cleaning validation	1033	Annex 2	2021	
Production	Risk analysis				
Production/ regulatory standards	WHO guidelines on quality risk management	981	Annex 2	2013	
Production/ inspection	Points to consider for manufacturers and inspectors: environmental aspects of manufacturing for the prevention of antimicrobial resistance	1025	Annex 6	2020	
Production	Technology transfer				
Production	WHO guidelines on transfer of technology in pharmaceutical manufacturing	961	Annex 7	2011	
Production	Data management				
Production/ distribution	Guideline on data integrity	1033	Annex 4	2021	

Category	Guideline	TRS	Annex	Year	Available languages
Quality control	Laboratory guidelines				
Quality control	WHO good practices for pharmaceutical quality control laboratories	957	Annex 1	2010	
Quality control	WHO good practices for pharmaceutical microbiology laboratories	961	Annex 2	2011	
Quality control	Good chromatography practices	1025	Annex 4	2020	
Quality control	WHO guidelines for preparing a laboratory information file	961	Annex 13	2011	
Quality control	Screening tests				
Quality control	Basic tests for drugs: pharmaceutical substances, medicinal plant materials and dosage forms				https://apps.who.int/iris/bitstream/handle/10665/42020/9241545135.pdf?sequence=1
Quality control	Analysis of samples				
Quality control	WHO guidelines for sampling of pharmaceutical products and related materials	929	Annex 4	2005	
Quality control	Considerations for requesting analysis of medicines samples	1010	Annex 3	2018	
Quality control	Model certificate of analysis	1010	Annex 4	2018	
Quality control	WHO guidance on testing of "suspect" falsified medicines	1010	Annex 5	2018	

Category	Guideline	TRS	Annex	Year	Available languages
Quality control	Plant materials				
Quality control	Quality control methods for medicinal plant materials	https://apps.who.int/iris/bitstream/handle/10665/41986/9241545100.pdf?sequence=1			
Quality control	WHO guidelines for selecting marker substances of herbal origin for quality control of herbal medicines	1003	Annex 1	2017	
Quality control	Recommendations for quality requirements when plantderived artemisinin is used as a starting material in the production of antimalarial active pharmaceutical ingredients	992	Annex 6	2015	
Quality control	Pharmacopoeias				
Quality control	Good pharmacopoeial practices	996	Annex 1	2016	
Quality control	Good pharmacopoeial practices: Chapter on monographs for compounded preparations	1010	Annex 6	2018	
Quality control	Good pharmacopoeial practices: Chapter on monographs on herbal medicines	1010	Annex 7	2018	

Category	Guideline	TRS	Annex	Year	Available languages
Quality control	The International Pharmacopoeia and International Reference Standards				
Quality control	<i>The International Pharmacopoeia</i>	https://www.who.int/teams/health-product-policy-and-standards/standards-and-specifications/norms-and-standards-for-pharmaceuticals/pharmacopoeia			
Quality control	Procedure for the elaboration, revision and omission of monographs and other texts for <i>The International Pharmacopoeia</i>	1025	Annex 1	2020	
Quality control	<i>The International Pharmacopoeia</i> : revised concepts and future perspectives	1003	Annex 2	2017	
Quality control	Updating mechanism for the section on radiopharmaceuticals in <i>The International Pharmacopoeia</i>	992	Annex 2	2015	
Quality control	<i>The International Pharmacopoeia</i> – related substances tests: dosage form monographs guidance notes	943	Annex 1	2007	
Quality control	WHO International Chemical Reference Substances (ICRS): purposes and use	https://www.edqm.eu/en/WHO-ICRS-Reference-Substances-1393.html			
Quality control	Release procedure for International Chemical Reference Substances	981	Annex 1	2013	
Quality control	General guidelines for the establishment, maintenance and distribution of chemical reference substances	943	Annex 3	2007	
Quality control	Recommendations on risk of transmitting animal spongiform encephalopathy agents via medicinal products	908	Annex 1	2003	

Category	Guideline	TRS	Annex	Year	Available languages
Regulatory standards	Stability				
Regulatory standards	Stability testing of active pharmaceutical ingredients and finished pharmaceutical products	1010	Annex 10	2018	
Regulatory standards	Stability testing of active pharmaceutical ingredients and finished pharmaceutical products: Stability conditions for WHO Member States by region: (update of March 2021)				https://cdn.who.int/media/docs/default-source/medicines/norms-and-standards/guidelines/regulatory-standards/trs953-annex2-appendix1-stability-conditions-table-2018.pdf?sfvrsn=74032aec_12&download=true
Regulatory standards	Clinical trials				
Regulatory standards	Guidelines for good clinical practice (GCP) for trials on pharmaceutical products	850	Annex 3	1995	
Regulatory standards	Interchangeability				
Regulatory standards	Multisource (generic) pharmaceutical products: guidelines on registration requirements to establish interchangeability	1003	Annex 6	2017	
Regulatory standards	WHO "Biowaiver List": proposal to waive in vivo bioequivalence requirements for <i>WHO Model List of Essential Medicines</i> immediate-release, solid oral dosage forms	1025	Annex 12	2020	
Regulatory standards	WHO "Biowaiver List": proposal to waive in vivo bioequivalence requirements for <i>WHO Model List of Essential Medicines</i> immediate-release, solid oral dosage forms	1033	Annex 8	2021	

Category	Guideline	TRS	Annex	Year	Available languages
Regulatory standards	Interchangeability (continued)				
Regulatory standards	Protocol to conduct equilibrium solubility experiments for the purpose of Biopharmaceutics Classification System-based classification of active pharmaceutical ingredients for biowaiver	1019	Annex 4	2019	
Regulatory standards	Guidance for organizations performing in vivo bioequivalence studies	996	Annex 9	2016	
Regulatory standards	General background notes on the list of international comparator pharmaceutical products	1003	Annex 5	2017	
Regulatory standards	Guidance on the selection of comparator pharmaceutical products for equivalence assessment of interchangeable multisource (generic) products	992	Annex 8	2015	
Regulatory standards	List of international comparator products (September 2016)	https://cdn.who.int/media/docs/default-source/medicines/norms-and-standards/guidelines/regulatory-standards/list-int-comparator-prods-after-public-consult30-9.xlsx?sfvrsn=3c9ec04b_2			
Regulatory standards	Medical devices				
Regulatory standards	WHO Global Model Regulatory Framework for Medical Devices including in vitro diagnostic medical devices	1003	Annex 4	2017	
Regulatory standards	World Health Organization/United Nations Population Fund guidance on conducting post-market surveillance of condoms	1033	Annex 7	2021	

Category	Guideline	TRS	Annex	Year	Available languages
Regulatory standards	Medical devices (continued)				
Regulatory standards	World Health Organization/United Nations Population Fund technical specifications for male latex condoms	1025	Annex 10	2020	
Regulatory standards	World Health Organization/United Nations Population Fund specifications for plain lubricants	1025	Annex 11	2020	
Regulatory standards	World Health Organization/United Nations Population Fund guidance on testing of male latex condoms	1033	Annex 6	2021	
Regulatory standards	World Health Organization/United Nations Population Fund recommendations for condom storage and shipping temperatures	1033	Annex 5	2021	
Regulatory standards	Collaborative procedure				
Regulatory standards/ prequalification	Collaborative procedure between the World Health Organization (WHO) Prequalification Team and national regulatory authorities in the assessment and accelerated national registration of WHO-prequalified pharmaceutical products and vaccines	996	Annex 8	2016	
Regulatory standards	Collaborative procedure in the assessment and accelerated national registration of pharmaceutical products and vaccines approved by stringent regulatory authorities	1010	Annex 11	2018	
Regulatory standards	Good practices of national regulatory authorities in implementing the collaborative registration procedures for medical products	1019	Annex 6	2019	

Category	Guideline	TRS	Annex	Year	Available languages
Regulatory standards	Others				
Regulatory standards	WHO general guidance on variations to multisource pharmaceutical products	996	Annex 10	2016	
Regulatory standards	Good review practices: guidelines for national and regional regulatory authorities	992	Annex 9	2015	
Regulatory standards	Guidelines on submission of documentation for a multisource (generic) finished product: quality part	986	Annex 6	2014	
Regulatory standards/ inspection	WHO guidelines for drafting a site master file	961	Annex 14	2011	
Regulatory standards	Guidelines for the preparation of a contract research organization master file	957	Annex 7	2010	
Regulatory standards	Guidelines on active pharmaceutical ingredient master file procedure	948	Annex 4	2008	
Regulatory standards	International nonproprietary names for biological and biotechnological substances: a review	948	Annex 5	2008	
Regulatory standards	Guidelines for registration of fixed-dose combination medicinal products	929	Annex 5	2005	EN
Regulatory standards	Corrected Chinese version 固定剂量复方制剂注册指导原 Guidelines for registration of fixed-dose combination medicinal products	929	Annex 5	2005	CH

Category	Guideline	TRS	Annex	Year	Available languages
Regulatory standards		Others (continued)			
Regulatory standards/ production	Guidelines on packaging for pharmaceutical products	902	Annex 9	2002	
Regulatory standards	WHO guideline on the implementation of quality management systems for national regulatory authorities	1025	Annex 13	2020	
Regulatory standards	Good reliance practices in the regulation of medical products: high level principles and considerations	1033	Annex 10	2021	
Regulatory standards	Good regulatory practices in the regulation of medical products	1033	Annex 11	2021	
Prequalification					
Prequalification	Procedure for prequalification of pharmaceutical products	961	Annex 10	2011	
Prequalification	Guidelines on submission of documentation for a multisource (generic) finished product. General format: preparation of product dossiers in common technical document format	961	Annex 15	2011	
Prequalification	Guidelines on submission of documentation for a multisource (generic) finished pharmaceutical product for the WHO Prequalification of Medicines Programme: quality part	970	Annex 4	2012	
Prequalification	Procedure for assessing the acceptability, in principle, of active pharmaceutical ingredients for use in pharmaceutical products	953	Annex 4	2009	

Category	Guideline	TRS	Annex	Year	Available languages
Prequalification (<i>continued</i>)					
Prequalification	Guidelines on submission of documentation for prequalification of finished pharmaceutical products approved by stringent regulatory authorities	986	Annex 5	2014	
Prequalification	WHO guidelines on variations to a prequalified product	981	Annex 3	2013	
Prequalification	Guidelines on the requalification of prequalified dossiers	957	Annex 6	2010	
Prequalification	Prequalification of quality control laboratories: procedure for assessing the acceptability, in principle, of quality control laboratories for use by United Nations agencies	1003	Annex 3	2017	
Prequalification	World Health Organization/United Nations Population Fund Prequalification Programme guidance for contraceptive devices: male latex condoms, female condoms and intrauterine devices	1025	Annex 9	2020	

Annex 2

WHO good manufacturing practices for sterile pharmaceutical products

Background

This document is a revision of *WHO good manufacturing practices for sterile pharmaceutical products*, previously published in the WHO Technical Report Series, No. 961, Annex 6, 2011.¹ The revision was done in collaboration with the European Union and the Pharmaceutical Inspection Co-operation Scheme (PIC/S). The harmonized text will benefit the national regulatory authorities and manufacturers and save resources, thus improving patients' access to quality medicines.

Contents

Background	87
Abbreviations	89
1. Introduction and scope	89
2. Principle	90
3. Pharmaceutical quality system	92
4. Premises	94
Barrier technologies	98
Cleanroom and clean air equipment qualification	101
Disinfection 106	
5. Equipment	107
6. Utilities	108
Water systems	109
Steam used as a direct sterilizing agent	111
Gases and vacuum systems	111
Heating and cooling and hydraulic systems	112
7. Personnel	112

¹ WHO good manufacturing practices for sterile pharmaceutical products. In: WHO Expert Committee on Specifications for Pharmaceutical Preparations: forty-fifth report. WHO Technical Report Series No. 961, Annex 6. Geneva: World Health Organization; 2011 (<https://apps.who.int/iris/handle/10665/44079>).

8. Production and specific technologies	116
Terminally sterilized products	116
Aseptic preparation and processing	118
Finishing of sterile products	121
Sterilization	124
Sterilization by heat	127
Moist heat sterilization	127
Dry heat sterilization	129
Sterilization by radiation	131
Sterilization with ethylene oxide	131
Sterilization by filtration of products that cannot be sterilized in their final container	132
Form-fill-seal (FFS)	136
Blow-fill-seal (BFS)	138
Lyophilization	141
Closed systems	143
Single-use systems	144
9. Environmental and process monitoring	146
General	146
Environmental and process monitoring	146
Environmental monitoring: total particle	148
Environmental and personnel monitoring: viable particle	150
Aseptic process simulation	152
10. Quality control	159
Glossary	161
Further reading	169

Abbreviations

APS	aseptic process simulation
BFS	blow-fill-seal
CCS	contamination control strategy
CFU	colony-forming unit
EDI	electrodeionization
FFS	form-fill-seal
GMP	good manufacturing practices
HEPA	high-efficiency particulate air
HVAC	heating, ventilation and air-conditioning
PIC/S	Pharmaceutical Inspection Co-operation Scheme
PQS	pharmaceutical quality system
PUPSIT	pre-use post-sterilization integrity test
RABS	restricted access barrier system
SUS	single-use system
WFI	water for injection

1. Introduction and scope

The manufacture of sterile products covers a wide range of sterile product types (such as active substances, excipients, primary packaging materials and finished dosage forms), packed sizes (single unit and multiple units), processes (from highly automated systems to manual processes) and technologies (for example, biotechnology, small molecule manufacturing and closed systems). This guideline provides general guidance that should be used in the design and control of premises, equipment, utilities, systems and procedures used for the manufacture of all sterile products. The principles of quality risk management should be applied to ensure that microbial, particulate and endotoxin/pyrogen contamination is prevented in the final product.

The principles of quality risk management should be applied in all sections of this document and will not be referred to in specific paragraphs. Where specific limits, frequencies or ranges are reflected, these should be considered as a minimum requirement. They are referred to based on historical regulatory experience where issues that have been identified could impact the safety of products and patients.

The intent of this guideline is to provide guidance for the manufacture of sterile products. Some of the principles and guidance, such as contamination control strategy (CCS), design of premises, cleanroom classification, qualification, validation, monitoring and personnel gowning, may be used to support the manufacture of other products that are not intended to be sterile, such as certain liquids, creams, ointments and low bioburden biological intermediates, where the control and reduction of microbial, particulate and endotoxin/pyrogen contamination are considered important. Where a manufacturer elects to apply guidance in this document to non-sterile products, the manufacturer should clearly document which principles have been applied and acknowledge that compliance with those principles should be demonstrated.

2. Principle

2.1 The manufacture of sterile products is subject to specific requirements in order to minimize risks of microbial, particulate and endotoxin/pyrogen contamination. As a minimum, the following areas should be considered:

- i. Premises, equipment and process should be appropriately designed, qualified and validated and, where applicable, be subjected to ongoing verification according to the relevant sections of the good manufacturing practices (GMP) guide. The use of appropriate technologies (such as restricted access barrier systems (RABS), isolators, robotic systems, rapid/alternative methods and continuous monitoring systems) should be considered to increase the protection of the product from potential sources of endotoxin/pyrogen, particulate and microbial contamination, such as personnel, materials and the surrounding environment, and assist in the rapid detection of potential contaminants in the environment and the product.
- ii. Personnel should have adequate qualifications, experience, and training. They should behave in a manner that ensures the protection of sterile product during the manufacturing, packaging and distribution processes.
- iii. Processes and monitoring systems for sterile product manufacture should be designed, commissioned, qualified, monitored and regularly reviewed by personnel with appropriate process, engineering and microbiological knowledge and experience.
- iv. Raw materials and packaging materials should be adequately controlled and tested for bioburden and endotoxin/pyrogen. These materials should meet their specification and should be suitable for use.

- 2.2 Processes, equipment, facilities and manufacturing activities should be managed in accordance with the principles of quality risk management to provide a proactive means of identifying, scientifically evaluating and controlling potential risks to quality. Where alternative approaches are used, these should be supported by appropriate rationale and scientific justification. Quality risk management principles should cover the appropriate design of the facility, equipment and processes, as well as well designed procedures, and the application of monitoring systems that demonstrates that the design and procedures have been correctly implemented and continue to perform in line with expectations. Monitoring or testing alone does not give assurance of sterility.
- 2.3 A CCS should be implemented across the facility in order to define all critical control points and assess the effectiveness of all the controls (design, procedural, technical and organizational) and monitoring measures employed to manage risks to medicinal product quality. The combined strategy of the CCS should provide robust assurance of contamination prevention. The CCS should be reviewed periodically and, where appropriate, updated to drive continual improvement. Its effectiveness should be reviewed as part of the periodic management review process. Where existing control systems are in place and are appropriately managed, these may not require replacement but should be referenced in the CCS and the associated interactions between systems should be understood.
- 2.4 Contamination control and steps taken to minimize the risk of contamination from microbial, endotoxin/pyrogen and particle sources should include a series of interrelated events and measures. These should be assessed and controlled and their effectiveness monitored individually and collectively.
- 2.5 The development of the CCS requires detailed technical and process knowledge. Potential sources of contamination are attributable to microbial and cellular debris (such as pyrogen or endotoxin) as well as particulate (such as glass and other visible and subvisible particles).

Elements to be considered within a CCS should include:

- i. design of both the entire plant and processes, including the associated documentation;
- ii. premises and equipment;
- iii. personnel;
- iv. utilities;

- v. raw material controls, including in-process controls;
 - vi. product containers and closures;
 - vii. vendor approval, for example key component suppliers, sterilization of components and single-use systems (SUS), and critical service providers;
 - viii. management of outsourced activities and availability and transfer of critical information between parties, for example contract sterilization services;
 - ix. process risk management;
 - x. process validation;
 - xi. validation of sterilization processes;
 - xii. maintenance of equipment, utilities and premises (planned and unplanned maintenance);
 - xiii. cleaning and disinfection;
 - xiv. monitoring systems, including an assessment of the feasibility of the introduction of scientifically sound alternative methods that optimize the detection of environmental contamination;
 - xv. prevention mechanisms, including trend analysis, detailed investigation, root cause determination, corrective and preventive actions, and the need for comprehensive investigational tools;
 - xvi. continuous improvement.
- 2.6 The CCS should consider all aspects of contamination control, with ongoing and periodic review resulting in updates within the pharmaceutical quality system as appropriate. Changes to the systems in place should be assessed for any impact on the CCS before and after implementation.
- 2.7 The manufacturer should take all necessary steps and precautions to ensure the sterility of the products manufactured. Sole reliance for sterility or other quality aspects should not be placed on any terminal process or finished product testing.

3. Pharmaceutical quality system

- 3.1 The manufacturer's pharmaceutical quality system (PQS) should encompass and address the specific requirements of sterile product manufacture and ensure that all activities are effectively controlled so as to minimize the risk of microbial, particulate and endotoxin/pyrogen contamination. In addition to the PQS requirements detailed in the main text of the *WHO*

*good manufacturing principles for pharmaceutical products: main principles,*² the PQS for sterile product manufacture should also ensure that:

- i. An effective risk management system is integrated into all areas of the product life cycle with the aim of minimizing contamination and ensuring the quality of sterile products manufactured.
- ii. The manufacturer has sufficient knowledge and expertise in relation to the products manufactured and the equipment, engineering and manufacturing methods employed that may have an impact on product quality.
- iii. Root cause analysis of failures, including of procedure, process or equipment, is performed in such a way that the risk to product is correctly identified and understood, while ensuring that appropriate corrective and preventive actions are implemented.
- iv. Risk management is applied in the development and maintenance of the CCS to identify, assess, reduce (or eliminate where possible) and control contamination risks. Risk management should be documented and should include the rationale for decisions taken in relation to risk reduction and acceptance of residual risk.
- v. Senior management should effectively oversee the state of control throughout the facility and product life cycle. Risk management outcomes should be reviewed regularly as part of ongoing quality management, during change, in the event of a significant emerging problem, and during the periodic product quality review.
- vi. Processes associated with the finishing, storage and transport of sterile products should not compromise the quality of the product. Aspects that should be considered include container integrity, risks of contamination, and avoidance of degradation by ensuring that products are stored and maintained in accordance with the registered storage conditions.
- vii. Persons responsible for the certification or release of sterile products should have appropriate access to manufacturing and quality information and possess adequate knowledge and experience in the manufacture of sterile products and the associated critical quality attributes. This is in order to allow such persons to determine whether the sterile products have been manufactured in accordance with the registered specifications and approved process, and are of the required quality.

² Annex 2 of WHO Expert Committee on Specifications for Pharmaceutical Preparations: forty-eighth report. WHO Technical Report Series No. 986. Geneva: World Health Organization; 2014.

- 3.2 All non-conformities, such as sterility test failures, environmental monitoring excursions or deviations from established procedures, should be adequately investigated before certification or release of the batch. The investigation should determine the potential impact upon process and product quality and whether any other processes or batches are potentially impacted. The reason for including or excluding a product or batch from the scope of the investigation should be clearly justified and recorded.

4. Premises

- 4.1 The manufacture of sterile products should be carried out in appropriate cleanrooms, entry to which should be through change rooms that act as airlocks. Cleanrooms and change rooms should be maintained at an appropriate cleanliness standard and supplied with air that has passed through filters of an appropriate efficiency. Controls and monitoring should be scientifically justified and should effectively evaluate the state of environmental conditions of cleanrooms, airlocks and pass-through hatches.
- 4.2 The various operations of component preparation, product preparation and filling should be carried out with appropriate technical and operational separation measures within the cleanroom or facility to prevent mix-up and contamination.
- 4.3 RABS or isolators may be beneficial in assuring required conditions and minimizing microbial contamination associated with direct human interventions in the critical zone. Their use should be documented in the CCS. Any alternative approaches to the use of RABS or isolators should be justified.
- 4.4 Four grades of cleanrooms or zones are normally used for the manufacture of sterile products.

Grade A. This is the critical zone for high-risk operations (for example, aseptic processing line, filling zone, stopper bowl, open primary packaging, or for making aseptic connections under the protection of first air). Normally, such conditions are provided by a localized airflow protection, such as unidirectional airflow work stations within RABS or isolators. The maintenance of unidirectional airflow should be demonstrated and qualified across the whole of the grade A area. Direct intervention (for example, without the protection of barrier and glove port technology) into the grade A area by operators should be minimized by premises, equipment, process and procedural design.

Grade B. For aseptic preparation and filling, this is the background cleanroom for grade A (where it is not an isolator). Where applicable, air pressure differential between grade B and an adjacent area should be continuously monitored. Cleanrooms of lower grade than grade B can be considered where isolator technology is used (refer to paragraph 4.20).

Grades C and D. These are cleanrooms used for carrying out less critical stages in the manufacture of aseptically filled sterile products or as a background for isolators. They can also be used for the preparation or filling of terminally sterilized products (see section 8 for specific details on terminal sterilization activities).

- 4.5 In cleanrooms and critical zones, all exposed surfaces should be smooth, impervious and unbroken in order to minimize the shedding or accumulation of particles or microorganisms.
- 4.6 To reduce accumulation of dust and to facilitate cleaning, there should be no recesses that are difficult to clean effectively. Projecting ledges, shelves, cupboards and equipment should be kept to a minimum. Doors should be designed to avoid recesses that cannot be cleaned. Sliding doors may be undesirable for this reason.
- 4.7 Materials used in cleanrooms, both in the construction of the room and for items used within the room, should be selected to minimize generation of particles. These should permit the repeated application of cleaning, disinfecting and sporicidal agents where used.
- 4.8 Ceilings should be designed and sealed to prevent contamination from the space above them.
- 4.9 Sinks and drains should be prohibited in the grade A and B areas. In other cleanrooms, air breaks should be fitted between the machine or sink and the drains. Floor drains in lower-grade cleanrooms should be fitted with traps or water seals designed to prevent backflow and should be regularly cleaned, disinfected and maintained.
- 4.10 The transfer of equipment and materials into and out of the cleanrooms and critical zones is one of the greatest potential sources of contamination. Any activities with the potential to compromise the cleanliness of cleanrooms or the critical zone should be assessed, and if they cannot be eliminated appropriate controls should be implemented.
- 4.11 The transfer of materials, equipment and components into the grade A or B areas should be carried out via a unidirectional process. Where possible, items should be sterilized and passed into these areas through

double-ended sterilizers (for example, through a double-door autoclave or depyrogenation oven or tunnel) sealed into the wall. Where sterilization upon transfer of the items is not possible, a procedure that achieves the same objective of not introducing contamination should be validated and implemented (for example, using an effective transfer disinfection process, rapid transfer systems or ports for isolators, or, for gaseous or liquid materials, a bacteria-retentive filter). The removal of items from the grade A and B areas (such as materials, waste and environmental samples) should be carried out via a separate unidirectional process. If this is not possible, time-based separation of movement (incoming or exiting material) by procedure should be considered and controls applied to avoid potential contamination of incoming items.

4.12 Airlocks should be designed and used to provide physical separation and to minimize microbial and particle contamination of the different areas, and should be present for material and personnel moving between different grades. Wherever possible, airlocks used for personnel movement should be separated from those used for material movement. Where this is not practical, time-based separation of movement (personnel or material) by procedure should be considered. Airlocks should be effectively flushed with filtered air to ensure that the grade of the cleanroom is maintained. The final airlock should, in the at rest state, be of the same cleanliness grade (viable and total particle) as the cleanroom into which it leads. The use of separate change rooms for entering and leaving the grade B area is desirable. Where this is not practical, time-based separation of activities (inward or outward) by procedure should be considered. Where the CCS indicates that the risk of contamination is high, separate change rooms for entering and leaving production areas should be used. Airlocks should be designed as follows:

- i. Personnel airlocks: areas of increasing cleanliness used for entry of personnel (for example, from the grade D area to the grade C area to the grade B area). In general, handwashing facilities should be provided only in the first change room and should not be present in change rooms directly accessing the grade B area.
- ii. Material airlocks: used for materials and equipment transfer.
 - Only materials and equipment that have been included on an approved list and assessed during validation of the transfer process should be transferred into the grade A or B areas via an airlock or pass-through hatch. Equipment and materials intended for use in the grade A area should be protected when transiting through the grade B area. Any unapproved items that require transfer should be preapproved as an exception. Appropriate risk assessment and

mitigation measures should be applied and recorded as per the manufacturer's CCS and should include a specific disinfection and monitoring programme approved by quality assurance.

- Pass-through hatches should be designed to protect the higher-grade environment, for example by effective flushing with active filtered air supply of appropriate grade in accordance with the CCS.
- The movement of material or equipment from lower-grade or unclassified areas to higher-grade clean areas should be subject to cleaning and disinfection commensurate with the risk and in line with the CCS.

4.13 For pass-through hatches and airlocks (for material and personnel), the entry and exit doors should not be opened simultaneously. For airlocks leading to the grade A and B areas, an interlocking system should be used. For airlocks leading to grade C and D areas, a visual or audible warning system should be operated as a minimum. Where required to maintain area segregation, a time delay between the closing and opening of interlocked doors should be established and validated.

4.14 Cleanrooms should be supplied with a filtered air supply that maintains a positive pressure and an airflow relative to the background environment of a lower grade under all operational conditions and should flush the area effectively. Adjacent rooms of different grades should have an air pressure differential of a minimum of 10 pascals (guidance value). Particular attention should be paid to the protection of the critical zone. The recommendations regarding air supplies and air pressures may need to be modified where it is necessary to contain certain materials (such as pathogenic, highly toxic or radioactive products or live viral or bacterial materials). The modification may include positively or negatively pressurized airlocks that prevent the hazardous material from contaminating surrounding areas. Decontamination (for example, of the cleanrooms and the heating, ventilation and air-conditioning (HVAC) systems) and the treatment of air leaving a clean area may be necessary for some operations. Where containment requires air to flow into a critical zone, the source of the air should be an area of the same or higher grade.

4.15 Airflow visualization studies should demonstrate airflow patterns within cleanrooms and zones proving that there is no ingress from lower-grade to higher-grade areas and that air does not flow from less clean areas (such as the floor) or over operators or equipment, thus transferring contaminants to the higher-grade areas. Where unidirectional airflow is required, visualization studies should be performed to demonstrate compliance

(refer to paragraphs 4.4 and 4.19). When filled and closed products are transferred to an adjacent cleanroom of a lower grade via a small exit point, airflow visualization studies should demonstrate that there is no ingress from the lower-grade cleanroom to the grade B area. Where air movement is shown to be a contamination risk to the clean area or critical zone, corrective action, such as design improvement, should be implemented. Airflow pattern studies should be performed both at rest and in operation (for example, simulating operator interventions). Video recordings of the airflow patterns should be carried out by following good practices to demonstrate the above. Recordings should be retained. The outcome of the air visualization studies should be documented and taken into consideration when establishing the facility's environmental monitoring programme.

- 4.16 Indicators of air pressure differential should be fitted between cleanrooms and between isolators and their background. Set points and the criticality of air pressure differential should be considered within the CCS. Air pressure differentials identified as critical should be continuously monitored and recorded. A warning system should be in place to instantly indicate and warn operators of any failure in the air supply or reduction of air pressure differential (below set limits for those identified as critical). The warning signal should not be overridden without appropriate assessment and a procedure should be available to outline the steps to be taken when a warning signal is given. Where alarm delays are set, these should be assessed and justified within the CCS. Other air pressure differentials should be monitored and recorded at regular intervals.
- 4.17 Facilities should be designed to permit observation of production activities from outside the grade A and B areas (for example, through the provision of windows or remote cameras with a full view of the area and processes to enable observation and supervision without entry). This requirement should be considered when designing new facilities or during the refurbishment of existing facilities.

Barrier technologies

- 4.18 Isolators and RABS, which are different technologies, and the associated processes, should be designed to provide protection through separation of its grade A environment and the surrounding environment. The hazards introduced from entry or removal of items during processing should be minimized and supported by high-capability transfer technologies or validated systems that effectively prevent contamination and are appropriate for the respective technology.

4.19 The design of the technology and processes used should ensure that appropriate conditions are maintained in the critical zone to protect the exposed product during operations.

- i. Isolators:
 - a. The design of open isolators should ensure grade A conditions with first air protection in the critical zone and unidirectional airflow that sweeps over and away from exposed products during processing.
 - b. The design of closed isolators should ensure grade A conditions with adequate protection for exposed products during processing. Airflow may not be fully unidirectional in closed isolators where simple operations are conducted. However, any turbulent airflow should not increase the risk of contamination of the exposed product. Where processing lines are included in closed isolators, grade A conditions should be ensured with first air protection in the critical zone and unidirectional airflow that sweeps over and away from exposed products during processing.
 - c. Negative pressure isolators should only be used when containment of the product is considered essential (for example, radiopharmaceutical products) and specialized risk control measures should be applied to ensure the critical zone is not compromised.
- ii. RABS:
 - a. The design of RABS should ensure grade A conditions with unidirectional airflow and first air protection in the critical zone. A positive airflow from the critical zone to the supporting background environment should be maintained.

4.20 The background environment for isolators and RABS should ensure that the risk of transfer of contamination is minimized.

- i. Isolators:
 - a. The background environment for open isolators should generally correspond to a minimum of grade C. The background for closed isolators should correspond to a minimum of grade D. The decision on the background classification should be based on risk assessment and justified in the CCS.
 - b. Key considerations when performing the risk assessment for the CCS of an isolator should include the biodecontamination programme, the extent of automation, the impact of glove

manipulations that may potentially compromise first air protection of critical process points, the impact of potential loss of barrier or glove integrity, transfer mechanisms used, and activities such as set-up or maintenance that may require the doors to be opened prior to the final biodecontamination of the isolator. Where additional process risks are identified, a higher grade of background should be considered unless appropriately justified in the CCS.

- c. Airflow pattern studies should be performed at the interfaces of open isolators to demonstrate the absence of air ingress.
- ii. RABS:
 - a. The background environment for RABS used for aseptic processing should correspond to a minimum of grade B, and airflow pattern studies should be performed to demonstrate the absence of air ingress during interventions, including door openings if applicable.
- 4.21 The materials used for glove systems (for both isolators and RABS) should be demonstrated to have appropriate mechanical and chemical resistance. The frequency of glove replacement should be defined within the CCS.
- i. Isolators:
 - a. For isolators, leak testing of the glove system should be performed using a methodology demonstrated to be suitable for the task and criticality. The testing should be performed at defined intervals. Generally, glove integrity testing should be performed at a minimum frequency at the beginning and end of each batch or campaign. Additional glove integrity testing may be necessary, depending on the validated campaign length. Glove integrity monitoring should include a visual inspection associated with each use and following any manipulation that may affect the integrity of the system.
 - b. For manual aseptic processing activities where single unit or small batch sizes are produced, the frequency of integrity verification may be based on other criteria, such as the beginning and end of each manufacturing session.
 - c. Integrity and leak testing of isolator systems should be performed at defined intervals.

- ii. RABS:
 - a. For RABS, gloves used in the grade A area should be sterilized before installation and sterilized or effectively biodecontaminated by a validated method prior to each manufacturing campaign. If exposed to the background environment during operation, disinfection using an approved methodology following each exposure should be completed. Gloves should be visually examined with each use, and integrity testing should be performed at periodic intervals.

4.22 Decontamination methods (cleaning and biodecontamination, and where applicable inactivation for biological materials) should be appropriately defined and controlled. The cleaning process prior to the biodecontamination step is essential, as any residues that remain may inhibit the effectiveness of the decontamination process. Evidence should also be available to demonstrate that the cleaning and biodecontamination agents used do not have any adverse impact on the product produced within the RABS or isolator.

- i. Isolators:
 - a. The biodecontamination process of the interior should be automated, validated and controlled within defined cycle parameters and should include a sporicidal agent in a suitable form (for example, gaseous or vaporized form). Gloves should be appropriately extended with fingers separated to ensure overall contact with the agent. Methods used (cleaning and sporicidal biodecontamination) should render the interior surfaces and critical zone of the isolator free from viable microorganisms.
- ii. RABS:
 - a. The sporicidal disinfection should include the routine application of a sporicidal agent using a method that has been validated and demonstrated to effectively include all areas of the interior surfaces and ensure a suitable environment for aseptic processing.

Cleanroom and clean air equipment qualification

4.23 Cleanrooms and clean air equipment used for the manufacture of sterile products, such as unidirectional airflow units, RABS and isolators, should be qualified. Each manufacturing operation requires an appropriate environmental cleanliness level in the operational state in order to minimize the risk of contamination of the materials or product being

handled. The appropriate cleanliness levels in the at rest and operational states should be maintained.

- 4.24 Cleanrooms and clean air equipment should be qualified using methodology in accordance with the requirements of the WHO *Good manufacturing practices: guideline on validation*.³ Cleanroom qualification (including classification) should be clearly differentiated from operational environmental monitoring.
- 4.25 Cleanroom and clean air equipment qualification is the overall process of confirming the level of compliance of a classified cleanroom or clean air equipment. As part of the qualification requirements, the qualification of cleanrooms and clean air equipment should include (where relevant to the design and operation of the installation):
- i. installed filter leakage test and filter integrity testing
 - ii. airflow tests – volume and velocity
 - iii. air pressure differential test
 - iv. airflow direction test and air flow visualization test
 - v. microbial airborne and surface contamination test
 - vi. temperature measurement test
 - vii. relative humidity test
 - viii. recovery test
 - ix. containment leakage test.

Reference for the qualification of the cleanrooms and clean air equipment can be found in the *WHO Guidelines on heating, ventilation and air-conditioning systems for non-sterile pharmaceutical products*⁴ and ISO 14644 series of standards.

- 4.26 Cleanroom classification is part of the cleanroom qualification and is a method of confirming the level of air cleanliness against a specification for a cleanroom or clean air equipment by measuring the particle concentration. Classification activities should be scheduled and performed in order to avoid any impact on process or product quality. For example,

³ Annex 3 of WHO Expert Committee on Specifications for Pharmaceutical Preparations: fifty-third report. WHO Technical Report Series No. 1019. Geneva: World Health Organization; 2019.

⁴ Annex 8 of WHO Expert Committee on Specifications for Pharmaceutical Preparations: fifty-second report. WHO Technical Report Series No. 1010. Geneva: World Health Organization; 2018.

initial classification should be performed during simulated operations and reclassification performed during simulated operations or during aseptic process simulation (APS).

- 4.27 For cleanroom classification, the total of particles equal to or greater than 0.5 and 5 μm should be measured. Maximum permitted particle concentration limits are specified in Table. 1.

Table. 1

Maximum permitted total particle concentration for classification

Grade	Maximum limits for total particle $\geq 0.5 \mu\text{m}/\text{m}^3$		Maximum limits for total particle $\geq 5 \mu\text{m}/\text{m}^3$	
	At rest	In operation	At rest	In operation
A	3 520	3 520	Not specified ^a	Not specified ^a
B	3 520	352 000	Not specified ^a	2 930
C	352 000	3 520 000	2 930	29 300
D	3 520 000	Not predetermined ^b	29 300	Not predetermined ^b

^a Classification including 5 μm particles may be considered where indicated by the CCS or historical trends.

^b For grade D, in operation limits are not predetermined. The manufacturer should establish in operation limits based on a risk assessment and routine data where applicable.

- 4.28 For classification of the cleanroom, the minimum number of sampling locations and their positioning can be found in ISO 14644 Part 1. For the aseptic processing area and the background environment (the grade A and B areas, respectively) additional sample locations should be considered, and all critical processing areas, such as the point of fill and container closure feeder bowls, should be evaluated. Critical processing locations should be determined by documented risk assessment and knowledge of the process and operations to be performed in the area.

- 4.29 Cleanroom classification should be carried out in the at rest and in operation states.

- i. The definition of the at rest state is the condition whereby the installation of all the utilities is complete, including any functioning HVAC, with the main manufacturing equipment installed as specified but not operating and without personnel present in the room.

- ii. The definition of the in operation state is the condition whereby the installation of the cleanroom is complete, the HVAC system fully operational, and the equipment is installed and functioning in the manufacturer's defined operating mode, with the maximum number of personnel present performing or simulating routine operational work.
 - iii. The total particle limits given in Table.1 above for the at rest state should be achieved after a clean-up period upon completion of operations and line clearance or cleaning activities. The clean-up period (guidance value of less than 20 minutes) should be determined during the qualification of the rooms, documented, and adhered to in procedures to reinstate a qualified state of cleanliness if disrupted during operation.
- 4.30 The speed of air supplied by unidirectional airflow systems should be clearly justified in the qualification protocol, including the location for air speed measurement. Air speed should be designed, measured and maintained to ensure that appropriate unidirectional air movement provides protection of the product and open components at the working position (for example, where high-risk operations occur and where product or components are exposed). Unidirectional airflow systems should provide a homogeneous air speed in a range of 0.36–0.54 metres per second (m/s) (guidance value) at the working level, unless otherwise scientifically justified in the CCS. Airflow visualization studies should correlate with the air speed measurement.
- 4.31 The microbial contamination level of the cleanrooms should be determined as part of the cleanroom qualification. The number of sampling locations should be based on a documented risk assessment and the results obtained from room classification, air visualization studies, and knowledge of the process and operations to be performed in the area. The maximum limits for microbial contamination during qualification for each grade are given in Table.2. Qualification should include both at rest and operational states.

Table. 2
Maximum permitted microbial contamination level during qualification

Grade	Air sample CFU/m ³	Settle plates (diameter 90 mm) CFU/4 hours ^a	Contact plates (diameter 55 mm) CFU/plate
A		No growth	
B	10	5	5
C	100	50	25
D	200	100	50

CFU = colony-forming unit.

^a Settle plates should be exposed for the duration of operations and changed as required, or after a maximum of 4 hours. Exposure time should be based on recovery studies and should not allow desiccation of the media used.

Note 1: All methods indicated for a specific grade in the table should be used for qualifying the area of that specific grade. If one of the methods tabulated is not used, or alternative methods are used, the approach taken should be appropriately justified.

Note 2: Limits are applied using CFU throughout the document. If different or new technologies are used that present results in a manner different from CFU, the manufacturer should scientifically justify the limits applied and where possible correlate them to CFU.

Note 3: For the qualification of personnel gowning, the limits given for contact plates and glove prints in Table.6 should apply.

Note 4: Sampling methods should not pose a risk of contamination to the manufacturing operations.

4.32 The requalification of cleanrooms and clean air equipment should be carried out periodically following defined procedures. The requalification should include, at a minimum, the following:

- i. cleanroom classification (total particle concentration);
- ii. integrity test of final filters;
- iii. airflow volume measurement;
- iv. verification of air pressure difference between rooms;
- v. air velocity test. Note: For grade B, C and D, the air velocity test should be performed according to a risk assessment documented as part of the CCS. It is however, required for filling zones supplied with unidirectional airflow (for example, when filling terminally sterilized products or background to grade A and RABS). For grades with non-unidirectional airflow, a recovery test should replace velocity testing.

The maximum time interval for requalification of grade A and B areas is 6 months.

The maximum time interval for requalification of grade C and D areas is 12 months.

Appropriate requalification consisting of at least the above tests should also be carried out following completion of remedial action implemented to rectify an out of compliance equipment or facility condition or after changes to equipment, facility or processes, as appropriate. The significance of a change requiring requalification should be determined through the change management process. Examples of changes requiring requalification include the following:

- i. interruption of air movement that affects the operation of the installation;
- ii. change in the design of the cleanroom or of the operational setting parameters of the HVAC system;
- iii. special maintenance that affects the operation of the installation (such as a change of final filters).

Disinfection

- 4.33 The disinfection of cleanrooms is particularly important. They should be cleaned and disinfected thoroughly in accordance with a written programme. For disinfection to be effective, cleaning to remove surface contamination should be performed prior to disinfection. Cleaning programmes should effectively remove disinfectant residues. More than one type of disinfecting agent should be employed to ensure that where they have different modes of action, their combined usage is effective against bacteria and fungi. Disinfection should include the periodic use of a sporicidal agent. Monitoring should be undertaken regularly in order to assess the effectiveness of the disinfection programme and to detect changes in types of microbial flora (for example, organisms resistant to the disinfection regime currently in use).
- 4.34 The disinfection process should be validated. Validation studies should demonstrate the suitability and effectiveness of disinfectants in the specific manner in which they are used and on the type of surface material, or representative material if justified, and should support the in-use expiry periods of prepared solutions.
- 4.35 Disinfectants and detergents used in grade A and B areas should be sterile. Disinfectants used in grade C and D areas may also be required to be sterile where determined in the CCS. Where the disinfectants and detergents are diluted or prepared by the sterile product manufacturer,

this should be done in a manner to prevent contamination, and they should be monitored for microbial contamination. Dilutions should be kept in previously cleaned (and sterilized, where applicable) containers and should only be stored for the defined period. If the disinfectants and detergents are supplied ready-made, then results from certificates of analysis or conformance can be accepted, subject to successful completion of the appropriate vendor qualification.

- 4.36 Where fumigation or vapour disinfection (for example, vapour phase hydrogen peroxide) of cleanrooms and associated surfaces is used, the effectiveness of the fumigation agent and dispersion system should be validated.

5. Equipment

- 5.1 A detailed written description of the equipment design should be available (including process and instrumentation diagrams as appropriate). This should form part of the initial qualification documentation and be kept up to date.
- 5.2 Equipment monitoring requirements should be defined in user requirements specifications during early stages of development, and confirmed during qualification. Process and equipment alarm events should be acknowledged and evaluated for trends. The frequency at which alarms are assessed should be based on their criticality (with critical alarms reviewed immediately).
- 5.3 As far as practicable, equipment, fittings and services should be designed and installed so that operations, maintenance, and repairs can be performed outside the cleanroom. If maintenance has to be performed in the cleanroom, and the required standards of cleanliness or asepsis cannot be maintained, then precautions such as restricting access to the work area to specified personnel and generation of clearly defined work protocols and maintenance procedures should be considered. Additional cleaning, disinfection and environmental monitoring should also be performed where appropriate. If sterilization of equipment is required, it should be carried out, wherever possible, after complete reassembly.
- 5.4 The validated cleaning procedure should be able to:
- i. remove any residue or debris that would detrimentally impact the effectiveness of the disinfecting agent used;
 - ii. minimize chemical, microbial and particulate contamination of the product during the process and prior to disinfection.

- 5.5 For aseptic processes, direct and indirect product contact parts should be sterilized. Direct product contact parts are those that the product passes through, such as filling needles or pumps. Indirect product contact parts are equipment parts that do not contact the product but may come into contact with other sterilized surfaces, the sterility of which is critical to the overall product sterility (for example, sterilized items such as stopper bowls and guides, and sterilized components).
- 5.6 All equipment, such as sterilizers, air handling systems (including air filtration systems) and water systems, should be subject to qualification, monitoring and planned maintenance. Upon completion of maintenance or repairs, their return to use should be approved.
- 5.7 Where unplanned maintenance of equipment critical to the sterility of the product is to be carried out, an assessment of the potential impact to the sterility of the product should be performed and recorded.
- 5.8 A conveyor belt should not pass through a partition between a grade A or B area and a processing area of lower air cleanliness, unless the belt itself is continually sterilized (for example, in a sterilizing tunnel).
- 5.9 Particle counters, including sampling tubing, should be qualified. The manufacturer's recommended specifications should be considered for tube diameter and bend radii. Tube length should typically be no longer than 1 m unless justified, and the number of bends should be minimized. Portable particle counters with a short length of sample tubing should be used for classification purposes. Isokinetic sampling heads should be used in unidirectional airflow systems. They should be oriented appropriately and positioned as close as possible to the critical location to ensure that samples are representative.

6. Utilities

- 6.1 The nature and extent of controls applied to utility systems should be commensurate with the risk to product quality associated with the utility. The impact should be determined through risk assessment and documented as part of the CCS.
- 6.2 In general, higher-risk utilities are those that:
- i. directly contact product (for example, water for washing and rinsing, gases and steam for sterilization);
 - ii. contact materials that will ultimately become part of the product;

- iii. contact surfaces that come into contact with the product;
 - iv. otherwise directly impact the product.
- 6.3 Utilities should be designed, installed, qualified, operated, maintained and monitored in a manner that ensures that the utility system functions as expected.
- 6.4 Results for critical parameters and critical quality attributes of high-risk utilities should be subject to regular trend analysis to ensure that system capabilities remain appropriate.
- 6.5 Records of utility system installation should be maintained throughout the system's life cycle. Such records should include current drawings and schematic diagrams, construction material lists and system specifications. Typically, important information includes attributes such as:
- i. pipeline flow direction, slope, diameter and length
 - ii. tank and vessel details
 - iii. valves, filters, drains, sampling points and user points.
- 6.6 Pipes, ducts and other utilities should not be present in cleanrooms. If unavoidable, then they should be installed so that they do not create recesses, unsealed openings and surfaces that are difficult to clean. Installation should allow cleaning and disinfection of outer surface of the pipes.

Water systems

- 6.7 Note: Refer to WHO *Good manufacturing practices: water for pharmaceutical use* (Annex 3, WHO Technical Report Series 1033, 2021) and *Production of water for injection by means other than distillation* (Annex 3, WHO Technical Report Series 1025, 2020) for the main principles on water systems; and monographs for water for injection published in *The International Pharmacopoeia*, as well as various national pharmacopoeias for the minimum requirements for the quality of water for injection. Water treatment plant and distribution systems should be designed, constructed, installed, commissioned, qualified, monitored and maintained to prevent microbiological contamination and to ensure a reliable source of water of an appropriate quality. Measures should be taken to minimize the risk of presence of particulates, microbial contamination and proliferation, and endotoxin/pyrogen (for example, by sloping pipes to provide complete drainage and the avoidance of dead legs). Where filters are included in the system, special attention should be given to their monitoring and maintenance. Water produced should comply with the current monograph of the relevant pharmacopoeia.

- 6.8 Water systems should be qualified and validated to maintain the appropriate levels of physical, chemical and microbial control, taking the effect of seasonal variation into account.
- 6.9 Water flow should remain turbulent through the pipes in water distribution systems to minimize the risk of microbial adhesion and subsequent biofilm formation. The flow rate should be verified during qualification and be routinely monitored.
- 6.10 Water for injection (WFI) should be produced from water meeting specifications that have been defined during the qualification process, stored and distributed in a manner that minimizes the risk of microbial growth (for example, by constant circulation at a temperature above 70 °C). WFI should be produced by distillation or other suitable means. These may include reverse osmosis coupled with other appropriate techniques such as electrodeionization (EDI), ultrafiltration or nanofiltration.
- 6.11 Where storage tanks for water for pharmaceutical use and WFI are equipped with hydrophobic bacteria-retentive vent filters, the filters should not be a source of contamination and the integrity of the filter should be tested before installation and after use. Controls should be in place to prevent condensation formation on the filter (for example, heating).
- 6.12 To minimize the risk of biofilm formation, sterilization, sanitization, disinfection or regeneration, as appropriate, of water systems should be carried out according to a predetermined schedule and as a remedial action following out-of-limit or specification results. Disinfection of a water system with chemicals should be followed by a validated rinsing or flushing procedure. Water should be tested after disinfection or regeneration. Chemical testing results should be approved before the water system is returned to use and microbiological (endotoxin, where appropriate) results verified to be within specification and approved before batches manufactured using water from the system are considered for certification or release.
- 6.13 Regular ongoing chemical and microbial monitoring of water systems should be performed to ensure that the water continues to meet compendial expectations. Alert levels should be based on the initial qualification data and thereafter periodically reassessed on data obtained during subsequent requalifications, routine monitoring and investigations. The review of ongoing monitoring data should be carried out to identify any adverse trend in system performance. Sampling programmes should reflect the requirements of the CCS and should include all outlets and points of use, at a specified interval, to ensure that representative water

samples are obtained for analysis on a regular basis. Sample plans should be based on the qualification data, should consider the potential worst-case sampling locations and should ensure that at least one representative sample is included every day of the water that is used for manufacturing processes.

- 6.14 Alert level excursions should be documented and reviewed, and include an investigation to determine whether the excursion is a single (isolated) event or if results are indicative of an adverse trend or system deterioration. Each action limit excursion should be investigated to determine the probable root causes and any potential impact on the quality of product and manufacturing processes as a result of the use of the water.
- 6.15 WFI systems should include continuous monitoring systems, for example for total organic carbon and conductivity, as these may give a better indication of overall system performance than discrete sampling. Sensor locations should be based on risk.

Steam used as a direct sterilizing agent

- 6.16 Feed water to a pure steam (clean steam) generator should be appropriately purified. Pure steam generators should be designed, qualified and operated in a manner that ensures that the quality of steam produced meets defined chemical and endotoxin levels.
- 6.17 Steam used as a direct sterilizing agent should be of suitable quality and should not contain additives at a level that could cause contamination of product or equipment. For a generator supplying pure steam used for the direct sterilization of materials or product contact surfaces (such as porous hard-goods autoclave loads), steam condensate should meet the current monograph for WFI of the relevant pharmacopoeia (microbial testing is not mandatory for steam condensate). A suitable sampling schedule should be in place to ensure that the sample for analysis is collected on a regular basis. The sample should be representative of the pure steam. Other aspects of the quality of pure steam used for sterilization should be assessed periodically against parameters. These parameters should include the following (unless otherwise justified): non-condensable gases, dryness value (dryness fraction) and superheat.

Gases and vacuum systems

- 6.18 Gases that come in direct contact with the product or primary container surfaces should be of appropriate chemical, particulate and microbial quality. All relevant parameters, including oil and water content, should be

specified, taking into account the use and type of the gas and the design of the gas generation system, and, where applicable, should comply with the current monograph of the relevant pharmacopoeia or the product quality requirement.

- 6.19 Gases used in aseptic processes should be filtered through a sterilizing grade filter (with a nominal pore size of a maximum of 0.22 μm) at the point of use. Where the filter is used on a batch basis (for example, for filtration of gas used for overlay of aseptically filled products) or as product vessel vent filter, then the filter should be integrity tested and the results reviewed as part of the batch certification and release process. Any transfer pipework or tubing that is located after the final sterilizing grade filter should be sterilized. When gases are used in the process, microbial monitoring of the gas should be performed periodically at the point of use.
- 6.20 Where backflow from vacuum or pressure systems poses a potential risk to the product, there should be a mechanism to prevent backflow when the vacuum or pressure system is shut off.

Heating and cooling and hydraulic systems

- 6.21 Major items of equipment associated with hydraulic, heating and cooling systems should, where possible, be located outside the filling room. There should be appropriate controls to contain any spillage or cross-contamination associated with the system fluids.
- 6.22 Any leaks from these systems that would present a risk to the product should be detectable (for example, using an indication system for leakage).

7. Personnel

- 7.1 The manufacturer should ensure that there is a sufficient number of personnel, appropriately and suitably qualified, trained and experienced in the manufacture and testing of sterile products, and any of the specific manufacturing technologies used in the site's manufacturing operations.
- 7.2 Only the minimum number of personnel required should be present in cleanrooms. The maximum number of operators in cleanrooms should be determined, documented and considered during activities, such as initial qualification and APS, so as not to compromise sterility assurance.
- 7.3 Personnel, including those performing cleaning, maintenance and monitoring and those that access cleanrooms, should receive regular

training and undergo gowning qualification and assessment in disciplines relevant to the correct manufacture of sterile products. This training should include the basic elements of microbiology and hygiene (with a specific focus on cleanroom practices), contamination control, aseptic techniques and the protection of sterile products (for those operators entering the grade B cleanrooms or intervening into grade A), and the potential safety implications for the patient if the product is not sterile. The level of training should be based on the criticality of the function and area in which the personnel are working.

- 7.4 The personnel accessing grade A and B areas should be trained for aseptic gowning and aseptic behaviours. Compliance with aseptic gowning procedures should be confirmed by assessment and periodic reassessment at least annually, and should involve both visual and microbial assessment using monitoring locations such as gloved fingers, forearms, chest and hood (face mask and forehead) (refer to paragraph 9.30 for the expected limits). Unsupervised access to the grade A and grade B areas where aseptic operations are or will be conducted should be restricted to appropriately qualified personnel, who have passed the gowning assessment and have participated in a successful APS.
- 7.5 Unqualified persons should not enter grade B cleanrooms or grade A when in operation. If needed in exceptional cases, manufacturers should establish written procedures outlining the process by which unqualified persons are brought into the grade B and A areas. An authorized person from the manufacturer should supervise the unqualified persons during their activities and should assess the impact of these activities on the cleanliness of the area. Access by these persons should be assessed and recorded in accordance with the PQS.
- 7.6 There should be systems in place for the disqualification of personnel from working in or given unsupervised entry into cleanrooms that is based on specified aspects, including ongoing assessment or identification of an adverse trend from the personnel monitoring programme or implication in a failed APS. Once disqualified, retraining and requalification should be completed before permitting the operator to have any further involvement in aseptic practices. For operators entering grade B cleanrooms or performing intervention into grade A, this requalification should include consideration of participation in a successful APS.
- 7.7 High standards of personal hygiene and cleanliness are essential to prevent excessive shedding or increased risk of introduction of microbial contamination. Personnel involved in the manufacture of sterile products

should be instructed to report any specific health conditions or ailments that may cause the shedding of abnormal numbers or types of contaminants and therefore preclude cleanroom access. Health conditions and actions to be taken with regard to personnel who could be introducing an undue microbial hazard should be provided by the designated competent person and described in procedures.

- 7.8 Personnel who have been engaged in the processing of human or animal tissue materials or of cultures of microorganisms, other than those used in the current manufacturing process, or any activities that may have a negative impact on quality (such as microbial contamination), should not enter clean areas unless clearly defined and effective decontamination and entry procedures have been followed and documented.
- 7.9 Wristwatches, make-up, jewellery, mobile phones and any other non-essential items should not be allowed in clean areas. Electronic devices used in cleanrooms (such as mobile phones and tablets) that are supplied by the manufacturer solely for use in the cleanrooms may be acceptable if suitably designed to permit cleaning and disinfection commensurate with the grade in which they are used. The use and disinfection of such equipment should be included in the CCS.
- 7.10 Cleanroom gowning and handwashing should follow a written procedure designed to minimize contamination of cleanroom clothing or the transfer of contaminants to the clean areas.
- 7.11 The clothing and its quality should be appropriate for the process and the grade of the working area. It should be worn in such a way as to protect the product from contamination. When the type of clothing chosen needs to provide the operator protection from the product, it should not compromise the protection of the product from contamination. Garments should be visually checked for cleanliness and integrity immediately prior to and after gowning. Gown integrity should also be checked upon exit. For sterilized garments and eye coverings, particular attention should be given to ensuring that they have been subject to the sterilization process and are within their specified hold time. The packaging should be visually inspected to ensure its integrity before use. Reusable garments (including eye coverings) should be replaced if damage is identified, and at a set frequency that is determined during qualification studies. The qualification of garments should consider any necessary garment testing requirements, including damage to garments that may not be identified by visual inspection alone.
- 7.12 Clothing should be chosen to limit shedding due to operators' movement.

7.13 A description of typical clothing required for each cleanliness grade is given below.

- i. **Grade B** (including access or interventions into grade A). Appropriate garments that are dedicated for use under a sterilized suit should be worn before gowning (refer to paragraph 7.14). Appropriately sterilized, non-powdered, rubber or plastic gloves should be worn while donning the sterilized garments. Sterile headgear should enclose all hair (including facial hair) and, where separate from the rest of the gown, should be tucked into the neck of the sterile suit. A sterile face mask and sterile eye coverings (such as goggles) should be worn to cover and enclose all facial skin and prevent the shedding of droplets and particles. The appropriate sterilized footwear (such as overboots) should be worn. Trouser legs should be tucked inside the footwear. Garment sleeves should be tucked into a second pair of sterile gloves worn over the pair worn while donning the gown. The protective clothing should minimize shedding of fibres and other particles and retain particles shed by the body. The particle shedding and the particle retention efficiencies of the garments should be assessed during the garment qualification. Garments should be packed and folded in such a way as to allow operators to don the gown without contacting the outer surface of the garment and to prevent the garment from touching the floor.
- ii. **Grade C.** Hair, beards and moustaches should be covered. A single- or two-piece trouser suit gathered at the wrists and with high neck and appropriately disinfected shoes or overshoes should be worn. They should minimize the shedding of fibres and particles.
- iii. **Grade D.** Hair, beards and moustaches should be covered. A general protective suit and appropriately disinfected shoes or overshoes should be worn. The appropriate measures should be taken to avoid any ingress of contaminants from outside the clean area.
- iv. Additional gowning, including gloves and a face mask, may be required in grade C and D areas when performing activities considered to be a contamination risk, as defined by the CCS.

7.14 Cleanroom gowning should be performed in change rooms of an appropriate cleanliness grade to ensure that gown cleanliness is maintained. Outdoor clothing, including socks (other than personal underwear), should not be brought into changing rooms leading directly to grade B and C areas. Single- or two-piece facility trouser suits, covering the full length of the arms and the legs, and facility socks covering the feet should be worn before entry to change rooms for grades B and C. Facility suits

and socks should not present a risk of contamination to the gowning area or processes.

- 7.15 Every operator entering grade B or A areas should gown into clean, sterilized protective garments (including eye coverings and masks) of an appropriate size at each entry. The maximum period for which the sterilized gown may be worn before replacement during a shift should be defined as part of the garment qualification.
- 7.16 Gloves should be regularly disinfected during operations. Garments and gloves should be changed immediately if they become damaged and present any risk of product contamination.
- 7.17 Reusable clean area clothing should be cleaned in a laundry facility adequately segregated from production operations, using a qualified process ensuring that the clothing is not damaged or contaminated by fibres or particles during the repeated laundry process. Laundry facilities used should not introduce risk of contamination or cross-contamination. The inappropriate handling and use of clothing may damage fibres and increase the risk of shedding of particles. After washing and before packing, garments should be visually inspected for damage and visual cleanliness. The garment management processes should be evaluated and determined as part of the garment qualification programme and should include a maximum number of laundry and sterilization cycles.
- 7.18 Activities in clean areas that are not critical to the production processes should be kept to a minimum, especially when aseptic operations are in progress. The movement of personnel should be slow, controlled and methodical to avoid excessive shedding of particles and organisms due to overvigorous activity. Operators performing aseptic operations should adhere to aseptic technique at all times to prevent changes in air currents that may introduce air of lower quality into the critical zone. Movement adjacent to the critical zone should be restricted and obstruction of the path of the unidirectional (first air) airflow should be avoided. A review of airflow visualization studies should be considered as part of the training programme.

8. Production and specific technologies

Terminally sterilized products

- 8.1 Preparation of components and materials should be performed in at least a grade D cleanroom in order to limit the risk of microbial, endotoxin/pyrogen and particle contamination, so that the product is suitable for

sterilization. Where the product is at a high or unusual risk of microbial contamination (for example, the product actively supports microbial growth and must be held for long periods before filling, or the product is not processed mostly in closed vessels), then preparation should be carried out in at least a grade C environment. The preparation of ointments, creams, suspensions and emulsions should be carried out in at least a grade C environment before terminal sterilization.

- 8.2 Primary packaging containers and components should be cleaned using validated processes to ensure that particle, endotoxin/pyrogen and bioburden contamination is appropriately controlled.
- 8.3 The filling of products for terminal sterilization should be carried out in at least a grade C environment.
- 8.4 Where the CCS identifies that the product is at an unusual risk of contamination from the environment – for example, when the filling operation is slow or when the containers are wide necked or are necessarily exposed for more than a few seconds before closing – then the product should be filled in grade A with at least a grade C background.
- 8.5 The processing of the bulk solution should include a filtration step with a microorganism-retaining filter, where possible, to reduce bioburden levels and particles prior to filling into the final product containers. The maximum permissible time between preparation and filling should be defined.
- 8.6 Examples of operations to be carried out in the various grades are given in Table. 3.

Table. 3

Examples of operations and grades for terminally sterilized preparation and processing operations

Grade	Operation
Grade A	<ul style="list-style-type: none"> • Filling of products, when unusually at risk
Grade C	<ul style="list-style-type: none"> • Preparation of solutions, when unusually at risk • Filling of products
Grade D	<ul style="list-style-type: none"> • Preparation of solutions and components for subsequent filling

Aseptic preparation and processing

- 8.7 The aseptic process should be clearly defined. The risks associated with the aseptic process, and any associated requirements, should be identified, assessed and appropriately controlled. The site's CCS should clearly define the acceptance criteria for these controls, requirements for monitoring and the review of their effectiveness. Methods and procedures to control these risks should be described and implemented. Accepted residual risks should be formally documented.
- 8.8 Precautions to minimize microbial, endotoxin/pyrogenic and particle contamination should be taken, as per the site's CCS, during the preparation of the aseptic environment, during all processing stages (including the stages before and after bulk product sterilization), and until the product is sealed in its final container. The presence of materials liable to generate particles and fibres should be minimized in cleanrooms.
- 8.9 Where possible, the use of equipment such as RABS, isolators or other systems should be considered in order to reduce the need for critical interventions into grade A and to minimize the risk of contamination. Robotics and automation of processes can also be considered to eliminate direct human critical interventions (for example, dry heat tunnel, automated lyophilizer loading, sterilization in place).
- 8.10 Examples of operations to be carried out in the various environmental grades are given in Table. 4.

Table. 4

Examples of operations and grades for aseptic preparation and processing operations

Grade	Operation
Grade A	<ul style="list-style-type: none"> • Aseptic assembly of filling equipment • Connections made under aseptic conditions (where sterilized product contact surfaces are exposed) that are post the final sterilizing grade filter; these connections should be sterilized by steam-in-place whenever possible • Aseptic compounding and mixing • Replenishment of sterile bulk product, containers and closures • Removal and cooling of unprotected (e.g. with no packaging) items from sterilizers • Staging and conveying of sterile primary packaging components in the aseptic filling line while not wrapped

Table 4 *continued*

Grade	Operation
	<ul style="list-style-type: none"> • Aseptic filling, sealing of containers such as ampoules, vial closure, transfer of open or partially stoppered vials • Loading of a lyophilizer
Grade B	<ul style="list-style-type: none"> • Background support for grade A (when not in an isolator) • Conveying or staging, while protected from the surrounding environment, of equipment, components and ancillary items for introduction into grade A
Grade C	<ul style="list-style-type: none"> • Preparation of solutions to be filtered, including sampling and dispensing
Grade D	<ul style="list-style-type: none"> • Cleaning of equipment • Handling of components, equipment and accessories after cleaning • Assembly under high-efficiency particulate air (HEPA)-filtered airflow of cleaned components, equipment and accessories prior to sterilization • Assembly of closed and sterilized SUS using intrinsic sterile connection devices

8.11 For sterile products where the final formulation cannot be filtered, the following should be considered:

- i. All product and component contact equipment should be sterilized prior to use.
- ii. All raw materials or intermediates should be sterilized and aseptically added.
- iii. Bulk solutions or intermediates should be sterilized.

8.12 The unwrapping, assembly and preparation of sterilized equipment, components and ancillary items with direct or indirect product contact should be treated as an aseptic process and performed in grade A with a grade B background. The filling line set-up and filling of the sterile product should be treated as an aseptic process and performed in grade A with a grade B background. Where an isolator is used, the background should be in accordance with paragraph 4.20.

8.13 Preparation and filling of sterile products such as ointments, creams, suspensions and emulsions should be performed in grade A with a grade B background when the product and components are exposed to the environment and the product is not subsequently filtered (via a sterilizing

grade filter) or terminally sterilized. Where an isolator or RABS is used, the background should be in accordance with paragraph 4.20.

- 8.14 Aseptic connections should be performed in grade A with a grade B background unless subsequently sterilized in place or conducted with intrinsic sterile connection devices that minimize any potential contamination from the immediate environment. Intrinsic sterile connection devices should be designed to mitigate risk of contamination.

Where an isolator is used, the background should be in accordance with paragraph 4.20. Aseptic connections should be appropriately assessed and their effectiveness verified (for requirements regarding intrinsic sterile connection devices, refer to paragraphs 8.129 and 8.130).

- 8.15 Aseptic manipulations (including non-intrinsic sterile connection devices) should be minimized through the use of engineering design solutions such as preassembled and sterilized equipment. Whenever feasible, product contact piping and equipment should be preassembled and sterilized in place.

- 8.16 There should be an authorized list of allowed and qualified interventions, both inherent and corrective, that may occur during production (refer to paragraph 9.34). Interventions should be carefully designed to ensure that the risk of contamination of the environment, process and product is effectively minimized. The process of designing interventions should include the consideration of any impact on airflows and critical surfaces and products. Engineering solutions should be used whenever possible to minimize incursion by operators during the intervention. Aseptic technique should be observed at all times, including the appropriate use of sterile tools for manipulations. The procedures listing the types of inherent and corrective interventions, and how to perform them, should be first evaluated via risk management and APS and should be kept up to date. Non-qualified interventions should only be used in exceptional circumstances, with due consideration of the risks associated with the intervention and with the authorization of the quality unit. The details of the intervention conducted should be subject to risk assessment, recorded and fully investigated under the manufacturer's PQS. Any non-qualified interventions should be thoroughly assessed by the quality department and considered during batch disposition.

- 8.17 Interventions and stoppages should be recorded in the batch record. Each line stoppage or intervention should be sufficiently documented in batch records with the associated time, duration of the event, and operators involved (refer to paragraph 9.34).

- 8.18 The duration of each aspect of aseptic preparation and processing should be minimized and limited to a defined and validated maximum time, including:
- i. the holding time between equipment, component, and container cleaning, drying and sterilization;
 - ii. the holding time for sterilized equipment, components, and containers before use and during filling or assembly;
 - iii. the holding time for a decontaminated environment, such as the RABS or isolator before use;
 - iv. the time between the start of the preparation of a product and its sterilization or filtration through a microorganism-retaining filter (if applicable), through to the end of the aseptic filling process (there should be a maximum permissible time defined for each product that takes into account its composition and the prescribed method of storage);
 - v. the holding time for sterilized product prior to filling;
 - vi. the aseptic processing time;
 - vii. the filling time.
- 8.19 Aseptic operations (including APS) should be monitored on a regular basis by personnel (independent from the aseptic operation) with specific expertise in aseptic processing to verify the correct performance of operations, including operator behaviour in the cleanroom, and to address inappropriate practices if detected. Records should be maintained.

Finishing of sterile products

- 8.20 Open primary packaging containers should be maintained under grade A conditions with the appropriate background for the technology, as described in paragraph 4.20 (for partially stoppered vials or prefilled syringes, refer to paragraph 8.126).
- 8.21 Filled containers should be closed by appropriately validated methods.
- 8.22 Where filled containers are closed by fusion – for example, blow-fill-seal (BFS), form-fill-seal (FFS), or small- or large-volume parenteral bags, glass or plastic ampoules – the critical parameters and variables that affect seal integrity should be evaluated, determined, effectively controlled and monitored during operations. Glass ampoules, BFS units and small-volume containers (≤ 100 mL) closed by fusion should be subject to 100% integrity testing using validated methods. For large-volume containers

(> 100 mL) closed by fusion, reduced sampling may be acceptable where scientifically justified and based on data demonstrating the consistency of the existing process, and a high level of process control. Visual inspection is not an acceptable integrity test method.

- 8.23 Samples of products using systems other than fusion should be taken and checked for integrity using validated methods. The frequency of testing should be based on the knowledge and experience of the container and closure systems being used. A scientifically justified sampling plan should be used. The sample size should be based on information such as supplier qualification, packaging component specifications and process knowledge.
- 8.24 Containers sealed under vacuum should be tested for maintenance of vacuum after an appropriate predetermined period prior to certification and release and during shelf life.
- 8.25 The container closure integrity validation should take into consideration any transportation or shipping requirements that may negatively impact the integrity of the container (for example, by decompression or extreme temperatures).
- 8.26 Where the equipment used to crimp vial caps can generate large quantities of non-viable particle, measures to prevent particle contamination, such as locating the equipment at a physically separate station equipped with adequate air extraction, should be taken.
- 8.27 Vial capping of aseptically filled products can be undertaken as an aseptic process using sterilized caps or as a clean process outside the aseptic processing area. Where the latter approach is adopted, vials should be protected by grade A conditions up to the point of leaving the aseptic processing area, and thereafter stoppered vials should be protected with a grade A air supply until the cap has been crimped. The supporting background environment of grade A air supply should meet at least grade D requirements. Where capping is a manual process, it should be performed under grade A conditions either in an appropriately designed isolator or in grade A with a grade B background.
- 8.28 Where capping of aseptically filled sterile product is conducted as a clean process with grade A air supply protection, vials with missing or displaced stoppers should be rejected prior to capping. Appropriately qualified, automated methods for stopper height detection should be in place.
- 8.29 Where human intervention is required at the capping station, appropriate technological and organizational measures should be used to prevent

direct contact with the vials and to minimize contamination. RABS and isolators may be beneficial in assuring the required conditions.

- 8.30 All filled containers of parenteral products should be inspected individually for extraneous contamination or other defects. Defect classification and criticality should be determined during qualification and based on risk and historical knowledge. Factors to consider include the potential impact of the defect on the patient and the route of administration. Different defect types should be categorized and batch performance analysed. Batches with unusual levels of defects, when compared with routine defect numbers for the process (based on routine and trend data), should be investigated. A defect library should be generated and maintained that captures all known classes of defects. The defect library should be used for the training of production and quality assurance personnel. Critical defects should not be identified during any subsequent sampling and inspection of acceptable containers. Any critical defect identified subsequently should trigger an investigation, as it indicates a possible failure of the original inspection process.
- 8.31 When inspection is performed manually, it should be conducted under suitable and controlled conditions of illumination and background. Inspection rates should be appropriately controlled and qualified. Operators performing the inspection should undergo visual inspection qualification (whilst wearing corrective lenses, if these are normally worn) at least annually. The qualification should be undertaken using appropriate samples from the manufacturer's defect library sets and taking into consideration worst-case scenarios (such as inspection time, line speed where the product is transferred to the operator by a conveyor system, container size and operator fatigue) and should include consideration of eyesight checks. Operator distractions should be minimized and frequent breaks of an appropriate duration should be taken from inspection.
- 8.32 Where automated methods of inspection are used, the process should be validated to detect known defects (which may impact product quality or safety) and be equal to, or better than, manual inspection methods. The performance of the equipment should be challenged using representative defects prior to start-up and at regular intervals throughout the batch.
- 8.33 The results of the inspection should be recorded and defect types and numbers trended. The reject levels for the various defect types should also be trended based on statistical principles. The impact to the product on the market should be assessed as part of the investigation when adverse trends are observed.

Sterilization

- 8.34 Where possible, the finished product should be terminally sterilized, using a validated and controlled sterilization process, as this provides greater assurance of sterility than a validated and controlled sterile filtration process and/or aseptic processing. Where it is not possible for a product to undergo terminal sterilization, consideration should be given to using post-aseptic processing terminal heat treatment, combined with an aseptic process to give improved sterility assurance.
- 8.35 The selection, design and location of the equipment and cycle or programme used for sterilization should be based on scientific principles and data that demonstrate repeatability and reliability of the sterilization process. All parameters should be defined and, where critical, these should be controlled, monitored and recorded.
- 8.36 All sterilization processes should be validated. Validation studies should take into account the product composition, storage conditions and maximum time between the start of the preparation of a product or material to be sterilized and its sterilization. Before any sterilization process is adopted, its suitability for the product and equipment, and its efficacy in consistently achieving the desired sterilizing conditions in all parts of each type of load to be processed, should be validated – notably by physical measurements and, where appropriate, by biological indicators. For effective sterilization, the whole of the product and surfaces of equipment and components should be subject to the required treatment, and the process should be designed to ensure that this is achieved.
- 8.37 Particular attention should be given when the adopted product sterilization method is not described in the current edition of the pharmacopoeia, or when it is used for a product that is not a simple aqueous solution. Where possible, heat sterilization is the method of choice.
- 8.38 Validated loading patterns should be established for all sterilization processes and load patterns should be subject to periodic revalidation. Maximum and minimum loads should also be considered as part of the overall load validation strategy.
- 8.39 The validity of the sterilizing process should be reviewed and verified at scheduled intervals based on risk. Heat sterilization cycles should be revalidated with a minimum frequency of at least annually for load patterns that are considered worst case. Other load patterns should be validated at a frequency justified in the CCS.

- 8.40 Routine operating parameters should be established and adhered to for all sterilization processes (for example, physical parameters and loading patterns).
- 8.41 There should be mechanisms in place to detect a sterilization cycle that does not conform to the validated parameters. Any failed sterilization or sterilization that deviates from the validated process (for example, having longer or shorter phases such as heating cycles) should be investigated.
- 8.42 Suitable biological indicators placed at appropriate locations should be considered as an additional method to support the validation of the sterilization process. Biological indicators should be stored and used according to the manufacturer's instructions. Where biological indicators are used to support validation or to monitor a sterilization process (for example, with ethylene oxide), positive controls should be tested for each sterilization cycle. If biological indicators are used, strict precautions should be taken to avoid transferring microbial contamination to the manufacturing or other testing processes. Biological indicator results in isolation should not be used to override other critical parameters and process design elements.
- 8.43 The reliability of biological indicators is important. Suppliers should be qualified and transportation and storage conditions should be controlled in order that biological indicator quality is not compromised. Prior to use of a new batch or lot of biological indicators, the population, purity and identity of the indicator organism of the batch or lot should be verified. For other critical parameters (such as D-value or Z-value), the batch certificate provided by the qualified supplier can normally be used.
- 8.44 There should be a clear means of differentiating products, equipment and components that have not been subjected to the sterilization process from those that have. Equipment, such as baskets or trays used to carry products and other items of equipment or components, should be clearly labelled (or electronically tracked) with the product name and batch number and an indication as to whether or not it has been sterilized. Indicators – such as autoclave tape or irradiation indicators – may be used, where appropriate, to indicate whether or not a batch (or sub-batch material, component or equipment) has passed through a sterilization process. These indicators show only that the sterilization process has occurred; they do not indicate product sterility or achievement of the required sterility assurance level.
- 8.45 Sterilization records should be available for each sterilization run. Each cycle should have a unique identifier. Their conformity should be reviewed and approved as part of the batch certification or release procedure.

- 8.46 Where required, materials, equipment and components should be sterilized by validated methods appropriate to the specific material. Suitable protection after sterilization should be provided to prevent recontamination. If sterilized items are not used immediately after sterilization, these should be stored using appropriately sealed packaging and the established maximum hold time should be followed. Where justified, components that have been packaged with multiple sterile packaging layers need not be stored in a cleanroom if the integrity and configuration of the sterile pack allows the items to be readily disinfected during transfer by operators into grade A (for example, by the use of multiple sterile coverings that can be removed at each transfer from lower to higher grade). Where protection is achieved by containment in sealed packaging, this packaging process should be undertaken prior to sterilization.
- 8.47 Where materials, equipment, components and ancillary items are sterilized in sealed packaging and then transferred into grade A, this should be done using appropriate, validated methods (for example, airlocks or pass-through hatches) with accompanying disinfection of the exterior of the sealed packaging. The use of rapid transfer port technology should also be considered. These methods should be demonstrated to effectively control the potential risk of contamination of the grade A and B areas and, likewise, the disinfection procedure should be demonstrated to be effective in reducing any contamination on the packaging to acceptable levels for entry of the item into the grade A and B areas.
- 8.48 Where materials, equipment, components and ancillary items are sterilized in sealed packaging or containers, the packaging should be qualified for minimizing the risk of particulate, microbial, endotoxin/pyrogen or chemical contamination, and for compatibility with the selected sterilization method. The packaging sealing process should be validated. The validation should consider the integrity of the sterile protective barrier system, the maximum hold time before sterilization and the maximum shelf-life assigned to the sterilized items. The integrity of the sterile protective barrier system for each of the sterilized items should be checked prior to use.
- 8.49 For materials, equipment, components and ancillary items that are not a direct or indirect product contact part and are necessary for aseptic processing but cannot be sterilized, an effective and validated disinfection and transfer process should be in place. These items, once disinfected, should be protected to prevent recontamination. These items, and others representing potential routes of contamination, should be included in the environmental monitoring programme.

Sterilization by heat

- 8.50 Each heat sterilization cycle should be recorded either electronically or by hard copy, using equipment with suitable accuracy and precision. The system should have safeguards or redundancy in its control and monitoring instrumentation to detect a cycle not conforming to the validated cycle parameter requirements and abort or fail this cycle (for example, by the use of duplex or double probes connected to independent control and monitoring systems).
- 8.51 The position of the temperature probes used for controlling and recording should be determined during the validation and selected based on system design and in order to correctly record and represent routine cycle conditions. Validation studies should be designed to demonstrate the suitability of system control and recording probe locations, and should include the verification of the function and location of these probes by the use of an independent monitoring probe located at the same position during validation.
- 8.52 The whole of the load should reach the required temperature before measurement of the sterilizing time period starts. For sterilization cycles controlled by using a reference probe within the load, specific consideration should be given to ensuring that the load probe temperature is controlled within a defined temperature range prior to cycle commencement.
- 8.53 After completion of the high-temperature phase of a heat sterilization cycle, precautions should be taken against contamination of a sterilized load during cooling. Any cooling liquid or gas that comes into contact with the product or sterilized material should be sterilized.
- 8.54 In those cases where parametric release has been authorized, a robust system should be applied to the product life cycle validation and the routine monitoring of the manufacturing process. This system should be periodically reviewed.

Moist heat sterilization

- 8.55 Moist heat sterilization can be achieved using steam (direct or indirect contact), but also includes other systems such as superheated water systems (cascade or immersion cycles) that could be used for containers that may be damaged by other cycle designs (such as BFS containers or plastic bags).
- 8.56 The items to be sterilized, other than products in sealed containers, should be dry and packaged in a protective barrier system that allows

removal of air and penetration of steam and prevents recontamination after sterilization. All loaded items should be dry upon removal from the sterilizer. Load dryness should be confirmed by visual inspection as a part of the sterilization process acceptance.

- 8.57 For porous cycles (hard goods), time, temperature and pressure should be used to monitor the process and should be recorded. Each sterilized item should be inspected for damage, packaging material integrity and moisture upon removal from the autoclave. Any item found not to be fit for purpose should be removed from the manufacturing area and an investigation performed.
- 8.58 For autoclaves capable of performing prevacuum sterilization cycles, the temperature should be recorded at the chamber drain throughout the sterilization period. Load probes may also be used where appropriate but the controlling system should remain related to the load validation. For steam-in-place systems, the temperature should be recorded at appropriate condensate drain locations throughout the sterilization period.
- 8.59 Validation of porous cycles should include a calculation of equilibration time, exposure time, correlation of pressure and temperature, and the minimum/maximum temperature range during exposure. Validation of fluid cycles should include temperature, time and F_0 . Critical processing parameters should be subject to defined limits (including appropriate tolerances) and be confirmed as part of the sterilization validation and routine cycle acceptance criteria.
- 8.60 Leak tests on the sterilizer should be carried out periodically (normally weekly) when a vacuum phase is part of the cycle or the system is returned, post-sterilization, to a pressure lower than the environment surrounding the sterilizer.
- 8.61 There should be adequate assurance of air removal prior to and during sterilization when the sterilization process includes air purging (for example, porous autoclave loads, lyophilizer chambers). For autoclaves, this should include an air removal test cycle (normally performed on a daily basis) or the use of an air detector system. Loads to be sterilized should be designed to support effective air removal and be free draining to prevent the build-up of condensate.
- 8.62 Distortion and damage of non-rigid containers that are terminally sterilized, such as containers produced by BFS or FFS technologies, should be prevented by appropriate cycle design and control (for instance, setting correct pressure, heating and cooling rates and loading patterns).

- 8.63 Where steam-in-place systems are used for sterilization (for example, for fixed pipework, vessels and lyophilizer chambers), the system should be appropriately designed and validated to ensure that all parts of the system are subjected to the required treatment. The system should be monitored for temperature, pressure and time at appropriate locations during routine use to ensure all areas are effectively and reproducibly sterilized. These locations should be demonstrated as being representative of, and correlated with, the slowest to heat locations during initial and routine validation. Once a system has been sterilized by steam-in-place it should remain integral and, where operations require, be maintained under positive pressure or otherwise equipped with a sterilizing vent filter prior to use.
- 8.64 In fluid load cycles where superheated water is used as the heat transfer medium, the heated water should consistently reach all of the required contact points. Initial qualification studies should include temperature mapping of the entire load. There should be routine checks on the equipment to ensure that nozzles (where the water is introduced) are not blocked and drains remain free from debris.
- 8.65 Validation of the sterilization of fluid loads in a superheated water autoclave should include temperature mapping of the entire load and heat penetration and reproducibility studies. All parts of the load should heat up uniformly and achieve the desired temperature for the specified time. Routine temperature monitoring probes should be correlated to the worst-case positions identified during the qualification process.

Dry heat sterilization

- 8.66 Dry heat sterilization utilizes high temperatures of air or gas to sterilize a product or article. Dry heat sterilization is of particular use in the thermal removal of difficult-to-eliminate thermally robust contaminants such as endotoxin/pyrogen and is often used in the preparation of components for aseptic filling. The combination of time and temperature to which product, components or equipment are exposed should produce an adequate and reproducible level of lethality and endotoxin/pyrogen inactivation or removal when operated routinely within the established limits. The process may be operated in an oven or in a continuous tunnel process (for example, for sterilization and depyrogenation of glass containers).
- 8.67 Dry heat sterilization or depyrogenation tunnels should be configured to ensure that airflow protects the integrity and performance of the grade A sterilizing zone by maintaining appropriate pressure differentials and airflow through the tunnel. Air pressure difference profiles should be

established and monitored. Departures from established limits should be investigated, where appropriate. The impact of any airflow change should be assessed to ensure the heating profile is maintained. All air supplied to the tunnel should pass through at least a HEPA filter and periodic tests (at least every six months) should be performed to demonstrate air filter integrity. Any tunnel parts that come into contact with sterilized components should be appropriately sterilized or disinfected. Critical process parameters that should be considered during validation or routine processing should include:

- i. belt speed and dwell time within the sterilizing zone;
- ii. minimum and maximum temperatures;
- iii. heat penetration of the material or article;
- iv. heat distribution and uniformity;
- v. airflows determined by air pressure differential profiles correlated with the heat distribution and penetration studies.

8.68 When a thermal process is used as part of the depyrogenation process for any component or product contact equipment or material, validation studies should be performed to demonstrate that the process provides a suitable F_h value and results in a minimum $3 \log_{10}$ reduction in endotoxin concentration. When this is attained, there is no additional requirement to demonstrate sterilization in these cases.

8.69 Containers spiked with endotoxin should be used during validation and should be carefully managed with a full reconciliation performed. Containers should be representative of the materials normally processed (in respect to composition of the packaging materials, porosity, dimensions and nominal volume). Endotoxin quantification and recovery efficiency should also be demonstrated.

8.70 Dry heat ovens are typically employed to sterilize or depyrogenate primary packaging components, starting materials or active substances but may be used for other processes. They should be maintained at a positive pressure relative to lower-grade clean areas throughout the sterilization and post-sterilization hold process unless the integrity of the packaging is maintained. All air entering the oven should pass through a HEPA filter. Critical process parameters that should be considered in qualification or routine processing should include:

- i. temperature;
- ii. exposure period or time;

- iii. chamber pressure (for maintenance of overpressure);
- iv. air speed;
- v. air quality within the oven;
- vi. heat penetration of material or article (slow-to-heat spots);
- vii. heat distribution and uniformity;
- viii. load pattern and configuration of articles to be sterilized or depyrogenated, including minimum and maximum loads.

Sterilization by radiation

- 8.71 Sterilization by radiation is used mainly for the sterilization of heat-sensitive materials and products. Ultraviolet irradiation is not an acceptable method of sterilization.
- 8.72 Validation procedures should ensure that the effects of variation in the density of the product and packages are considered.

Sterilization with ethylene oxide

- 8.73 This method should only be used when no other method is practicable. During process validation, it should be shown that there is no damaging effect on the product and that the conditions and time allowed for degassing result in the reduction of any residual ethylene oxide gas and reaction products to defined acceptable limits for the given product or material.
- 8.74 Direct contact between gas and microbial cells is essential. Precautions should be taken to avoid the presence of organisms likely to be enclosed in material, such as crystals or dried protein. The nature, porosity and quantity of packaging materials can significantly affect the process.
- 8.75 Before exposure to the gas, materials should be brought into equilibrium with the humidity and temperature required by the process. Where steam is used to condition the load for sterilization, it should be of an appropriate quality. The time required for this should be balanced against the opposing need to minimize the time before sterilization.
- 8.76 Each sterilization cycle should be monitored with suitable biological indicators, using the appropriate number of test units distributed throughout the load at defined locations that have been shown to be worst-case locations during validation.
- 8.77 Critical process parameters that should be considered as part of the sterilization process validation and routine monitoring include:

- i. ethylene oxide gas concentration
 - ii. pressure
 - iii. the amount of ethylene oxide gas used
 - iv. relative humidity
 - v. temperature
 - vi. exposure time.
- 8.78 After sterilization, the load should be aerated to allow ethylene oxide gas or its reaction products to desorb from the packaged product to predetermined levels. Aeration can occur within a sterilizer chamber or in a separate aeration chamber or aeration room. The aeration phase should be validated as part of the overall ethylene oxide sterilization process validation.

Sterilization by filtration of products that cannot be sterilized in their final container

- 8.79 If the product cannot be sterilized in its final container, solutions or liquids should be sterilized by filtration through a sterile sterilizing grade filter (with a nominal pore size of a maximum of 0.22 μm that has been appropriately validated to obtain a sterile filtrate) and subsequently aseptically filled into a previously sterilized container. The selection of the filter used should ensure that it is compatible with the product and is as described in the marketing authorization (refer to paragraph 8.135).
- 8.80 Suitable bioburden reduction prefilters or sterilizing grade filters may be used at multiple points during the manufacturing process to ensure a low and controlled bioburden of the liquid prior to the final sterilizing filter. Due to the potential additional risks of a sterile filtration process, as compared with other sterilization processes, an additional filtration through a sterile sterilizing grade filter, as close to the point of fill as possible, should be considered as part of an overall CCS.
- 8.81 The selection of components for the filtration system and their interconnection and arrangement within the filtration system, including prefilters, should be based on the critical quality attributes of the product, justified and documented. The filtration system should minimize the generation of fibres and particles and should not cause or contribute to unacceptable levels of impurities or possess characteristics that otherwise alter the quality and efficacy of the product. Similarly, the filter characteristics should be compatible with the fluid and not be adversely

affected by the product to be filtered. Adsorption of product components and extraction or leaching of filter components should be evaluated (refer to paragraph 8.135).

- 8.82 The filtration system should be designed to:
- i. allow operation within validated process parameters;
 - ii. maintain the sterility of the filtrate;
 - iii. minimize the number of aseptic connections required between the final sterilizing grade filter and the final filling of the product;
 - iv. allow cleaning procedures to be conducted as necessary;
 - v. allow sterilization procedures, including sterilization in place, to be conducted as necessary;
 - vi. permit in-place integrity testing of the 0.22 µm final sterilizing grade filter, preferably as a closed system, both prior to and following filtration as necessary; in-place integrity testing methods should be selected to avoid any adverse impact on the quality of the product.
- 8.83 Sterile filtration of liquids should be validated in accordance with relevant pharmacopoeial requirements. Validation can be grouped by different strengths or variations of a product but should be based on risk (for example, product and conditions). The rationale for grouping should be justified and documented.
- 8.84 During filter validation, wherever possible, the product to be filtered should be used for bacterial retention testing of the sterilizing grade filter. Where the product to be filtered is not suitable for use in bacterial retention testing, a suitable surrogate product should be selected and should be justified for use in the test. The challenge organism used in the bacterial retention test should be justified.
- 8.85 Filtration parameters that should be considered and established during validation should include:
- i. The wetting fluid used for filter integrity testing should be based on the filter manufacturer's recommendation or the fluid to be filtered. The appropriate integrity test value specification should be established.
 - ii. If the system is flushed or integrity tested in situ with a fluid other than the product, the appropriate actions should be taken to avoid any deleterious effect on product quality.

Filtration process conditions to be considered include:

- i. fluid prefiltration holding time and effect on bioburden;
- ii. filter conditioning, with fluid if necessary;
- iii. maximum filtration time or total time filter is in contact with the fluid;
- iv. maximum operating pressure;
- v. flow rate;
- vi. maximum filtration volume;
- vii. temperature;
- viii. the time taken to filter a known volume of bulk solution and the pressure difference to be used across the filter.

8.86 Routine process controls should be implemented to ensure adherence to validated filtration parameters. The results of critical process parameters should be included in the batch record, including the minimum time taken to filter a known volume of bulk solution and pressure difference across the filter. Any significant difference from critical parameters during manufacturing should be documented and investigated.

8.87 The integrity of the sterilized filter assembly should be verified by integrity testing before use (pre-use post-sterilization integrity test or PUPSIT) to check for damage and loss of integrity caused by the filter preparation prior to use. A sterilizing grade filter that is used to sterilize a fluid should be subject to a non-destructive integrity test post-use prior to removal of the filter from its housing. The integrity test process should be validated and test results should correlate to the microbial retention capability of the filter established during validation. Examples of tests that are used include bubble point, diffusive flow, water intrusion or pressure hold test. It is recognized that PUPSIT may not always be possible after sterilization due to process constraints (such as the filtration of very small volumes of solution). In these cases, an alternative approach may be taken provided that a thorough risk assessment has been performed and compliance is achieved by the implementation of appropriate controls to mitigate any risk of a non-integral filtration system. Points to consider in such a risk assessment should include:

- i. in-depth knowledge and control of the filter sterilization process to ensure that the potential for damage to the filter is minimized;
- ii. in-depth knowledge and control of the supply chain to include:
 - contract sterilization facilities

- defined transport mechanisms
 - packaging of the sterilized filter to prevent damage to the filter during transportation and storage;
- iii. in-depth process knowledge, such as:
- the specific product type, including particle burden and whether there exists any risk of impact on filter integrity values, such as the potential to alter integrity testing values and therefore prevent the detection of a non-integral filter during a post-use filter integrity test;
 - prefiltration and processing steps, prior to the final sterilizing grade filter, which would remove particle burden and clarify the product prior to the sterile filtration.
- 8.88 The integrity of critical sterile gas and air vent filters (that are directly linked to the sterility of the product) should be verified by testing after use, with the filter remaining in the filter assembly or housing.
- 8.89 The integrity of non-critical air or gas vent filters should be confirmed and recorded at appropriate intervals. Where gas filters are in place for extended periods, integrity testing should be carried out at installation and prior to replacement. The maximum duration of use should be specified and monitored based on risk (for example, considering the maximum number of uses and heat treatment or sterilization cycles permitted, as applicable).
- 8.90 For gas filtration, unintended moistening or wetting of the filter or filter equipment should be avoided.
- 8.91 If the sterilizing filtration process has been validated as a system consisting of multiple filters to achieve the sterility for a given fluid, the filtration system is considered to be a single sterilizing unit and all filters within the system should satisfactorily pass integrity testing after use.
- 8.92 In a redundant filtration system (where a second redundant sterilizing grade filter is present as a backup but the sterilizing process is validated as only requiring one filter), a post-use integrity test of the primary sterilizing grade filter should be performed and, if it is demonstrated to be integral, then a post-use integrity test of the redundant (backup) filter is not necessary. However, in the event of a failure of the post-use integrity test on the primary filter, a post-use integrity test on the secondary (redundant) filter should be performed, in conjunction with an investigation and risk assessment to determine the reason for the primary filter test failure.

- 8.93 Bioburden samples should be taken from the bulk product and immediately prior to the final sterile filtration. In cases where a redundant filtration set-up is used, it should be taken prior to the first filter. Systems for taking samples should be designed so as not to introduce contamination.
- 8.94 Liquid sterilizing grade filters should be discarded after the processing of a single batch and the same filter should not be used continuously for more than one working day unless such use has been validated.
- 8.95 Where campaign manufacture of a product has been appropriately justified in the CCS and validated, the filter user should:
- i. assess and document the risks associated with the duration of filter use for the sterile filtration process for a given fluid;
 - ii. conduct and document effective validation and qualification studies to demonstrate that the duration of filter use for a given sterile filtration process and for a given fluid does not compromise the performance of the final sterilizing grade filter or filtrate quality;
 - iii. document the maximum validated duration of use for the filter and implement controls to ensure that filters are not used beyond the validated maximum duration, and maintain records of these controls;
 - iv. implement controls to ensure that filters contaminated with fluid or cleaning agent residues, or considered defective in any other way, are removed from use.

Form-fill-seal (FFS)

- 8.96 The conditions for FFS machines used for terminally sterilized products should comply with the environmental requirements of paragraphs 8.3 and 8.4 of this guideline. The conditions for FFS machines used in aseptic manufacture should comply with the environmental requirements of paragraph 8.10 of this guideline.
- 8.97 Contamination of the packaging films used in the FFS process should be minimized by appropriate controls during component production, supply and handling. Due to the criticality of packaging films, procedures should be implemented to ensure that the films supplied meet defined specifications and are of the appropriate quality, including material thickness and strength, microbial and particulate contamination, integrity and artwork, as relevant. The sampling frequency, the bioburden and, where applicable, endotoxin/pyrogen levels of packaging films and associated components should be defined and controlled within the PQS and considered in the CCS.

- 8.98 Particular attention should be given to understanding and assessing the operation of the equipment, including set-up, filling, sealing and cutting processes, so that critical process parameters are understood, validated, controlled and monitored appropriately.
- 8.99 Any product contact gases (such as those used to inflate the container or used as a product overlay) should be appropriately filtered, as close to the point of use as possible. The quality of gases used and the effectiveness of gas filtration systems should be verified periodically in accordance with paragraphs 6.18 and 6.19.
- 8.100 The controls identified during qualification of FFS should be in alignment with the CCS. Aspects to be considered include:
- i. determination of the boundaries of the critical zone;
 - ii. environmental control and monitoring of both the machine and the background in which it is placed;
 - iii. personnel gowning requirements;
 - iv. integrity testing of the product filling lines and filtration systems, as relevant;
 - v. duration of the batch or filling campaign;
 - vi. control of packaging films, including any requirements for film decontamination or sterilization;
 - vii. cleaning in place and sterilization in place of equipment, as necessary;
 - viii. machine operation, settings and alarm management, as relevant.
- 8.101 Critical process parameters for FFS should be determined during equipment qualification and should include:
- i. settings for uniform package dimensions and cutting in accordance with validated parameters;
 - ii. setting, maintenance and monitoring of validated forming temperatures (including preheating and cooling), forming times and pressures, as relevant;
 - iii. setting, maintenance and monitoring of validated sealing temperatures, sealing temperature uniformity across the seal, sealing times and pressures, as relevant;
 - iv. environmental and product temperature;
 - v. batch-specific testing of package seal strength and uniformity;
 - vi. settings for correct filling volumes, speeds and uniformity;

- vii. settings for any additional printing (batch coding), embossing or debossing to ensure that unit integrity is not compromised;
 - viii. methods and parameters for integrity testing of filled containers (refer to paragraph 8.22).
- 8.102 The appropriate procedures for the verification, monitoring and recording of FFS critical process parameters and equipment operation should be applied during production.
- 8.103 Operational procedures should describe how forming and sealing issues are detected and rectified. Rejected units or sealing issues should be recorded and investigated.
- 8.104 The appropriate maintenance procedures should be established based on risk, and should include maintenance and inspection plans for tooling critical to the effectiveness of unit sealing. Any issues identified that indicate a potential product quality concern should be documented and investigated.

Blow-fill-seal (BFS)

- 8.105 BFS equipment used for the manufacture of products that are terminally sterilized should be installed in at least a grade D environment. The conditions at the point of fill should comply with the environmental requirements of paragraphs 8.3 and 8.4.
- 8.106 BFS used for aseptic processing:
- i. For shuttle type equipment used for aseptic filling, the parison is open to the environment. Therefore the areas where parison extrusion, blow moulding and sealing take place should meet grade A conditions at the critical zones. The filling environment should be designed and maintained to meet grade A conditions for viable and total particle limits both at rest and when in operation.
 - ii. For rotary-type equipment used for aseptic filling, the parison is generally closed to the environment once formed. The filling environment within the parison should be designed and maintained to meet grade A conditions for viable and total particle limits both at rest and when in operation.
 - iii. The equipment should be installed in at least a grade C environment, provided that grade A/B clothing is used. The microbiological monitoring of operators wearing grade A/B clothing in a grade C area should be performed in accordance with risk management

principles. The limits and monitoring frequencies should be applied with consideration of the activities performed by these operators.

- 8.107 Due to the generation of particles from polymer extrusion, cutting during operation, and the restrictive size of critical filling zones of BFS equipment, in operation monitoring of total particle for BFS equipment is not expected. However, data should be available to demonstrate that the design of the equipment ensures that critical zones of the filling process environment would meet grade A conditions in operation.
- 8.108 Viable environmental monitoring of BFS processes should be risk based and designed in accordance with section 9 of this guideline. In operation viable monitoring should be undertaken for the full duration of critical processing, including equipment assembly. For rotary-type BFS equipment, it is acknowledged that monitoring of the critical filling zone may not be possible.
- 8.109 The environmental control and monitoring programme should take into consideration the moving parts and complex airflow paths generated by the BFS process and the effect of the high heat outputs of the process (for example, through the use of airflow visualization studies or other equivalent studies). Environmental monitoring programmes should also consider factors such as air filter configuration, air filter integrity, cooling system integrity (refer to paragraph 6.21), equipment design and qualification.
- 8.110 Air or other gases that make contact with critical surfaces of the container during extrusion, formation or sealing of the moulded container should undergo appropriate filtration. The quality of gas used and the effectiveness of gas filtration systems should be verified periodically in accordance with paragraphs 6.18 and 6.19.
- 8.111 Particulate and microbial contamination of the polymer granulate should be prevented by the appropriate design, control and maintenance of the polymer granulate storage, sampling and distribution systems.
- 8.112 The capability of the extrusion system to provide appropriate sterility assurance for the moulded container should be understood and validated. The sampling frequency, the bioburden and, where applicable, endotoxin/pyrogen levels of the raw polymer should be defined and controlled within the PQS and considered in the CCS.
- 8.113 Interventions requiring cessation of filling or extrusion, moulding and sealing and, where required, resterilization of the filling machine should

be clearly defined and described in the filling procedure, and included in the APS as relevant (refer to paragraphs 9.34, 9.35 and 9.36).

8.114 The controls identified during qualification of BFS should be in alignment with the site's CCS. Aspects to be considered include:

- i. determination of the boundaries of the critical zone;
- ii. environmental control and monitoring of both the machine and the background in which it is placed;
- iii. personnel gowning requirements;
- iv. integrity testing of the product filling lines and filtration systems, as relevant;
- v. duration of the batch or filling campaign;
- vi. control of polymer granulate, including distribution systems and critical extrusion temperatures;
- vii. cleaning in place and sterilization in place of equipment, as necessary;
- viii. machine operation, settings and alarm management, as relevant.

8.115 Critical process parameters for BFS should be determined during equipment qualification and should include:

- i. cleaning in place and sterilization in place of product pipelines and filling needles (mandrels);
- ii. setting, maintenance and monitoring of extrusion parameters, including temperature, speed and extruder throat settings for parison thickness;
- iii. setting, maintenance and monitoring of mould temperatures, including rate of cooling where necessary for product stability;
- iv. preparation and sterilization of ancillary components added to the moulded unit, such as bottle caps;
- v. environmental control, cleaning, sterilization and monitoring of the critical extrusion, transfer and filling areas, as relevant;
- vi. batch-specific testing of package wall thickness at critical points of the container;
- vii. settings for correct filling volumes, speeds and uniformity;
- viii. settings for any additional printing (batch coding), embossing or debossing to ensure that unit integrity and quality are not compromised;

- ix. methods and parameters for integrity testing of 100% of all filled containers (refer to paragraph 8.22);
 - x. settings for cutters or punches used to remove waste plastic surrounding filled units (flash removal).
- 8.116 The appropriate procedures for the verification, monitoring and recording of BFS critical process parameters and equipment operation should be applied during production.
- 8.117 Operational procedures should describe how blowing, forming and sealing issues are detected and rectified. Rejected units or sealing issues should be recorded and investigated.
- 8.118 Where the BFS process includes the addition of components to moulded containers (for example, addition of caps to large-volume parenteral bottles), these components should be appropriately decontaminated and added to the process using a clean, controlled process.
- i. For aseptic processes, the addition of components should be performed under grade A conditions to ensure the sterility of critical surfaces using presterilized components.
 - ii. For terminally sterilized products, the validation of terminal sterilization processes should ensure the sterility of all critical product pathways between the component and moulded container, including areas that are not wetted during sterilization.
 - iii. Testing procedures should be established and validated to ensure the effective sealing of components and moulded containers.
- 8.119 The appropriate maintenance procedures should be established based on risk, and should include maintenance and inspection plans for items critical to unit sealing, integrity and sterility.
- 8.120 The moulds used to form containers are considered critical equipment and any changes or modification to moulds should result in an assessment of finished product container integrity and, where the assessment indicates, should be supported by validation. Any issues identified that indicate a potential product quality concern should be documented and investigated.

Lyophilization

- 8.121 Lyophilization is a critical process step and all activities that can affect the sterility of the product or material need to be regarded as extensions of the aseptic processing of the sterilized product. The lyophilization

equipment and its processes should be designed to ensure that product or material sterility is maintained during lyophilization by preventing microbial and particle contamination between the filling of products for lyophilization and completion of the lyophilization process. All control measures in place should be determined by the site's CCS.

- 8.122 The sterilization of the lyophilizer and associated equipment (such as trays and vial support rings) should be validated, and the holding time between the sterilization cycle and use appropriately challenged during APS (refer to paragraph 9.33). Resterilization should be performed following maintenance or cleaning. Sterilized lyophilizers and associated equipment should be protected from contamination after sterilization.
- 8.123 Lyophilizers and associated product transfer and loading or unloading areas should be designed to minimize operator intervention as far as possible. The frequency of lyophilizer sterilization should be determined based on the design and risks related to system contamination during use. Lyophilizers that are manually loaded or unloaded with no barrier technology separation should be sterilized before each load. For lyophilizers loaded and unloaded by automated systems or protected by closed barrier systems, the frequency of sterilization should be justified and documented as part of the CCS.
- 8.124 The integrity of the lyophilizer should be maintained following sterilization and during lyophilization. The filter used to maintain lyophilizer integrity should be sterilized before each use of the system and its integrity testing results should be part of the batch certification and release. The frequency of vacuum and leak integrity testing of the chamber should be documented and the maximum permitted leakage of air into the lyophilizer should be specified and checked at the start of every cycle.
- 8.125 Lyophilization trays should be checked regularly to ensure that they are not misshapen or damaged.
- 8.126 Points to consider for the design of loading (and unloading, where the lyophilized material is still unsealed and exposed) include:
- i. Loading patterns within the lyophilizer are specified and documented.
 - ii. The transfer of partially closed containers to a lyophilizer are undertaken under grade A conditions at all times and handled in a manner designed to minimize direct operator intervention. Technologies such as conveyor systems or portable transfer systems

(for example, clean air transfer carts, portable unidirectional airflow workstations) should be used to ensure that the cleanliness of the system used to transfer the partially closed containers is maintained. Alternatively, where supported by validation, trays closed in a grade A area and not reopened whilst in the grade B area may be used to protect partially stoppered vials (such as appropriately closed boxes).

- iii. Airflow patterns are not to be adversely affected by transport devices and venting of the loading zone.
- iv. Unsealed containers (such as partially stoppered vials) are maintained under grade A conditions and should normally be separated from operators by physical barrier technology or any other appropriate measures.
- v. With regard to opening the lyophilizer chamber after incomplete closure or partial stoppering of product or material, product removed from the lyophilizer should remain under grade A conditions during subsequent handling.
- vi. Utensils used during loading and unloading of the lyophilizer (such as trays, bags, placing devices and tweezers) should be kept sterile.

Closed systems

- 8.127 The use of closed systems can reduce the risk of microbial, particle and chemical contamination from the adjacent environment. Closed systems should always be designed to reduce the need for manual manipulation and the associated risks.
- 8.128 It is critical to ensure the sterility of all product contact surfaces of closed systems used for aseptic processing. The design and selection of any closed system used for aseptic processing should ensure that sterility is achieved and maintained. The connection of sterile equipment (such as tubing or pipework) to the sterilized product pathway after the final sterilizing grade filter should be designed to be connected aseptically (for example, by intrinsic sterile connection devices).
- 8.129 The appropriate measures should be in place to ensure the integrity of components used in aseptic connections. The means by which this is achieved should be determined and captured in the CCS. The appropriate system integrity tests should be considered when there is a risk of compromising product sterility. The supplier assessment should include the collation of data in relation to potential failure modes that may lead to a loss of system sterility.

8.130 The background environment in which closed systems are located should be based on their design and the processes undertaken. For aseptic processing and where there are any risks that system integrity may be compromised, the system should be located in grade A. If the system can be shown to remain integral at every usage (for example, via pressure testing and monitoring) then a lower-classified area may be used. Any transfer between classified areas should be thoroughly assessed (refer to paragraph 4.10). If the closed system is opened (for example, for maintenance of a bulk manufacturing line), then this should be performed in a classified area appropriate to the materials (for example, grade C for terminal sterilization processes or grade A for aseptic processing) or be subject to further cleaning and disinfection (and sterilization in the case of aseptic processes).

Single-use systems

8.131 Single-use systems (SUS) are those technologies used in manufacture of sterile products that are used as an alternative to reusable equipment. They can be individual components or made up of multiple components such as bags, filters, tubing, connectors, valves, storage bottles and sensors. SUS should be designed to reduce the need for manipulation and complexity of manual interventions.

8.132 There are some specific risks associated with SUS that should be assessed as part of the CCS. These risks include:

- i. the interaction between the product and product contact surface (such as adsorption, or leachables and extractables);
- ii. the fragile nature of the system compared with fixed reusable systems;
- iii. the increase in the number and complexity of manual operations (including inspection and handling of the system) and connections made;
- iv. the complexity of the assembly;
- v. the performance of the pre- and post-use integrity testing for sterilizing grade filters (refer to paragraph 8.87);
- vi. the risk of holes and leakage;
- vii. the potential for compromising the system at the point of opening the outer packaging;
- viii. the risk of particle contamination.

- 8.133 Sterilization processes for SUS should be validated and shown to have no adverse impact on system performance.
- 8.134 The assessment of suppliers of disposable systems, including sterilization, is critical to the selection and use of these systems. For sterile SUS, verification of sterility assurance should be performed as part of the supplier qualification and evidence of sterilization of each unit should be checked on receipt.
- 8.135 The adsorption and reactivity of the product with product contact surfaces should be evaluated under process conditions.
- 8.136 The extractable and leachable profiles of the SUS and any impact on the quality of the product, especially where the system is made from polymer-based materials, should be evaluated. An assessment should be carried out for each component to evaluate the applicability of the extractable profile data. For components considered to be at high risk from leachables, including those that may absorb processed materials or those with extended material contact times, an assessment of leachable profile studies, including safety concerns, should be taken into consideration. If applying simulated processing conditions, these should accurately reflect the actual processing conditions and be based on a scientific rationale.
- 8.137 SUS should be designed to maintain integrity throughout processing under the intended operational conditions. Attention to the structural integrity of the single-use components is necessary where these may be exposed to more extreme conditions (such as freezing and thawing processes) during either routine processing or transportation. This should include verification that intrinsic sterile connection devices (both heat sealed and mechanically sealed) remain integral under these conditions.
- 8.138 Acceptance criteria should be established and implemented for SUS corresponding to the risks or criticality of the product and its processes. Upon receipt, each piece of an SUS should be checked to ensure that they have been manufactured, supplied and delivered in accordance with the approved specification. A visual inspection of the outer packaging (including appearance of exterior carton and product pouches) and label printing and review of attached documents (such as a certificate of conformance and proof of sterilization) should be carried out and documented prior to use.
- 8.139 The critical manual handling operations of SUS, such as assembly and connections, should be subject to the appropriate controls and verified during APS.

9. Environmental and process monitoring

General

- 9.1 The site's environmental and process monitoring programme forms part of the overall CCS and is used to monitor the controls designed to minimize the risk of microbial and particle contamination. It should be noted that the reliability of each of the elements of the monitoring system (viable, non-viable and APS) when taken in isolation is limited and should not be considered individually to be an indicator of asepsis. When considered together, the results help confirm the reliability of the design, validation and operation of the system that they are monitoring.
- 9.2 This programme typically comprises the following elements:
- i. environmental monitoring – total particle
 - ii. environmental and personnel monitoring – viable particle
 - iii. temperature, relative humidity and other specific characteristics
 - iv. APS (aseptically manufactured product only).
- 9.3 The information from these systems should be used for routine batch certification and release and for periodic assessment during process review or investigation. This applies for both terminal sterilization and aseptic processes; however, the criticality of the impact may differ depending upon the product and process type.

Environmental and process monitoring

- 9.4 An environmental monitoring programme should be established and documented. The purpose of the environmental monitoring programme is to:
- i. provide assurance that cleanrooms and clean air equipment continue to provide an environment of appropriate air cleanliness, in accordance with design and regulatory requirements;
 - ii. effectively detect excursions from environmental limits triggering investigation and assessment of risk to product quality.

Risk assessments should be performed in order to establish this comprehensive environmental monitoring programme, such as sampling locations, frequency of monitoring, monitoring methods and incubation conditions (such as time, temperature, and aerobic or anaerobic conditions).

These risk assessments should be conducted based on detailed knowledge of the process inputs and final product, the facility, equipment, the criticality of specific processes and steps, the operations involved, routine monitoring data, monitoring data obtained during qualification and knowledge of typical microbial flora isolated from the environment.

The risk assessment should include the determination of critical monitoring locations – those locations where the presence of microorganisms during processing may have an impact upon product quality (for example, grade A aseptic processing areas and grade B areas that directly interface with grade A areas). Consideration of other information, such as air visualization studies, should also be included. These risk assessments should be reviewed regularly in order to confirm the effectiveness of the site's environmental monitoring programme. The monitoring programme should be considered in the overall context of the trend analysis and the CCS for the site.

- 9.5 The routine monitoring of cleanrooms, clean air equipment and personnel should be performed in operation throughout all critical stages of processing, including equipment set-up.
- 9.6 Other characteristics, such as temperature and relative humidity, should be controlled within ranges that align with product, processing and personnel requirements and support maintenance of defined cleanliness standards (for example, grades A or B).
- 9.7 The monitoring of grade A should demonstrate the maintenance of aseptic processing conditions during critical operations. Monitoring should be performed at locations posing the highest risk of contamination of the sterile equipment surfaces, containers, closures and product. The selection of monitoring locations and the orientation and positioning of sampling devices should be justified and appropriate to obtain reliable data from the critical zones.
- 9.8 Sampling methods should not pose a risk of contamination of the manufacturing operations.
- 9.9 The appropriate alert limits and action limits should be set for the results of viable and total particle monitoring. The maximum total particle action limits are described in Table.5 and the maximum viable particle action limits are described in Table.6. However, more stringent action limits may be applied based on data trending or the nature of the process, or as determined within the CCS. Both viable and total particle alert levels should be established based on results of cleanroom qualification tests and periodically reviewed based on ongoing trend data.

- 9.10 Alert limits for grade A (total particle only), grade B, grade C and grade D should be set such that adverse trends (for example, a number of events or individual events that indicate a deterioration of environmental control) are detected and addressed.
- 9.11 Monitoring procedures should define the approach to trending. Trends should include:
- i. increasing numbers of excursions from alert limits and action limits;
 - ii. consecutive excursions from alert limits;
 - iii. regular but isolated excursion from action limits that may have a common cause (for example, single excursions that always follow planned preventive maintenance);
 - iv. changes in microbial flora type and numbers and predominance of specific organisms, paying particular attention to organisms recovered that may indicate a loss of control or deterioration in cleanliness or organisms that may be difficult to control, such as spore-forming microorganisms and moulds.
- 9.12 The monitoring of grade C and D cleanrooms in operation should be performed based on data collected during qualification and routine data to allow effective trend analysis. The requirements of alert limits and action limits will depend on the nature of the operations carried out. Action limits may be more stringent than those listed in Tables.5 and.6 below.
- 9.13 If alert limits are exceeded, operating procedures should prescribe assessment and follow up, which should include consideration of an investigation or corrective actions to avoid any further deterioration of the environment. If action limits are exceeded, operating procedures should prescribe a root cause investigation, an assessment of the potential impact to product (including batches produced between the monitoring and reporting) and requirements for corrective and preventive action.

Environmental monitoring: total particle

- 9.14 A total particle monitoring programme should be established to obtain data for assessing potential contamination risks and to ensure the maintenance of the environment for sterile operations in a qualified state.
- 9.15 The limits for environmental monitoring of airborne particle concentration for each graded area are given in Table. 5.

Table. 5
Maximum permitted total particle concentration for monitoring

Grade	Maximum limits for total particle $\geq 0.5 \mu\text{m}/\text{m}^3$		Maximum limits for total particle $\geq 5 \mu\text{m}/\text{m}^3$	
	At rest	In operation	At rest	In operation
A	3 520	3 520	29	29
B	3 520	352 000	29	2 930
C	352 000	3 520 000	2 930	29 300
D	3 520 000	Not predetermined ^a	29 300	Not predetermined ^a

^a For grade D, in operation limits are not predetermined. The manufacturer should establish in operation limits based on a risk assessment and on routine data, where applicable.

Note 1: The particle limits given in the table for the at rest state should be achieved after a short clean-up period defined during qualification (guidance value of less than 20 minutes) in an unmanned state, after the completion of operations (refer to paragraph 4.29).

Note 2: The occasional indication of macro particle counts, especially $\geq 5 \mu\text{m}$, within grade A may be considered to be false counts due to electronic noise, stray light, coincidence loss, or other factor. However, consecutive or regular counting of low levels may be indicative of a possible contamination event and should be investigated. Such events may indicate early failure of the room air supply filtration system or equipment failure, or may be diagnostic of poor practices during machine set-up and routine operation.

- 9.16 For grade A, particle monitoring should be undertaken for the full duration of critical processing, including equipment assembly.
- 9.17 The grade A area should be monitored continuously (for particles ≥ 0.5 and $\geq 5 \mu\text{m}$) and with a suitable sample flow rate (at least 28 litres per minute) so that all interventions, transient events and any system deterioration is captured. The system should frequently correlate each individual sample result with alert levels and action limits at such a frequency that any potential excursion can be identified and responded to in a timely manner. Alarms should be triggered if alert levels are exceeded. Procedures should define the actions to be taken in response to alarms, including the consideration of additional microbial monitoring.
- 9.18 It is recommended that a similar system be used for the grade B area, though the sampling frequency may be decreased. The grade B area should be monitored at such a frequency and with suitable sample size that the programme captures any increase in levels of contamination and system deterioration. If alert limits are exceeded, alarms should be triggered.
- 9.19 The selection of the monitoring system should take into account any risk presented by the materials used in the manufacturing operation (for example,

those involving live organisms, powdery products or radiopharmaceuticals) that may give rise to biological, chemical or radiation hazards.

- 9.20 In the case where contaminants are present due to the processes involved, and would potentially damage the particle counter or present a hazard (for example, live organisms, powdery products and radiation hazards), the frequency and strategy employed should be appropriate to assure the environmental classification both prior to and post exposure to the risk. An increase in viable particle monitoring should be considered to ensure comprehensive monitoring of the process. Additionally, monitoring should be performed during simulated operations. Such operations should be performed at appropriate intervals. The approach should be defined in the CCS.
- 9.21 The size of monitoring samples taken using automated systems will usually be a function of the sampling rate of the system used. It is not necessary for the sample volume to be the same as that used for formal classification of cleanrooms and clean air equipment. Monitoring sample volumes should be justified.

Environmental and personnel monitoring: viable particle

- 9.22 Where aseptic operations are performed, microbial monitoring should be frequent using a combination of methods such as settle plates, volumetric air sampling, glove, gown and surface sampling (for example, using swabs and contact plates). The method of sampling used should be justified within the CCS and should be demonstrated not to have a detrimental impact on grade A and B airflow patterns. Cleanroom and equipment surfaces should be monitored at the end of an operation.
- 9.23 Viable particle monitoring should also be performed within the cleanrooms when normal manufacturing operations are not occurring (for example, post disinfection, prior to start of manufacturing, upon completion of the batch and after a shutdown period), and in associated rooms that have not been used in order to detect potential incidents of contamination that may affect the controls within the cleanrooms. In case of an incident, additional sample locations may be used as a verification of the effectiveness of a corrective action (such as cleaning and disinfection).
- 9.24 Continuous viable air monitoring in grade A (for example, air sampling or settle plates) should be undertaken for the full duration of critical processing, including equipment (aseptic set-up) assembly and critical processing. A similar approach should be considered for grade B cleanrooms based

on the risk of impact on the aseptic processing. The monitoring should be performed in such a way that all interventions, transient events and any system deterioration would be detected and captured to alert any risk caused.

- 9.25 A risk assessment should evaluate the locations, type and frequency of personnel monitoring based on the activities performed and the proximity to critical zones. Monitoring should include sampling of personnel at periodic intervals during the process. Sampling of personnel should be performed in such a way that it will not compromise the process. Particular consideration should be given to monitoring personnel following involvement in critical interventions (at a minimum gloves, but may require monitoring of areas of gown as applicable to the process) and on each exit from the grade B cleanroom (gloves and gown). Where the monitoring of gloves is performed after critical interventions, outer gloves should be replaced prior to continuation of activity. Where the monitoring of gowns is required after critical interventions, each gown should be replaced before further activity in the cleanroom.
- 9.26 Microbial monitoring of personnel in the grade A and B areas should be performed. Where operations are manual in nature (such as aseptic compounding or filling), the increased risk should lead to enhanced emphasis placed on microbial monitoring of gowns and justified within the CCS.
- 9.27 Where monitoring is routinely performed by manufacturing personnel, this should be subject to regular oversight by the quality unit (refer also to paragraph 8.19).
- 9.28 The adoption of suitable alternative monitoring systems, such as rapid methods, should be considered by manufacturers in order to expedite the detection of microbiological contamination issues and to reduce the risk to product. These rapid and automated microbial monitoring methods may be adopted after validation has demonstrated their equivalency or superiority to the established methods.
- 9.29 Sampling methods and equipment used should be fully understood and procedures should be in place for the correct operation and interpretation of results obtained. Supporting data for the recovery efficiency of the sampling methods chosen should be available.
- 9.30 Action limits for viable particle contamination are shown in Table. 6.

Table 6

Maximum action limits for viable particle contamination

Grade	Air sample CFU/m ³	Settle plates (diam. 90 mm) CFU/4 hours ^a	Contact plates (diam. 55 mm) CFU/plate ^b	Glove print, incl. 5 fingers on both hands CFU/glove
A			No growth ^c	
B	10	5	5	5
C	100	50	25	–
D	200	100	50	–

CFU = colony-forming unit.

^a Settle plates should be exposed in grade A and B areas for the duration of operations (including equipment set-up) and changed as required after a maximum of 4 hours (exposure time should be based on validation including recovery studies, and should not have any negative effect on the suitability of the media used). For grade C and D areas, exposure time (with a maximum of 4 hours) and frequency should be based on quality risk management. Individual settle plates may be exposed for less than 4 hours.

^b Contact plate limits apply to equipment, room and gown surfaces within the grade A and B areas. Routine gown monitoring is not normally required for grade C and D areas, depending on their use.

^c It should be noted that for grade A, any growth should result in an investigation.

Note 1: It should be noted that the types of monitoring methods listed in the table above are examples and other methods can be used provided they meet the intent of providing information across the whole of the critical process where product may be contaminated (for example, aseptic line set-up, aseptic processing, filling and lyophilizer loading).

Note 2: Limits are applied using CFU throughout the document. If different or new technologies are used that present results in a manner different from CFU, the manufacturer should scientifically justify the limits applied and, where possible, correlate them to CFU.

9.31 Microorganisms detected in the grade A and grade B areas should be identified to species level and the potential impact of such microorganisms on product quality (for each batch implicated) and overall state of control should be evaluated. Consideration should also be given to the identification of microorganisms detected in grade C and D areas (for example, where action limits or alert levels are exceeded) or following the isolation of organisms that may indicate a loss of control or deterioration in cleanliness or that may be difficult to control, such as spore-forming microorganisms and moulds, and at a sufficient frequency to maintain a current understanding of the typical flora of these areas.

Aseptic process simulation

9.32 Periodic verification of the effectiveness of the controls in place for aseptic processing should include an aseptic process simulation (APS) (also known as media fill) using a sterile nutrient medium or surrogate in place of the

product. The APS should not be considered as the primary means to validate the aseptic process or aspects of the aseptic process. The effectiveness of the aseptic process should be determined through process design, adherence to the PQS and process controls, training, and evaluation of monitoring data. Selection of an appropriate nutrient medium or surrogate should be made based on the ability of the medium or surrogate to imitate physical product characteristics assessed to pose a risk to product sterility during the aseptic process. Where processing stages may indirectly impact the viability of any introduced microbial contamination (for example, aseptically produced semi-solids, powders, solid materials, microspheres, liposomes and other formulations where product is cooled or heated or lyophilized), alternative procedures that represent the operations as closely as possible should be developed. Where surrogate materials, such as buffers, are used in parts of the APS, the surrogate material should not inhibit the growth of any potential contamination.

- 9.33 The APS should imitate as closely as possible the routine aseptic manufacturing process and include all the critical manufacturing steps, specifically:
- i. The APS should cover all aseptic operations performed subsequent to the sterilization and decontamination cycles of materials utilized in the process to the point where the container is sealed.
 - ii. For non-filterable formulations, any additional aseptic steps should be covered.
 - iii. Where aseptic manufacturing is performed under an inert atmosphere, the inert gas should be substituted with air in the process simulation unless anaerobic simulation is intended.
 - iv. Processes requiring the addition of sterile powders should use an acceptable surrogate material in the same containers as those used in the process under evaluation.
 - v. Separate simulations of individual unit operations (for example, processes involving drying, blending, milling and subdivision of a sterile powder) should be avoided. Any use of individual simulations should be supported by a documented justification and ensure that the sum total of the individual simulations continues to fully cover the whole process.
 - vi. The process simulation procedure for lyophilized products should represent the entire aseptic processing chain, including filling, transport, loading, a representative duration of the chamber dwell, unloading and sealing under specified, documented and justified conditions representing worst-case operating parameters.

- vii. The lyophilization process simulation should mimic all aspects of the process, except those that may affect the viability or recovery of contaminants. For instance, boiling over or actual freezing of the solution should be avoided. Factors to consider in determining APS design include, where applicable:
- the use of air to break vacuum instead of nitrogen or other process gases;
 - replicating the maximum interval between sterilization of the lyophilizer and its use;
 - replicating the maximum period of time between filtration and lyophilization;
 - quantitative aspects of worst-case situations, for example, loading the largest number of trays, replicating the longest duration of loading where the chamber is open to the environment.
- 9.34 The APS should take into account various aseptic manipulations and interventions known to occur during normal production, as well as worst-case situations, and should take into account the following:
- i. Inherent and corrective interventions representative of the routine process should be performed in a manner and frequency similar to that during the routine aseptic process.
 - ii. The inclusion and frequency of interventions in the APS should be based on assessed risks posed to product sterility.
- 9.35 APS should not be used to justify practices that pose unnecessary contamination risks.
- 9.36 In developing the APS plan, consideration should be given to the following:
- i. Identification of worst-case conditions covering the relevant variables, such as container size and line speed, and their impact on the process. The outcome of the assessment should justify the variables selected.
 - ii. Determining the representative sizes of container or closure combinations to be used for validation. A bracketing or matrix approach may be considered for validation of the same container or closure configuration for different products where process equivalence is scientifically justified.
 - iii. Maximum permitted holding times for sterile product and equipment exposed during the aseptic process.

- iv. The volume filled per container, which should be sufficient to ensure that the medium contacts all equipment and component surfaces that may directly contaminate the sterile product. The volume used should provide sufficient headspace to support potential microbial growth and ensure that turbidity can be detected during inspection.
- v. The requirement for substitution of any inert gas used in the routine aseptic manufacturing process by air unless anaerobic simulation is intended. In these situations, inclusion of occasional anaerobic simulations as part of the overall validation strategy should be considered (refer to paragraph 9.33, point iii).
- vi. The selected nutrient medium should be capable of growing a designated group of reference microorganisms, as described by the relevant pharmacopoeia, and suitably representative local isolates.
- vii. The method of detection of microbial contamination should be scientifically justified to ensure that contamination is reliably detected.
- viii. The process simulation should be of sufficient duration to simulate the process, the operators that perform interventions, shift changes, and the capability of the processing environment to provide appropriate conditions for the manufacture of a sterile product.
- ix. Where the manufacturer operates different or extended shifts, the APS should be designed to capture factors specific to those shifts that are assessed to pose a risk to product sterility; for example, the maximum duration for which an operator may be present in the cleanroom.
- x. Simulating normal aseptic manufacturing interruptions where the process is idle (for example, shift changeovers, recharging dispensing vessels, introduction of additional equipment).
- xi. Ensuring that environmental monitoring is conducted as required for routine production, and throughout the entire duration of the process simulation.
- xii. Where campaign manufacturing occurs, as in the use of barrier technologies or manufacture of sterile active substances, consideration should be given to designing and performing the process simulation so that it simulates the risks associated with both the beginning and the end of the campaign and demonstrating that the campaign duration does not pose any risk.
- xiii. The performance of end of production or campaign APS may be used for additional assurance or investigative purposes; however, their use should be justified in the CCS and should not replace

routine APS. If used, it should be demonstrated that any residual product does not negatively impact the recovery of any potential microbial contamination.

- 9.37 For sterile active substances, batch size should be large enough to represent routine operation, simulate intervention operation at the worst case and cover all surfaces that may come into contact with the sterile product. In addition, all the simulated materials (surrogates or growth medium) should be subjected to microbial evaluation. The simulation materials should be sufficient to satisfy the evaluation of the process being simulated and should not compromise the recovery of microorganisms.
- 9.38 APS should be performed as part of the initial validation, with at least three consecutive satisfactory simulation tests that cover all working shifts that the aseptic process may occur in, and after any significant modification to operational practices, facilities, services or equipment that are assessed to have an impact on the sterility assurance of the product (such as modification to the HVAC system or equipment, changes to process, number of shifts and numbers of personnel, or major facility shutdown). Normally, APS (periodic revalidation) should be repeated twice a year (approximately every six months) for each aseptic process, each filling line and each shift. Each operator should participate in at least one successful APS annually. Consideration should be given to performing an APS after the last batch prior to shutdown, before long periods of inactivity or before decommissioning or relocation of a line.
- 9.39 Where manual operation (such as aseptic compounding or filling) occurs, each type of container, container closure and equipment train should be initially validated, with each operator participating in at least three consecutive successful APS and revalidated with one APS approximately every six months for each operator. The APS batch size should mimic that used in the routine aseptic manufacturing process.
- 9.40 The number of units processed (filled) for APS should be sufficient to effectively simulate all activities that are representative of the aseptic manufacturing process. Justification for the number of units to be filled should be clearly captured in the CCS. Typically, a minimum of 5000 to 10 000 units should be filled. For small batches (for example, those under 5000 units), the number of containers for APS should at least equal the size of the production batch.
- 9.41 Filled APS units should be agitated, swirled or inverted before incubation to ensure contact of the medium with all interior surfaces in the container. All integral units from the APS should be incubated and evaluated,

including units with cosmetic defects or those that have gone through non-destructive in-process control checks. If units are discarded during the process simulation and not incubated, these should be comparable with units discarded during a routine fill, and only if production standard operating procedures clearly specify that units must be removed under the same circumstances (that is, type of intervention, line location and specific number of units removed). In no case should more units be removed during an APS intervention than would be cleared during a production run. Examples may include those that must be discarded during routine production after the set-up process or following a specific type of intervention. To fully understand the process and assess contamination risks during aseptic set-up or mandatory line clearances, these units would typically be incubated separately, and would not necessarily be included in the acceptance criteria for the APS.

- 9.42 Where processes include materials that contact the product contact surfaces but are then discarded (such as product flushes), the discarded material should be simulated with nutrient media and be incubated as part of the APS unless it can be clearly demonstrated that this waste process would not impact the sterility of the product.
- 9.43 Filled APS units should be incubated in a clear container to ensure visual detection of microbial growth. Where the product container is not clear (such as amber glass or opaque plastic), clear containers of identical configuration may be substituted to aid in the detection of contamination. When a clear container of identical configuration cannot be substituted, a suitable method for the detection of microbial growth should be developed and validated. Microorganisms isolated from contaminated units should be identified to the species level when practical, to assist in the determination of the likely source of the contaminant.
- 9.44 Filled APS units should be incubated without delay to achieve the best possible recovery of potential contamination. The selection of the incubation conditions and duration should be scientifically justified and validated to provide an appropriate level of sensitivity of detection of microbial contamination.
- 9.45 On completion of incubation:
- i. Filled APS units should be inspected by personnel who have been appropriately trained and qualified for the detection of microbiological contamination. Inspection should be conducted under conditions that facilitate the identification of any microbial contamination.

- ii. Samples of the filled units should undergo positive control by inoculation with a suitable range of reference organisms and suitably representative local isolates.
- 9.46 The target should be zero growth. Any contaminated unit should result in a failed APS and the following actions should be taken.
- i. An investigation should be undertaken to determine the most probable root causes.
 - ii. Appropriate corrective measures should be determined and implemented.
 - iii. A sufficient number of successful, consecutive repeat APS (normally a minimum of three) should be conducted in order to demonstrate that the process has been returned to a state of control.
 - iv. A prompt review should be made of all appropriate records relating to aseptic production since the last successful APS:
 - The outcome of the review should include a risk assessment of potential sterile breaches in batches manufactured since the last successful APS.
 - All other batches not released to the market should be included in the scope of the investigation. Any decision regarding their release status should consider the investigation outcome.
 - v. All products that have been manufactured on a line subsequent to a process simulation failure should be quarantined until a successful resolution of the process simulation failure has occurred.
 - vi. Where the root cause investigation indicates that the failure was related to operator activity, actions to limit the operator's activities, until retrained and requalified, should be taken.
 - vii. Production should resume only after completion of successful revalidation.
- 9.47 All APS runs should be fully documented and include a reconciliation of units processed (such as units filled, incubated and not incubated). The justification for filled and non-incubated units should be included in the documentation. All interventions performed during the APS should be recorded, including the start and end time of each intervention and the involved person. All microbial monitoring data, as well as other testing data, should be recorded in the APS batch record.

- 9.48 An APS run should be aborted only under circumstances in which written procedures require commercial lots to be equally handled. An investigation should be documented in such cases.
- 9.49 An aseptic process should be subject to a repeat of the initial validation when:
- i. the specific aseptic process has not been in operation for an extended period of time;
 - ii. there is a change to the process, equipment, procedures or environment that has the potential to affect the aseptic process or an addition of new product containers or container-closure combinations.
- 9.50 Routine production, after completion of the APS, should only commence after validated procedures have been completed in accordance with the CCS, to ensure that there is no risk to the product.

10. Quality control

Note: This section mainly focuses on some aspects of microbiological control. See also *WHO good practices for pharmaceutical microbiology laboratories* (Annex 2, WHO Technical Report Series 961, 2011) and relevant pharmacopoeia.

- 10.1 There should be a sufficient number of personnel available with appropriate training and experience in microbiology, sterility assurance and knowledge of the processes to support the design of the manufacturing activities, environmental monitoring regime and any investigation needed to assess the impact of microbiologically linked events on the quality and safety of the sterile product.
- 10.2 Specifications for raw materials, components and products should include requirements for microbial, particulate and endotoxin/pyrogen limits when the need for this has been indicated by monitoring or by the CCS.
- 10.3 The bioburden assay should be performed on each batch for both aseptically filled product and terminally sterilized products and the results considered as part of the final batch review. There should be defined limits for bioburden immediately before the final sterilizing grade filter or the terminal sterilization process, which are related to the efficiency of the method to be used. Samples should be taken to be representative of the worst-case scenario (for example, at the end of hold time). Where overkill sterilization parameters are set for terminally sterilized products, bioburden should be monitored at suitable scheduled intervals.

- 10.4 For products authorized for parametric release, a supporting presterilization bioburden monitoring programme for the filled product prior to initiating the sterilization cycle should be developed and the bioburden assay should be performed for each batch. The sampling locations of filled units before sterilization should be based on a worst-case scenario and be representative of the batch. Any organisms found during bioburden testing should be identified and their impact on the effectiveness of the sterilizing process determined. Where appropriate, the level of endotoxin/pyrogen should be monitored.
- 10.5 The sterility test applied to the finished product should only be regarded as the last in a series of critical control measures by which sterility is assured. It cannot be used to assure sterility of a product that does not meet its design, procedural or validation parameters. The test should be validated for the product concerned.
- 10.6 The sterility test should be performed under aseptic conditions. Samples taken for sterility testing should be representative of the whole of the batch but should, in particular, include samples taken from parts of the batch considered to be most at risk of contamination, for example:
- i. For products that have been filled aseptically, samples should include containers filled at the beginning and end of the batch. Additional samples (for example, taken after critical interventions) should be considered based on risk.
 - ii. For products that have been heat sterilized in their final containers, samples taken should be representative of the worst-case locations (for example, the potentially coolest or slowest to heat part of each load).
 - iii. For products that have been lyophilized, samples should be taken from different lyophilization loads.

Note: Where the manufacturing process results in sub-batches (for example, for terminally sterilized products), then sterility samples from each sub-batch should be taken and a sterility test for each sub-batch performed. (Consideration should also be given to performing separate testing for the other parameters of the product.)

- 10.7 For some products, it may not be possible to obtain a sterility test result prior to release because the shelf-life of the product is too short to allow completion of a sterility test. In these cases, the additional considerations of design of the process and additional monitoring or alternative test methods required to mitigate the identified risks should be assessed and documented.

- 10.8 Any substance or process (for example, vaporized hydrogen peroxide, ultraviolet) used to decontaminate the external surfaces of sterility samples prior to testing should not negatively impact the sensitivity of the test method or the reliability of the outcome of the test.
- 10.9 Media used for product testing should be quality control tested according to the relevant pharmacopoeia before use. Media used for environmental monitoring and APS should be tested for growth promotion before use, using a scientifically justified and designated group of reference microorganisms and including suitably representative in-house isolates. Media quality control testing should normally be performed by the end user. Any reliance on outsourced testing or supplier testing of media should be justified and transportation and shipping conditions should be thoroughly considered in this case.
- 10.10 Environmental monitoring data and trend data generated for classified areas should be reviewed as part of product batch certification and release. A written procedure should be available that describes the actions to be taken when data from environmental monitoring are found out of trend or exceeding the established limits. For products with a short shelf-life, the environmental data for the time of manufacture may not be available; in these cases, the compliance should include a review of the most recent available data. Manufacturers of these products should consider the use of rapid or alternative methods.
- 10.11 Rapid and automated microbial methods should be validated.

Glossary

action limit. An established relevant measure (for example, microbial or airborne particle limits) that, when exceeded, should trigger appropriate investigation and corrective action based on the investigation.

airlock. An enclosed space with interlocked doors, constructed to maintain air pressure control between adjoining rooms (generally with different air cleanliness standards). The intent of an airlock is to preclude ingress of particle matter and microorganism contamination from a less controlled area.

alert level. An established relevant measure (such as microbial or airborne particle levels) giving early warning of potential drift from normal operating conditions and validated state, which does not necessarily give grounds for corrective action but triggers appropriate scrutiny and follow-up to address the potential problem. Alert levels are established based on routine and qualification

trend data and are periodically reviewed. The alert level can be based on a number of parameters, including adverse trends, individual excursions above a set limit and repeat events.

asepsis. A state of control attained by using an aseptic work area and performing activities in a manner that precludes microbial contamination of the exposed sterile product.

aseptic preparation or processing. The handling of sterile product, containers or devices in a controlled environment in which the air supply, materials and personnel are regulated to prevent microbial, endotoxin/pyrogen and particle contamination.

aseptic process simulation (APS). A simulation of the entire aseptic manufacturing process in order to verify the capability of the process to ensure product sterility. APS includes all aseptic operations associated with routine manufacturing (for example, equipment assembly, formulation, filling, lyophilization and sealing processes, as necessary).

bacterial retention testing. This test is performed to validate that a filter can remove bacteria from a gas or liquid. The test is usually performed using a standard organism, such as *Brevundimonas diminuta*, at a minimum concentration of 10^7 colony-forming units/cm².

barrier. A physical partition that affords aseptic processing area (usually grade A) protection by separating it from the background environment. Such systems frequently use in part or totally the barrier technologies known as RABS (restricted access barrier systems) or isolators.

bioburden. The total number of microorganisms associated with a specific item, such as personnel, manufacturing environments (air and surfaces), equipment, product packaging, raw materials (including water), in-process materials or finished products.

biodecontamination. A process that eliminates viable bioburden via the use of sporicidal chemical agents.

biological indicator. A population of microorganisms inoculated onto a suitable medium (for example, solution, container or closure) and placed within a sterilizer or load or room location to determine the sterilization or disinfection cycle efficacy of a physical or chemical process. The challenge microorganism is selected and validated based upon its resistance to the given process. Incoming lot D-value, microbiological count and purity define the quality of the biological indicator.

blow-fill-seal (BFS). A technology in which containers are formed from a thermoplastic granulate, filled with product, and then sealed in a continuous, integrated, automatic operation. The two most common types of BFS machines are the shuttle type (with parison cut) and the rotary type (closed parison).

campaign manufacture. The manufacture of a series of batches of the same product in sequence in a given period of time with strict adherence to established and validated control measures.

classified area. An area that contains a number of cleanrooms [see also cleanroom definition].

clean area. An area with defined particle and microbiological cleanliness standards, usually containing a number of joined cleanrooms.

cleaning. A process for removing contamination (for example, product residues or disinfectant residues).

cleanroom. A room designed, maintained and controlled to prevent particle and microbial contamination of drug products. Such a room is assigned and reproducibly meets an appropriate air cleanliness level.

cleanroom classification. A method of assessing the level of air cleanliness against a specification for a cleanroom or clean air equipment by measuring the total particle concentration.

cleanroom qualification. A method of assessing the level of compliance of a classified cleanroom or clean air equipment with its intended use.

closed system. A system in which the product is not exposed to the surrounding environment. For example, this can be achieved by the use of bulk product holders (such as tanks or bags) that are connected to each other by pipes or tubes as a system. Where used for sterile products, the full system is sterilized after the connections are made. Examples of these can be large-scale reusable systems, such as those seen in active substance manufacturing, or disposable bag and manifold systems, such as those seen in the manufacture of biological products. Closed systems are not opened until the conclusion of an operation. The use of the term “closed systems” in this guideline does not refer to systems such as RABS or isolator systems.

colony-forming unit (CFU). A microbiological term that describes a single detectable colony that originates from one or more microorganisms. CFUs are typically expressed as CFU per millilitre (mL) for liquid samples, CFU per square metre (m²) for air samples and CFU per sample for samples captured on solid medium, such as settle or contact plates.

contamination. The undesired introduction of impurities of a microbiological nature (quantity and type of microorganisms, pyrogen) or of foreign particle matter into or onto a raw material, intermediate, active substance or drug product during production, sampling, packaging or repackaging, storage or transport with the potential to adversely impact product quality.

contamination control strategy (CCS). A planned set of controls for microorganisms, endotoxin/pyrogen and particles, derived from current product and process understanding, that assures process performance and product quality. The controls can include parameters and attributes related to active substance, excipient and drug product materials and components, facility and equipment operating conditions, in-process controls, finished product specifications, and the associated methods and frequency of monitoring and control.

corrective intervention. An intervention that is performed to correct or adjust an aseptic process during its execution. This may not occur at a set frequency in the routine aseptic process. Examples include clearing component jams, stopping leaks, adjusting sensors and replacing equipment components.

critical intervention. An intervention (corrective or inherent) into the critical zone.

critical surface. A surface that may come directly into contact with, or directly affect, a sterile product or its containers or closures. Critical surfaces are rendered sterile prior to the start of the manufacturing operation and sterility is maintained throughout processing.

critical zone. A location within the aseptic processing area in which product and critical surfaces are exposed to the environment.

dead leg. Length of non-circulating pipe (where fluid may remain static) that is greater than three internal pipe diameters.

decommission. To close and remove from use a process, equipment or cleanroom.

decontamination. The overall process of removal or reduction of any contaminants (chemical, waste, residue or microorganisms) from an area, object or person. The method of decontamination used (for example, cleaning, disinfection, sterilization) should be chosen and validated to achieve a level of cleanliness appropriate to the intended use of the item decontaminated [see also biodecontamination].

depyrogenation. A process designed to remove or inactivate pyrogenic material (such as endotoxin) to a specified minimum quantity.

disinfection. The process by which a reduction of the number of microorganisms is achieved by the irreversible action of a product on their structure or metabolism to a level deemed to be appropriate for a defined purpose.

D-value. The value of a parameter of sterilization (duration or absorbed dose) required to reduce the number of viable organisms to 10% of the original number.

endotoxin. A pyrogenic product (lipopolysaccharide) present in the Gram-negative bacterial cell wall. Endotoxin can lead to reactions in patients receiving injections ranging from fever to death.

equilibration time. The period that elapses between the attainment of the sterilization temperature at the reference measurement point and the attainment of the sterilization temperature at all points within the load.

extractable. A chemical entity that migrates from the surface of the process equipment, exposed to an appropriate solvent at extreme conditions, into the product or material being processed.

filter integrity test. A test to confirm that a filter (product, gas, or heating, ventilation and air-conditioning (HVAC) filter) retains its retentive properties and has not been damaged during handling, installation or processing.

first air. Filtered air that has not been interrupted prior to contacting exposed product and product contact surfaces with the potential to add contamination to the air prior to reaching the critical zone.

form-fill-seal (FFS). An automated filling process, typically used for terminally sterilized products, that constructs the primary container out of a continuous flat roll of packaging film while simultaneously filling the formed container with product and sealing the filled containers in a continuous process. FFS processes may utilize a single web system (whereby a single flat roll of film is wrapped around itself to form a cavity) or a dual web system (whereby two flat rolls of film are brought together to form a cavity), often with the aid of vacuum moulds or pressurized gases. The formed cavity is filled, sealed and cut into sections. Films typically consist of a polymeric material, polymeric coated foil or other suitable material.

gowning qualification. A programme that establishes, both initially and on a periodic basis, the capability of an individual to don the complete gown.

grade A air supply. Air that is passed through a filter qualified as capable of producing grade A total particle quality air, but where there is no requirement to perform continuous total particle monitoring or meet grade A viable monitoring

limits. Specifically used for the protection of fully stoppered vials where the cap has not yet been crimped.

high-efficiency particulate air (HEPA) filter. A high-efficiency particulate air filter specified in accordance with a relevant international standard.

inherent intervention. An intervention that is an integral part of the aseptic process and is required for set-up, routine operation or monitoring (for example, aseptic assembly, container replenishment or environmental sampling). Inherent interventions are required by procedure or work instruction for the execution of the aseptic process.

intrinsic sterile connection device. A device that reduces the risk of contamination during the connection process. The device can be mechanical or fusion sealing.

isokinetic sampling head. A sampling head designed to disturb the air as little as possible so that the same particles go into the nozzle as would have passed the area if the nozzle had not been there (that is, the sampling condition in which the mean velocity of the air entering the sample probe inlet is nearly the same ($\pm 20\%$) as the mean velocity of the airflow at that location).

isolator. An enclosure capable of being subject to reproducible interior biodecontamination, with an internal work zone meeting grade A conditions that provide uncompromised continuous isolation of its interior from the external environment (for example, surrounding cleanroom air and personnel). There are two major types of isolators:

- Closed isolator systems exclude external contamination of the isolator's interior by accomplishing material transfer via aseptic connection to auxiliary equipment rather than use of openings to the surrounding environment. Closed systems remain sealed throughout operations.
- Open isolator systems are designed to allow for the continuous or semicontinuous ingress or egress of materials during operations through one or more openings. Openings are engineered (for example, using continuous overpressure) to exclude the entry of external contaminant into the isolator.

leachable. A chemical entity that migrates into a product from the product contact surface of the process equipment or containers under normal condition of use or storage.

local isolates. Suitably representative microorganisms of the site that are frequently recovered through environmental monitoring within the classified

zone or areas (especially grade A and B areas), personnel monitoring, or positive sterility test results.

lyophilization. A physical-chemical drying process designed to remove solvents, by way of sublimation, from both aqueous and non-aqueous systems, primarily to achieve product or material stability. Lyophilization is synonymous with the term “freeze-drying”.

manual aseptic processing. An aseptic process whereby the operator manually compounds, fills, places or seals an open container with sterile product.

operator. Any individual participating in the processing operation, including line set-up, filling, maintenance or other personnel associated with manufacturing activities.

overkill sterilization. A process that is sufficient to provide at least a $12 \log_{10}$ reduction of microorganisms having a minimum D-value of 1 minute.

parison. The “tube” of polymer extruded by the BFS machine from which containers are formed.

pass-through hatch. Synonymous with airlock [refer to airlock definition] but typically smaller in size.

patient. Human or animal participant in a clinical trial.

post-aseptic processing terminal heat treatment. A terminal moist heat process employed after aseptic processing that has been demonstrated to provide a sterility assurance level of $\leq 10^{-6}$ but where the requirements of steam sterilization (for example, $F_0 \geq 8$ minutes) are not fulfilled. This may also be beneficial in the destruction of viruses that may not be removed through filtration.

pyrogen. A substance that induces a febrile reaction in patients receiving injections.

rapid transfer system or port. A system used for the transfer of items into RABS or isolators that minimizes the risk to the critical zone. An example would be a rapid transfer container with an alpha/beta port.

raw material. Any ingredient intended for use in the manufacture of a sterile product, including those that may not appear in the final drug product.

restricted access barrier system (RABS). A system that provides an enclosed, but not fully sealed, environment meeting defined air quality conditions (for aseptic processing grade A) and using a rigid wall enclosure and integrated gloves to separate its interior from the surrounding cleanroom environment. The

inner surfaces of the RABS are disinfected and decontaminated with a sporicidal agent. Operators use gloves, half suits, rapid transfer systems or ports, and other integrated transfer ports to perform manipulations or convey materials to the interior of the RABS. Depending on the design, doors are rarely opened and only under strictly predefined conditions.

single-use system (SUS). A system in which product contact components are used only once to replace reusable equipment such as stainless steel transfer lines or bulk containers. Single-use systems covered in this document are those that are used in manufacturing processes of sterile products and are typically made up of disposable components such as bags, filters, tubing, connectors, storage bottles and sensors.

sporicidal agent. An agent that destroys bacterial and fungal spores when used in sufficient concentration for a specified contact time. It is expected to kill all vegetative microorganisms.

sterile product. For the purpose of this guidance, sterile product refers to one or more of the sterilized elements exposed to aseptic conditions and, ultimately, making up the sterile active substance or finished sterile product. These elements include the containers, closures and components of the finished drug product. Or, a product that is rendered sterile by a terminal sterilization process.

sterilizing grade filter. A filter that, when appropriately validated, will remove a defined microbial challenge from a fluid or gas producing a sterile effluent. Usually such filters have a pore size equal to or less than 0.22 micrometres (μm).

terminal sterilization. The application of a lethal sterilizing agent or conditions to a product in its final container to achieve a predetermined sterility assurance level of 10^{-6} or better (that is, the theoretical probability of there being a single viable microorganism present on or in a sterilized unit is equal to or less than 1×10^{-6} , or 1 in a million).

turbulent airflow. Air that is not unidirectional. Turbulent air in cleanrooms should flush the cleanroom via a mixed flow dilution and ensure maintenance of acceptable air quality.

unidirectional airflow. An airflow moving in a single direction in a robust and uniform manner and at sufficient speed to reproducibly sweep particles away from the critical processing or testing area.

unidirectional airflow unit. A cabinet supplied with filtered unidirectional airflow (previously referred to as a laminar airflow unit).

worst case. A set of conditions encompassing processing limits and circumstances, including those within standard operating procedures, that pose the greatest chance of process or product failure (when compared with ideal conditions). Such conditions have the highest potential to, but do not necessarily always, result in product or process failure.

water system. A system for producing, storing and distributing water, usually compliant with a specific pharmacopoeia grade (for example, purified water and water for injection).

Z-value. The temperature difference that leads to a 10-fold change in the D-value of the biological indicator.

Further reading

- WHO good practices for pharmaceutical microbiology laboratories. In: WHO Expert Committee on Specifications for Pharmaceutical Preparations: forty-fifth report. WHO Technical Report Series No. 961, Annex 2. Geneva: World Health Organization; 2011 (<https://apps.who.int/iris/handle/10665/44079>).
- WHO good manufacturing practices for pharmaceutical products: main principles. In: WHO Expert Committee on Specifications for Pharmaceutical Preparations: forty-eighth report. WHO Technical Report Series No. 986, Annex 2. Geneva: World Health Organization; 2014 (<https://apps.who.int/iris/handle/10665/112733>).
- Guidelines on heating, ventilation and air-conditioning systems for non-sterile pharmaceutical products. In: WHO Expert Committee on Specifications for Pharmaceutical Preparations: fifty-second report. WHO Technical Report Series No. 1010, Annex 8. Geneva: World Health Organization; 2018 (<https://apps.who.int/iris/handle/10665/272452>).
- Good manufacturing practices: guideline on validation. In: WHO Expert Committee on Specifications for Pharmaceutical Preparations: fifty-third report. WHO Technical Report Series No. 1019, Annex 3. Geneva: World Health Organization; 2019 (<https://apps.who.int/iris/handle/10665/312316>).
- Production of water for injection by means other than distillation. In: WHO Expert Committee on Specifications for Pharmaceutical Preparations: fifty-fourth report. WHO Technical Report Series No. 1025, Annex 3. Geneva: World Health Organization; 2020 (<https://apps.who.int/iris/handle/10665/331814>).
- Water for injections [Aqua pro injection]. In: The International Pharmacopoeia, tenth edition. Geneva: World Health Organization; 2020 (<https://digicollections.net/phint/2020/index.html#d/b.6.1.364>).
- Good manufacturing practices: water for pharmaceutical use. In: WHO Expert Committee on Specifications for Pharmaceutical Preparations: fifty-fifth report. WHO Technical Report Series No. 1033, Annex 3. Geneva: World Health Organization; 2021 (<https://apps.who.int/iris/handle/10665/340323>).
- ISO 14644 series of standards. Geneva: International Organization for Standardization (<https://www.iso.org/search.html?q=ISO%2014644>).

Annex 3

IAEA/WHO guideline on good manufacturing practices for investigational radiopharmaceutical products

Background

In view of the rapidly expanding field of molecular imaging and targeted radiopharmaceutical therapy, combined with the absence of dedicated guidance specific to the manufacture of investigational radiopharmaceuticals used in both early and late clinical trials, the World Health Organization (WHO), in partnership with the International Atomic Energy Agency (IAEA), has raised the urgency for the generation of a new *IAEA/WHO guideline on good manufacturing practices for investigational radiopharmaceutical products*.

The objective of this guideline is to meet current expectations and trends in good manufacturing practices specific to investigational radiopharmaceuticals used in clinical trials (that is, phase I, phase II and phase III trials) and to harmonize the text with the principles from other related international guidelines.

This text was developed in alignment with the *Good manufacturing practices; supplementary guidelines for the manufacture of investigational pharmaceutical products for clinical trials in humans (1)*. A draft working document was made available online for comments (2).

Contents

Background	171
1. Introduction	173
2. Scope	175
3. Glossary	175
4. Quality management	178
5. Quality risk management	179
6. Personnel	180
7. Documentation	181
7.1 Specifications	182
7.2 Manufacturing formulae and processing instructions	183
7.3 Batch manufacturing records	183

8. Premises	183
9. Equipment and utilities	185
10. Materials	185
10.1 Starting materials	185
10.2 Reference standards for analytical purposes	186
11. Production	186
11.1 Manufacturing operations	187
11.2 Packaging and labelling	188
12. Quality control	189
13. Qualification and validation	190
14. Complaints	192
15. Recalls	192
16. Returns	193
17. Shipping	193
18. Destruction	194
References	194

1. Introduction

- 1.1 Radiopharmaceuticals are rapidly re-emerging as clinically valuable tools used in the diagnosis and treatment of various types of disease. Molecular imaging agents offer unparalleled methodology not only to help elucidate the presence and the extent of disease but also to help characterize the disease, select specific patients for a particular therapy and evaluate a treatment response. Additionally, novel targeted radioligand therapies offer alternatives to patients for whom no other treatment options exist.
- 1.2 This rapid expansion has been accompanied by a set of challenges due to the complexity and unique nature of these agents. One of the main challenges associated with novel radiopharmaceutical development is how to define the proper balance with respect to the controls required when conducting early clinical studies of manufacture of investigational radiopharmaceuticals, and the subsequent implementation of additional controls as the radiopharmaceutical is developed further into pivotal phase III trials. Having inadequate manufacturing controls during early clinical evaluations either carries the risks of unnecessary patient harm or jeopardizes the validity of the collected study results. On the other hand, redundant manufacturing controls, particularly in the initial stages of development, carry the risk of slowing the pace of clinical development of potentially lifesaving therapies. This risk is further intensified by other factors such as the high costs and lengthy time associated with the actual clinical conduct of the study, the completion of the preclinical evaluation of the agent, and the low probability of successful marketing approval. In light of these challenges, a balanced approach with respect to manufacturing process controls is essential, as the degree of manufacturing process controls is correlated with the particular stage of radiopharmaceutical development, the nature of the agent itself, and the clinical study goals.
- 1.3 This guidance provides recommendations on the minimum standards that should be in place when preparing novel radiopharmaceuticals for phases I–III clinical investigations that do not have a marketing authorization.
- 1.4 Investigational radiopharmaceuticals are used for testing purposes, as a reference in a clinical trial for an unauthorized indication, and to gain further information about the authorized form.
- 1.5 Depending on the country, these products are sometimes not covered by legal and regulatory provisions in the areas of good manufacturing practices (GMP). The lack of both high-level GMP requirements and prior knowledge of the risk of contamination and cross-contamination

of products contributes to the risk of using them in human subjects. In addition, the risk may be further increased in cases of incomplete knowledge of the potency, human biodistribution, and toxicity of the investigational radiopharmaceuticals.

- 1.6 To minimize the risks and to ensure that the results of clinical trials are unaffected by inadequate safety, quality or efficacy arising from unsatisfactory production, investigational radiopharmaceuticals should be produced and managed in accordance with an effective quality management system and the recommendations contained in this guideline.
- 1.7 Procedures should be flexible to allow for changes whenever necessary through a properly controlled and traceable change management system, as knowledge of the process increases in accordance with the stages of development of the product.
- 1.8 Investigational radiopharmaceuticals should be produced in a manner that is compliant with GMP requirements that are specific to the particular stage of agent development.
- 1.9 As the clinical development of radiopharmaceutical progresses from phases I–II to the pivotal phase III and commercial stage, additional manufacturing process controls and analytical method validation should be implemented so as to ensure:
 - that subjects of clinical trials will be protected from poor-quality products due to unsatisfactory manufacturing;
 - that consistency exists between and within batches of the investigational radiopharmaceuticals;
 - that consistency exists between the investigational product and the future commercial product.
- 1.10 The selection of an appropriate dosage form for clinical trials is important. While it is accepted that the dosage form in early trials may be different from the anticipated final formulation (for example, different strength or different buffers, radiostabilizers and other excipients), in the pivotal phase III studies it should be equivalent to the projected commercial presentation in terms of the expected biodistribution profile. If there are significant differences between the investigational and commercial dosage forms, data should be submitted to the registration authorities to demonstrate that the final dosage form is equivalent, in terms of biodistribution and stability, to that used in the clinical trials.

- 1.11 The quality of investigational radiopharmaceuticals should be appropriate for the particular stage of development. For example, it should be feasible to apply only the critical manufacturing controls for agents in phase I and phase II trials, while the manufacture of investigational radiopharmaceuticals for phase III clinical studies should generally have the same degree of applied controls as for commercial manufactured products.
- 1.12 This document should be read in conjunction with other World Health Organization (WHO) GMP guidelines, including good clinical practices, good documentation practices and International Atomic Energy Agency (IAEA) radiation protection documents related to radiopharmaceuticals (3–9).

2. Scope

- 2.1 The recommendations in this guideline are applicable to investigational radiopharmaceutical products for human use.
- 2.2 The recommendations of this guideline do not apply to radiopharmaceuticals in phase IV (with marketing authorization) that already have regulatory authority approval for a certain indication but might be used to conduct a clinical study for a different indication. In those situations, the IAEA/WHO guideline on GMP for radiopharmaceutical products should be used (3).

3. Glossary

The definitions given below apply to the terms used in this guideline. They may have different meanings in other contexts.

active pharmaceutical ingredient. With respect to radiopharmaceutical preparations, the active pharmaceutical ingredient is the radioactive molecule that is responsible for the radiopharmaceutical mechanism of action. This active pharmaceutical ingredient may be in the form of the radionuclide by itself, if its use by itself is clinically indicated, or in the form of a radionuclide coupled to a non-radioactive ligand or vector molecule.

as low as reasonably achievable. This term is used to define the principle of underlying optimization of radiation protection for occupational workers and the public, including patients. This is practised based on the principles of time, distance and shielding, while placing an emphasis on creating adequate awareness among all stakeholders.

clinical trial. Any systematic study on (radio)pharmaceutical products in human subjects, whether in patients or other volunteers, in order to discover or verify the effects of, or identify any adverse reaction to, investigational products; and to study the absorption, distribution, metabolism and excretion of the products with the object of ascertaining their efficacy and safety.

Clinical trials are generally divided into phases I–IV, although phase IV studies usually do not apply to investigational radiopharmaceuticals, and thus are not mentioned further in this guideline. It is not always possible to draw clear distinctions between these phases, and different opinions about the details and methodology exist. However, the individual phases, based on their purposes as related to the clinical development of pharmaceutical products, can be briefly defined as follows:

- **Phase I.** These are the first trials for new radiopharmaceuticals (also called “first in human”), often carried out in healthy volunteers. Their purpose is to make a preliminary evaluation of safety, an initial pharmacokinetic and pharmacodynamic profile, and an initial safety assessment of the active ingredient and radiation dosimetry.
- **Phase II.** The purpose of studies in phase II is to determine activity and to assess short-term safety. The trials are performed in a limited number of subjects, but a greater number than in phase I, and aim to determine the optimal administered dose. In the case of therapeutic radiopharmaceuticals, they also aim to clarify the dose–response relationships in order to provide an optimal background for the design of extensive therapeutic trials.
- **Phase III.** This phase involves trials in large (and possibly varied) patient groups for the purpose of determining the short- and long-term safety and efficacy, and assessing the overall and relative diagnostic accuracy and therapeutic value of the intended radiopharmaceutical. Phase III studies are often multicentric. The pattern and profile of any frequent adverse reaction must be investigated and special features of the product must be explored (for example, clinically relevant drug interactions and factors leading to differences in effect, such as age). In general, the conditions under which the trials are conducted should be as close as possible to the normal conditions of use.

finished pharmaceutical product. With respect to radiopharmaceutical preparations, the finished pharmaceutical product is a combination of the active pharmaceutical ingredient and other components of the formulation such as diluents, radioprotectants and other formulation excipients. In some instances, the active pharmaceutical ingredient is co-produced concurrently with the

finished pharmaceutical product in a single seamless process. In other cases, the active pharmaceutical ingredient is synthesized first and then formulated further as a separate process to yield the finished pharmaceutical product. In all cases, the finished pharmaceutical product is created once the active pharmaceutical ingredient is formulated in the final formulation form.

good manufacturing practices for radiopharmaceutical products. Good manufacturing practices (GMP) for radiopharmaceutical products are a set of practices, using a traceable process, that ensure that radiopharmaceutical products are consistently produced and controlled to the quality standards appropriate for their intended use and designed to consistently yield the radiopharmaceutical product. GMP fall under the umbrella of the overall quality management system.

investigational radiopharmaceutical. Any radiopharmaceutical product (new compound or a commercial product) being evaluated in a clinical trial.

investigator. The person responsible for the trial and for protecting the rights, health and welfare of the subjects in the trial. The investigator must be an appropriately qualified person, legally allowed to practice medicine or dentistry.

manufacturing or production. For the purpose of this document, these terms are defined in the same way as in the *IAEA/WHO guideline on good manufacturing practices for radiopharmaceutical products* (3). They refer to all the operations performed leading up to the finished pharmaceutical product, including the purchase of starting materials, production, quality control, release and storage of radiopharmaceuticals.

monitor. A person appointed by the sponsor who is responsible for monitoring and reporting the progress of the trial and for the verification of data.

order. An instruction to process, package and ship a certain number of doses of an investigational radiopharmaceutical.

preparation or kit reconstitution. For the purpose of this document, these terms are defined in the same way as in the *IAEA/WHO guideline on good manufacturing practices for radiopharmaceutical products* (3). They refer to all the procedures carried out as per instructions from marketing authorization holders that involve addition of radionuclide solution approved by regulatory authorities to an approved cold kit.

product specification file. A reference file containing all the information necessary to draft the detailed written instructions on processing, packaging, labelling, quality control testing, batch release, storage conditions and shipping.

protocol. A document that gives the background, rationale and objectives of the trial and describes its design, methodology and organization, including statistical considerations and the conditions under which it is to be performed and managed. The protocol should be dated and signed by the investigator or institution involved and the sponsor, and can, in addition, function as a contract.

radiopharmaceutical product. For the purpose of this document, this term is defined in the same way as in the *IAEA/WHO guideline on good manufacturing practices for radiopharmaceutical products* (3), as any pharmaceutical product that, when ready for use, contains one or more radionuclides (radioactive isotopes) included for medicinal purposes.

retention sample. An additional sample of the final drug product that is collected and stored for the purpose of being analysed, should the need arise.

sponsor. An individual, company, institution or organization that takes responsibility for the initiation, management and financing of a clinical trial. When an investigator independently initiates and takes full responsibility for a trial, the investigator also then assumes the role of the sponsor.

4. Quality management

- 4.1 There should be a comprehensively designed, clearly defined, documented and correctly implemented quality management system in place. Senior management should assume the responsibility for this, as well as for the quality of the investigational product.
- 4.2 All parts of the quality management system should be adequately resourced and maintained.
- 4.3 The quality management system should incorporate GMP, which should be applied to all stages of the product life cycle, including the transfer of technology and the interface between the manufacture and the trial sites (for example, with regard to shipment, storage and labelling).
- 4.4 The quality management system should ensure that:
 - products are designed and developed in accordance with the requirements of this document and other associated guidelines, such as good clinical practices, good laboratory practices, good storage and distribution practices, and GMP for radiopharmaceuticals, as appropriate (3–6);
 - responsibilities are clearly specified in job descriptions;
 - operations are clearly specified in a written form;

- arrangements are made for the manufacture, supply and use of the correct starting and packaging materials;
- all necessary controls on starting materials, intermediate products, bulk products and other in-process controls are in place;
- calibrations and validations are carried out where necessary;
- the finished radiopharmaceutical product is correctly processed and quality controlled according to the defined procedures;
- there is an appropriate system for quality risk management;
- satisfactory arrangements exist to ensure, as far as possible, that the investigational radiopharmaceuticals are stored, distributed and subsequently handled so that their quality is maintained;
- deviations and changes are investigated and recorded with an appropriate level of root cause analysis done and appropriate corrective and preventive actions identified and taken.

4.5 For the manufacture of phase I and II radiopharmaceutical investigational products, the information on deviations, changes, out-of-specification investigations and corrective and preventative actions may be captured in a documentation system that is less regimented than the standard operating procedures and forms that are normally used during manufacture of commercial radiopharmaceutical products where the degree of variability and reliability of the process has been established and validated. This less regimented documentation system allows for manufacturer flexibility, which is essential for the manufacture of the novel agent, as this process is inherently subject to a higher degree of variability when compared to agents in later stages of pharmaceutical development. Regardless of the documentation system utilized, the relevant information must be adequately captured and be traceable.

5. Quality risk management

5.1 A quality risk management system should cover a systematic process for the assessment, control, communication and review of risks to the quality of the product and, ultimately, to the protection of the trial subjects and patients (7). Specific areas of quality risk assessment should include:

- sterility assurance;
- expiration time;
- method of sterilization;
- mass of the drug substance or ligand;

- physicochemical properties of the radionuclide or radiopharmaceutical;
- planned dosing schedule (single dose or multiple doses into the same study subject);
- route of administration;
- agent specific in vitro stability;
- the degree of clinical investigator supervision.

5.2 The quality risk management system should ensure that:

- the evaluation of the risk is based on scientific knowledge and experience with the process and product, and is ultimately linked to the protection of the patient;
- as the agent development continues, the basis of risk assessment is the transition from scientific knowledge and experience to process validation;
- procedures and records for quality risk management system are retained;
- the level of effort, formality and documentation of the quality risk management system process is commensurate with the level of risk.

5.3 The quality risk management system should be applied both proactively and retrospectively, when appropriate.

6. Personnel

- 6.1 There should be a sufficient number of appropriately qualified personnel available to carry out all the tasks for which the manufacturer of investigational products is responsible.
- 6.2 Individual responsibilities should be clearly defined, recorded as written descriptions and understood by all persons concerned.
- 6.3 A designated person, with experience in product development, clinical trial processes, and relevant guidelines on GMP and good clinical practices, should ensure that there are systems in place that meet the requirements of this guideline and other relevant GMP guidelines.
- 6.4 Personnel involved in the development, production and quality control of investigational products should be appropriately trained in relevant GMP and in the requirements specific to the manufacture of investigational radiopharmaceuticals.

- 6.5 The personnel should also be trained appropriately to prevent radiation contamination and other associated risks.
- 6.6 Production and quality control operations should be carried out under the control of clearly identified responsible persons who are separately designated and independent from one another.
- 6.7 In the manufacture of investigational radiopharmaceuticals, the same operator may be qualified as either a production operator or a quality control operator, or both, and the training for a specific function should be documented. Normally, the same operator should not perform both manufacture and quality control testing of the same batch of investigational radiopharmaceuticals. In circumstances where this may not be possible (for example, in academic radiopharmacies with limited personnel that are not engaged in the manufacture of investigational radiopharmaceuticals for phase I–II clinical evaluations on a routine daily basis, and where the produced investigational agent use is limited to the inside of the same institution), the same trained operator may perform both production and quality control testing, but it must be ensured that the batch release is performed by another independent authorized person.
- 6.8 In the manufacture of investigational radiopharmaceuticals, it may be possible for an authorized person responsible for batch release to also participate in either the batch production or quality control of a particular batch of an investigational radiopharmaceutical. However, if this authorized person does participate in either production or quality control testing of the particular batch, they cannot be responsible for the release of this batch of investigational radiopharmaceutical.

7. Documentation

- 7.1 Good documentation is an essential part of a quality management system. The documents should be appropriately designed, prepared, reviewed and distributed. They should also be appropriate for their intended use.
- 7.2 The documents (such as standard operating procedures, batch records and official reports) should be approved, signed and dated by the appropriate responsible person or persons. No authorized document should be changed without the prior authorization and approval of the responsible persons.
- 7.3 The documentation requirements applied during the manufacture of phases I–II investigational radiopharmaceuticals may be less vigorous than the documentation requirements applied during the manufacture of

phase III investigational radiopharmaceuticals, but they would still need to be adequate to allow for traceability of the manufacturing process.

7.1 Specifications

- 7.4 Specifications (for starting materials, primary packaging materials, and intermediate, bulk and finished products), batch formulae and production instructions should be as precisely detailed as possible and should take into account the latest state of the art.
- 7.5 In developing specifications, attention should be paid to the characteristics that may affect the efficacy and safety of products, namely:
- sterility and bacterial endotoxins
 - radioactive strength
 - radiochemical purity
 - specific activity, if applicable
 - batch size that is intended for the trial, where applicable
 - in-use stability
 - preliminary storage conditions
 - shelf-life of the product
 - appearance of the finished pharmaceutical product
 - radionuclidic purity, if applicable
 - chemical purity, if applicable.
- 7.6 As a result of the development of an investigational radiopharmaceutical, specifications may be changed by following a documented procedure. Changes should be authorized by a responsible person. Each new version should take into account the latest data and information, current technology, and regulatory and pharmacopoeial requirements. There should be traceability to the previous version or versions. The reasons for any change should be recorded. The impact of the change on any ongoing clinical trial, product quality, stability, bioavailability or bioequivalence (where applicable) should be considered.
- 7.7 For phase II or III studies, information necessary to prepare the intended investigational radiopharmaceutical should be summarized in a product specification file, which contains reference to the relevant documentation (for example, standard operating procedures, qualification or validation protocols, analytical methods, stability data, or storage and shipment conditions) required to perform processing, packaging, quality control

testing, batch release, labelling, storage conditions or shipping of the desired product.

- 7.8 The product specification file should indicate who has been designated or trained as the designated responsible person or persons for the release of batches.
- 7.9 The product specification files should be continuously updated, whilst, at the same time, ensuring the appropriate traceability to any previous versions.

7.2 Manufacturing formulae and processing instructions

- 7.10 Detailed manufacturing formulae, processing and packaging instructions and records should be available. Where this is not possible, other clear, written instructions and written records should be available for every manufacturing operation or supply.
- 7.11 These records should be used when preparing the final version of the documents to be used in routine manufacture.
- 7.12 Batch records should be retained for at least five years after the termination or discontinuance of the clinical trial or after the approval of the investigational radiopharmaceutical.
- 7.13 Where the data are intended for inclusion in an application for marketing authorization purposes, the records should be maintained until the end of the life cycle of the product.

7.3 Batch manufacturing records

- 7.14 Processing, packaging and testing records should be kept in sufficient detail for the sequence of operations to be accurately traced. They should contain any relevant remarks that increase the existing knowledge of the product, allow and reflect changes and improvements in the manufacturing operations, and justify the procedures used.

8. Premises

- 8.1 The premises where investigational radiopharmaceutical products are manufactured should be located, designed, constructed and maintained to suit the operations to be carried out. The design of the laboratories used for the handling of radioactive materials should always consider the need for radiation protection and compliance with “as low as reasonably achievable” standards, and should exhibit a high level of cleanliness and controls to minimize possible microbial contamination (8–10).

- 8.2 In cases where the same facility and equipment are used to prepare different radiopharmaceuticals, including investigational radiopharmaceuticals, the layout and design of premises should aim to minimize the risk of errors and mix-ups and permit effective cleaning and maintenance in order to avoid contamination, cross-contamination and, in general, any adverse effect on the quality of the products.
- 8.3 General technical requirements for the premises involved in the routine production of radiopharmaceuticals also apply in the case of investigational radiopharmaceuticals. For instance, drains should be avoided wherever possible and should not be present in cleanrooms. Where drains are required, these should be appropriately designed: sinks should be excluded from clean areas, and access points to technical areas (for example, rooms to access the rear of hot cells) should be configured in a way that minimizes entrance of maintenance and technical personnel to the production (clean) areas.
- 8.4 The heating, ventilation and air-conditioning system and pressure cascade for the different areas should be appropriately designed and maintained to minimize the risk of product contamination, and to protect personnel from the risk of radiation exposure. Pressure differentials should be monitored in areas of the facility where relative pressure differentials need to be maintained (such as cleanrooms where the quality of air is controlled) (11).
- 8.5 The facility must be equipped with appropriate radiation monitoring systems suitable for routine radioactive contamination monitoring for both areas and operators.
- 8.6 The appropriate controls should be in place to promote containment of radioactive gases and vapours. The premises must be equipped with an appropriate radioactive gas emission monitoring system.
- 8.7 Radioactive gases should be removed through separate air handling units fitted with the appropriate filters before being exhausted. These should be regularly checked for performance. The recirculation of potentially radiation-contaminated air should not be allowed.
- 8.8 A dedicated area and dedicated equipment should be used for the manufacture of any investigational radiopharmaceutical product involving human blood or plasma.
- 8.9 Quality control laboratories should be segregated from production areas.

- 8.10 The premises must be equipped with appropriately designed radioactive decontamination areas where operator decontamination may be carried out in compliance with approved protocols. At a minimum, these areas should be equipped with handwashing and eye washing stations.
- 8.11 The facility must be equipped with appropriately designed radioactive waste storage areas.

9. Equipment and utilities

- 9.1 Equipment and utilities should be selected, located, constructed and maintained to suit the operations to be carried out.
- 9.2 Equipment and utilities should be qualified for their intended use. This may include user requirement specifications, design qualification (if applicable), installation qualification, operational qualification and performance qualification. Equipment and devices, as appropriate, should be calibrated and maintained.
- 9.3 Equipment maintenance, qualification and calibration operations should be recorded and records should be maintained.
- 9.4 Computerized systems, such as those controlling equipment, should be verified to ensure they are reliable and fit for the intended purpose (12).
- 9.5 The dose calibrator (also known as the activity meter) should be qualified using suitable reference standards. If such a reference standard recognized by a national authority is not available, dose calibrator manufacturer recommendations or published literature may be used when deciding upon the appropriate dial setting.

10. Materials

10.1 Starting materials

- 10.1 The consistency of the production of investigational radiopharmaceutical products may be influenced by the quality of the starting materials. Their physical, chemical and, when appropriate, microbiological properties should therefore be defined, documented in their specifications, and controlled.
- 10.2 Specifications for precursors for radiolabelling should be as comprehensive as possible, given the current state of knowledge. They should include, for example, identity, purity or certification of origin (if applicable) and any

other parameter or characteristic required to make the material suitable for its intended use.

- 10.3 Detailed information on the quality of precursors for radiolabelling and excipients (as well as of packaging materials) should be available.
- 10.4 Starting materials should be accepted by performing in-house testing. During the manufacture of investigational radiopharmaceuticals for phase I–II clinical trials, the in-house testing may also be in the form of a review of the certificate of analysis supplied by the reliable material supplier, to confirm compliance with the specification set by the investigational agent manufacturer. For positron emission tomography (PET) radiopharmaceuticals, the acceptance of materials based on review of the certificate of analysis may also apply to the phase III stage, as long as the final product release testing adequately confirms that materials of correct quality were used. For the manufacture of cold kit products, generators and therapeutic radiopharmaceuticals in phase III stages, additional physical tests (such as material identity confirmation) may need to be performed by the radiopharmaceutical manufacturer as part of the material acceptance process, in addition to a review of the certificate of analysis.

10.2 Reference standards for analytical purposes

- 10.5 Reference standards from reputable sources (such as qualified vendors) should be used, if available.
- 10.6 If not available from any source, the reference substance or substances for the precursor for radiolabelling should be prepared, fully characterized and released as reference materials by the producer of the investigational pharmaceutical product.

11. Production

- 11.1 Investigational radiopharmaceuticals intended for use in clinical trials should be manufactured at a facility that is specified in the investigational agent regulatory application.
- 11.2 Where activities are outsourced to contract facilities, the contract must then clearly state, inter alia, the responsibilities of each party, compliance with GMP or this guideline, and that the product or products to be manufactured or controlled are intended for use in clinical trials. Close cooperation between the contracting parties is essential.

- 11.3 Access to restricted areas should be by authorized and trained personnel only.
- 11.4 Processes should be designed to minimize the risk of contamination, cross-contamination and mix-ups. The following measures may be adopted to minimize these risks:
- procedures for clearing the room of previous product materials;
 - processing and filling in segregated areas;
 - avoiding the manufacture of different products at the same time, either in the same dedicated space or by the same personnel;
 - performing manufacturing area decontamination and visual prechecks;
 - using manufacturing closed systems (such as automated systems), whenever possible;
 - using preassembled kit (cassettes), whenever possible.
- 11.5 The stability and shelf-life of the finished product should be defined following the execution of a suitable written protocol.
- 11.6 The expiration dates and times for radiopharmaceuticals should be based on the results of an adequate number of stability studies.

11.1 Manufacturing operations

- 11.7 As process knowledge of an investigational radiopharmaceutical is often not comparable with that of a radiopharmaceutical used for standard clinical care, process validation may not always be complete during the development phase of products; thus, critical quality attributes, process parameters and in-process controls should be identified, based on risk management principles and experience with analogous products, if available.
- 11.8 The necessary instructions for production should be defined and may be adapted based on the experience gained during radiopharmaceutical development itself.
- 11.9 For sterile investigational products, the controls to assure sterility of the final drug product should be no less than for licensed products (10). However, sterility verification studies (for example, bacteristasis or fungistasis) may not need to be conducted prior to pivotal phase III studies.

11.2 Packaging and labelling

11.10 At least the following information should be listed on the primary packaging container label (3):

- name of the product and batch number
- name of the manufacturer
- route of administration
- amount of activity at calibration date and time in appropriate units
- volume
- where relevant, the international symbol for radioactivity
- cautionary statements (for example, “For clinical investigational use only”);
- the study or trial number.

Note: Reporting information about activity (“strength”) on the primary label may not always be possible due to radiation protection reasons. In this case, the information may be reported on the secondary packaging label.

11.11 In the absence of regulatory authority requirements, the following minimum information may be listed on the secondary packaging container label, in addition to any information listed on the primary packaging:

- the finished pharmaceutical product formulation composition
- excipient information
- storage instructions
- address of the manufacturer, study sponsor, or investigator, as appropriate
- radioactive concentration at calibration date and time, if applicable
- end-of-synthesis date and time
- expiration date and time
- specific activity or mass.

11.12 The packaging must ensure that the investigational product remains in good condition during transport and storage. Any opening of or tampering with the outer packaging during transport should be readily discernible.

12. Quality control

- 12.1 Quality control should cover the sampling and testing of both the starting materials and the radiopharmaceutical final drug products, ensuring that materials are not released for use until their quality has been determined to conform to the predefined acceptance specifications.
- 12.2 As processes may not be standardized or fully validated, testing takes on more importance in ensuring that each batch meets the approved specification at the time of testing.
- 12.3 The release of a batch of an investigational radiopharmaceutical product should only occur after the designated responsible person has certified that the product meets the relevant batch release requirements. At a minimum, these requirements should include the following:
 - a review and approval of batch records, including control reports, in-process test reports, changes, deviations and release reports demonstrating compliance with the product specification file, the order and protocol;
 - verification of appropriate production conditions;
 - verification of the quality of starting materials (for example, status of approval, certificate of analysis);
 - verification of the validation status of facilities, equipment, processes and methods, as appropriate;
 - verification of conditions of storage and shipment, if applicable;
 - verification of successful completion of quality control tests required for batch release.
- 12.4 Due to the inherent rapid radioactive decay of radiopharmaceuticals containing radionuclides with relatively short half-lives, these products may be released and administered prior to completion of all quality control testing. Under these circumstances, the required pre-release and post-release testing should be clearly defined and documented.
- 12.5 Sampling procedures should consider the nature and the characteristics of the material being sampled (for example, a small batch size or its radioactive content) to make sure that the samples are representative of the entire batch of radiopharmaceuticals.
- 12.6 Quality control samples should be prepared, handled and stored in a way that ensures the adequate identification and segregation of the test samples to avoid mix-ups and cross-contamination.

- 12.7 In the event that a finished radiopharmaceutical product batch fails to meet a release acceptance specification (that is, an out-of-specification event occurs), an investigation should be conducted and documented. During the investigation, the affected batch should be segregated and quarantined to prevent release. If the investigation confirms the out-of-specification result, the finished radiopharmaceutical product should be rejected. A confirmed out-of-specification event that is detected during post-release testing requires an immediate notification to the end clinician who has the drug product in their possession. A batch of finished radiopharmaceutical product involved in an out-of-specification event may be released only if (a) the investigation reveals clear evidence that the obtained result is invalid; and (b) confirmatory testing results confirm the absence of non-compliance with the acceptance specifications. Final disposition confirming or invalidating the out-of-specification event should be notified to the clinician as quickly as possible.
- 12.8 Retention samples from every batch of a particular investigational radiopharmaceutical product should only be collected if they can be used to obtain meaningful testing data in the future. However, the collection of the retention samples is not required. The duration of storage of retention samples should be based on the ability to collect valid test data from using the sample.

13. Qualification and validation

- 13.1 The extent of qualification and validation activities should be in accordance with a risk-based approach, considering the complexity and critical aspects of the intended radiopharmaceutical production.
- 13.2 The extent of qualification and validation required for the manufacture of investigational radiopharmaceuticals in phase I–II trials may be less than for the manufacture of investigational radiopharmaceuticals in pivotal phase III trials. Nevertheless, the critical characteristics of the investigational radiopharmaceutical should always be addressed. For example, critical manufacturing step in-process control parameters, such as reaction temperatures or transfer of the activities, may need to be defined and monitored at any stage of development; on the other hand, the validation of less critical controls, such as bioburden sample collection or determination of maximum in-process holding times, may not be required during phases I–II.
- 13.3 The facilities and equipment need to be properly maintained and calibrated at any stage of development.

- 13.4 Equipment should be qualified for its intended use. At a minimum, the equipment should be verified to be in conformance with the preventive maintenance and operational qualification requirements of the equipment manufacturer, as well as the performance qualification requirements of the investigational radiopharmaceutical manufacturer, as applicable.
- 13.5 The validation of aseptic investigational radiopharmaceutical production procedures presents special problems, as the batch size is often very small and the number of units filled may be not adequate for a full validation protocol. Thus, the validation of aseptic procedures needs to be supported by an operator and process validation via a media fill test, which consists of conducting a process simulation using broad spectrum bacterial growth media to demonstrate that the aseptic processing, controls and production environment are capable of producing a sterile product. The successful completion of media fill testing is a prerequisite for the clinical production of investigational radiopharmaceuticals at any stage of development.
- 13.6 Manufacturing process validation should only be carried out after all of the critical requirements (for example, media fill testing, relevant standard operating procedures for operator training, and preventive maintenance and operational qualification of equipment) have been completed. The validation batches campaign should include an adequate number of batches of the intended radiopharmaceutical(s). The number of batches and the batch size range should be predetermined as part of a risk assessment performed prior to process validation. In general, the completion of a minimum of three consecutive batches aimed for validation and stability studies is sufficient for the purposes of completing manufacturing process validation in phase I trials. However, the number of batches produced may need to be increased in certain situations. For example, more validation and stability runs may be required when the manufacturer is trying to qualify multiple suppliers of a particular critical component (such as radionuclide provided by multiple suppliers).
- 13.7 Defined, documented and reproducible analytical methods aimed to establish chemical, radiochemical and radionuclidic purity, as well as identity, specific activity (if applicable) and impurities content, should be established before any manufacture for human subjects begins. However, analytical method validation protocols fully compliant with the International Council for Harmonisation of Technical Requirements for Pharmaceuticals for Human Use (ICH) standards (13) for validation may be generated and implemented as part of the transition into pivotal phase III trials.

- 13.8 Compendial analytical methods applied by the investigational radiopharmaceutical manufacturer that are described in relevant pharmacopeia do not require validation but may require verification prior to the initiation of manufacture for pivotal phase III trials. For example, the compendial endotoxin testing method may not require full analytical method validation as described in relevant ICH guidances but may require the verification via conduct of specific inhibition and enhancement studies of the finished pharmaceutical product.
- 13.9 General principles on validation of analytical procedures may be followed (13); however, the unique nature of radioactivity should be considered and specific adaptations should be made, where required.

14. Complaints

- 14.1 There should be a written procedure describing the management of complaints. The procedure should provide a clear and concise description of responsibilities, actions that may need to be undertaken, communication pathways and structure, traceability and reporting requirements in the event that a complaint is received.
- 14.2 Any complaint concerning a product defect should be recorded with all the original details and thoroughly investigated.
- 14.3 Where necessary, the appropriate follow-up action, possibly including product recall, should be taken after the investigation and evaluation of the complaint.
- 14.4 All decisions made and measures taken as a result of a complaint should be recorded and referenced to the corresponding batch records.
- 14.5 Any potential impact on the trial or on the product development should be investigated in order to determine the cause and take any necessary corrective action.

15. Recalls

- 15.1 There should be a written procedure describing the management of a recall of an investigational radiopharmaceutical. The procedure should provide a clear and concise description of responsibilities, actions that may need to be undertaken, communication pathways and structure, traceability and reporting requirements in the event a product recall is initiated.

- 15.2 The recall of a product should be documented and inventory records should be kept.
- 15.3 Multiple project-specific and product recall procedures may need to be implemented for various radiopharmaceuticals in order to reflect the requirements for a specific project. For example, the product recall requirements for a manufacturer that supplies investigational agents to the clinic within the same institution or hospital may differ significantly from the manufacturer that works with a pharmaceutical company sponsor and distributes the manufactured product to multiple external clinics. In all cases, the exact requirements need to be clearly defined and the staff need to be trained on those specific requirements.

16. Returns

- 16.1 Investigational radiopharmaceuticals should be returned under the agreed conditions defined by the sponsor, specified in written procedures and approved by authorized staff members.
- 16.2 Return processes should be in accordance with the handling of radioactivity and radiation protection rules.
- 16.3 Inventory records of returned products should be kept.
- 16.4 Returned radiopharmaceuticals should not be reused.
- 16.5 Since the return of radioactive products is often not practical, the main purpose of recall procedures for radiopharmaceutical products should be to prevent their use, rather than an actual return. If necessary, the return of radioactive products should be carried out in accordance with national and, where applicable, international transport regulations (14).

17. Shipping

- 17.1 The shipping of investigational radiopharmaceuticals should be carried out in accordance with written procedures laid down in the protocol or shipping order given by the sponsor.
- 17.2 Shipping processes should also be in accordance with international and local rules (14).
- 17.3 The shipment should be accompanied by a printed form, including the relevant information related to the investigational radiopharmaceutical (for example, the same information included in the secondary packaging label).

18. Destruction

- 18.1 The activity of the active principle of investigational radiopharmaceuticals decreases following the decay law and half-life of the radionuclide; thus, usually there is no need for product destruction.
- 18.2 Should the product be destroyed, however, international and local rules on handling radioactivity and radiation protection should be followed. A dated certificate of, or receipt for, destruction should be provided to the sponsor. These documents should clearly identify or allow traceability of the batches and patient numbers involved and the actual quantities destroyed.

References

1. Good manufacturing practices: supplementary guidelines for the manufacture of investigational pharmaceutical products for clinical trials in humans. In: WHO Expert Committee on Specifications for Pharmaceutical Preparations: thirty-fourth report. WHO Technical Report Series No. 863, Annex 7. Geneva: World Health Organization; 1996 (<https://apps.who.int/iris/handle/10665/41849>, accessed 16 August 2022).
2. WHO good manufacturing practices for investigational products. In: WHO Expert Committee on Specifications for Pharmaceutical Preparations: fifty-sixth report. WHO Technical Report Series No. 1044, Annex 7. Geneva: World Health Organization; 2022.
3. International Atomic Energy Agency and World Health Organization guideline on good manufacturing practices for radiopharmaceutical products. In: WHO Expert Committee on Specifications for Pharmaceutical Preparations: fifty-fourth report. WHO Technical Report Series No. 1025, Annex 2. Geneva: World Health Organization; 2020 (<https://apps.who.int/iris/handle/10665/331814>, accessed 16 August 2022).
4. Handbook for good clinical research practice (GCP): guidance for implementation. Geneva: World Health Organization; 2005 (<https://apps.who.int/iris/handle/10665/43392>, accessed 30 August 2022).
5. Handbook: Good laboratory practice: quality practices for regulated non-clinical research and development. Geneva: World Health Organization; 2001 (<https://apps.who.int/iris/handle/10665/66894>, accessed 12 September 2022).
6. Good storage and distribution practices for medical products. In: WHO Expert Committee on Specifications for Pharmaceutical Preparations: fifty-fourth report. WHO Technical Report Series No. 1025, Annex 7. Geneva: World Health Organization; 2020 (<https://apps.who.int/iris/handle/10665/331814>, accessed 16 August 2022).
7. WHO guidelines on quality risk management. In: WHO Expert Committee on Specifications for Pharmaceutical Preparations: forty-seventh report. WHO Technical Report Series No. 981, Annex 2. Geneva: World Health Organization; 2013 (<https://apps.who.int/iris/handle/10665/81144>, accessed 16 August 2022).
8. Radiation protection and safety of radiation sources: international basic safety standards. General Safety Requirements, Part 3. Vienna: International Atomic Energy Agency; 2014 (https://www-pub.iaea.org/MTCD/publications/PDF/Pub1578_web-57265295.pdf, accessed 16 August 2022).

9. Radiation protection and safety in medical uses of ionizing radiation. IAEA Safety Standards Series No. SSG-46. Vienna: International Atomic Energy Agency; 2018 (<https://www.iaea.org/publications/11102/radiation-protection-and-safety-in-medical-uses-of-ionizing-radiation>, accessed 16 August 2022).
10. WHO good manufacturing practices for sterile pharmaceutical products. In: WHO Expert Committee on Specifications for Pharmaceutical Preparations: forty-fifth report. WHO Technical Report Series No. 961, Annex 6. Geneva: World Health Organization; 2011 (<https://apps.who.int/iris/handle/10665/44079>, accessed 16 August 2022).
11. ISO 14644:2019. Cleanrooms and associated controlled environments – Part 3: Test methods. International Organization for Standardization; 2019.
12. WHO good manufacturing practices: guidelines on validation. Appendix 5: Validation of computerized systems. In: WHO Expert Committee on Specifications for Pharmaceutical Preparations: fifty-third report. WHO Technical Report Series No. 1019, Annex 3. Geneva: World Health Organization; 2019 (<https://apps.who.int/iris/handle/10665/312316>, accessed 13 September 2022).
13. Validation of analytical procedures: text and methodology. Topic Q2 (R1). Geneva: International Council for Harmonisation of Technical Requirements for Pharmaceuticals for Human Use (ICH); 2005 (<https://database.ich.org/sites/default/files/Q2%28R1%29%20Guideline.pdf>, accessed 17 August 2022).
14. IAEA safety standards for protecting people and the environment. Regulations for the safe transport of radioactive material, 2018 edition. Specific Safety Requirements No. SSR-6 (Rev. 1). Vienna: International Atomic Energy Agency; 2018 (https://www-pub.iaea.org/MTCD/Publications/PDF/PUB1798_web.pdf, accessed 17 August 2022).

Further reading

- International Ethical Guidelines for Health-related Research Involving Humans Prepared by the Council for International Organizations of Medical Sciences (CIOMS) in collaboration with the World Health Organization (WHO), Geneva, 2016. Geneva: CIOMS; 2016 (<https://cioms.ch/wp-content/uploads/2017/01/WEB-CIOMS-EthicalGuidelines.pdf>, accessed 17 August 2022).
- The International Pharmacopoeia. Geneva: World Health Organization; updated regularly (<https://www.who.int/teams/health-product-and-policy-standards/standards-and-specifications/norms-and-standards-for-pharmaceuticals/pharmacopoeia>, accessed 12 September 2022).
- EudraLex – Volume 4 – Good Manufacturing Practice (GMP) guidelines. EU Commission Directives 91/356/EEC, as amended by Directive 2003/94/EC and 91/412/EEC (https://health.ec.europa.eu/medicinal-products/eudralex/eudralex-volume-4_en, accessed 17 August 2022).
- WHO good manufacturing practices for pharmaceutical products: main principles. In: WHO Expert Committee on Specifications for Pharmaceutical Preparations: forty-eight report. WHO Technical Report Series No. 986, Annex 2. Geneva: World Health Organization; 2014 (<https://apps.who.int/iris/handle/10665/112733>, accessed 17 August 2022).

Annex 4

WHO guidelines on technology transfer in pharmaceutical manufacturing

Background

During the fifty-fifth meeting of the World Health Organization Expert Committee on Specifications for Pharmaceutical Preparations, Expert Committee members were updated on the annual consultation on good practices for health products manufacture and inspection, which took place in July 2020 over a series of virtual meetings due to the COVID-19 pandemic. During these virtual meetings, a group of experts made a series of proposals for future activities, including a possible update of the *WHO guidelines on transfer of technology in pharmaceutical manufacturing (1)*. This original document was published in 2011, since when numerous regulatory changes have been made. Transfer of technology is considered an integral part of the product life cycle management and is subject to regulatory expectations, including in the areas of a risk-based and science-based process and method design (such as a quality by design approach), achieving a state of control, and data governance. The original document therefore requires updating, not least to support the consistent supply of therapies for critical needs, including public health emergencies.

The Expert Committee asked the WHO Secretariat to explore this proposal.

Contents

Background	197
Abbreviations	199
1. Introduction	199
2. Scope	200
3. Glossary	202
4. Due diligence and gap analysis	206
5. Organization and management	207
6. Quality management and quality risk management	209
7. Documentation	210



8. Premises	211
9. Equipment and instruments	211
10. Qualification and validation	212
11. Life cycle approach	213
12. Phases of a technology transfer project	213
Phase I: Project initiation	213
Phase II: Project planning	214
Phase III: Project transfer execution	216
Production (example: finished pharmaceutical product)	216
Quality control: analytical procedure transfer	217
Cleaning	219
Phase IV: Project review and close-out	220
References	220
Appendix 1 Documentation commonly required for technology transfer	223

Abbreviations

ALCOA	attributable, legible, contemporaneous, original and accurate
API	active pharmaceutical ingredient
ICH	International Council for Harmonisation of Technical Requirements for Pharmaceuticals for Human Use
RU	receiving unit
SU	sending unit

1. Introduction

- 1.1 Technology transfer is a logical procedure involving the transfer of products, processes and knowledge, supported by relevant documentation and professional expertise. Technology transfer may include development, manufacturing and testing sites.
- 1.2 The transfer of production and control procedures of pharmaceutical products from one site to another may take place before or after obtaining regulatory marketing authorization. Product transfer may therefore occur during development, full-scale commercialization and commercial batch manufacturing. The level of rigour applied in the technology transfer should be commensurate with the respective product life cycle phase.
- 1.3 Technology transfer, particularly between different companies, has legal and economic implications that may include intellectual property rights, royalties, pricing, conflict of interest and confidentiality agreements. Such matters should therefore be addressed in undertaking the transfer.
- 1.4 Technology transfer requires a planned approach by trained, knowledgeable personnel working within a quality system with the appropriate documentation, data and information covering all aspects of development, production and quality control, as applicable, and considering the stage of the product life cycle and the regulatory requirements.
- 1.5 Technology transfer takes place between a sending unit (SU) and a receiving unit (RU). In some cases, it may be advantageous to establish a separate unit to manage the project.
- 1.6 The technology transfer project should fulfil the following general principles and requirements. There should be:
 - a documented project plan covering the relevant aspects of the project;

- a detailed quality risk management plan;
 - a comprehensive gap analysis, including due diligence performed covering technical, quality and regulatory aspects;
 - similar capabilities between the SU and RU, including facilities and equipment, where appropriate;
 - knowledge of the differences in process ability between the SU and RU, including the impact, risk and control strategies to overcome any differences;
 - a sufficient number of adequately trained personnel with suitable qualifications and experience;
 - effective process and product knowledge management;
 - effective communication and transparency between the SU and RU.
- 1.7 Technology transfer should include relevant documentation, data, information and knowledge from the SU in order to enable the RU to effectively execute the specified process or procedure in, for example, production and quality control. A successful technology transfer project should result in documented evidence that the RU can routinely reproduce the transferred product, process or procedure against a predefined set of specifications, as agreed between the SU and RU.
- 1.8 This document should be read in conjunction with other WHO guidelines, as referenced below (2–15), as well as other regulatory guidelines, including the International Council for Harmonisation of Technical Requirements for Pharmaceuticals for Human Use (ICH) guidelines Q7, Q8, Q9, Q10, Q11 and Q12. This guideline does not intend to replace any of those guidelines.
- 1.9 Product, process and procedure knowledge should be an essential part of the transfer process from the SU to the RU.
- 1.10 The critical quality attributes, critical process parameters, material attributes, control strategy and any other elements potentially impacting the quality of the product should be available (see also ICH guidelines).
- 1.11 This version of the document provides guiding principles reflecting current good practices in technology transfer and replaces the previous version published by the World Health Organization (WHO) (1).

2. Scope

- 2.1 This document provides guiding principles on technology transfer, including transfer from research and development to production sites,

and between two production sites. The principles therefore apply to newly commercialized products as well as to marketed products. The principles may also be applied to investigational products.

- 2.2 Throughout life cycle stages, transfers should be appropriate and proportionate to the phase of the product life cycle in order to ensure that product knowledge is maintained and that processes are appropriately controlled. This guideline should be applied when transferring the technology of manufacturing processes and analytical procedures relating to active pharmaceutical ingredients (APIs), isolated API intermediates, bulk drug products and finished pharmaceutical products. While medical devices as part of the finished pharmaceutical product of a combination medicinal product would be considered under this guidance, the specific regulatory and quality requirements for medical device manufacturing are covered under separate medical device regulations and quality management systems.
- 2.3 The guideline applies to all pharmaceutical dosage forms and may be adapted on a case-by-case basis by using risk management principles. Particular attention should be given to certain complex formulations, such as sterile products and metered dose inhalers.
- 2.4 Although this document focuses on pharmaceutical products, the principles can also be applied to the transfer of production, related processes and controls for other products, such as vaccines, biotherapeutic products, advanced therapy medicinal products, cell and gene therapy products, medical devices and vector control products.
- 2.5 Because each transfer project is unique, the provision of a comprehensive set of guidelines specific to a product or process is beyond the scope of this document.
- 2.6 This document does not provide guidance on any intellectual property, legal, financial or commercial considerations associated with technology transfer projects. These are prerequisites for a successful transfer that need to be defined and controlled prior to the transfer in the course of due diligence. Examples include health, safety and environmental aspects and the availability of confidentiality disclosure agreements, which should be in place prior to the start of the transfer.
- 2.7 This document addresses the following principal areas:
 - organization and management of the transfer;
 - transfer of relevant information in production, including processing, packaging and analytical procedures;

- documentation, premises and equipment;
- personnel qualification and training;
- quality management and risk management;
- change management and life cycle approach;
- control strategy;
- qualification and validation.

3. Glossary

The definitions given below apply to the terms used in these guidelines. They have been aligned as much as possible with the terminology in related WHO guidelines and good practices and included in the WHO *Quality Assurance of Medicines Terminology Database: list of terms and related guideline*,¹ but may have different meanings in other contexts.

acceptance criteria. Measurable terms under which a test result will be considered acceptable.

active pharmaceutical ingredient (API). Any substance or mixture of substances intended to be used in the manufacture of a pharmaceutical dosage form and that, when so used, becomes an active ingredient of that pharmaceutical dosage form. Such substances are intended to furnish pharmacological activity or other direct effect in the diagnosis, cure, mitigation, treatment or prevention of disease, or to affect the structure and function of the body.

ALCOA+. A commonly used acronym for “attributable, legible, contemporaneous, original and accurate” that puts additional emphasis on the attributes of being complete, consistent, enduring and available – implicit basic ALCOA principles.

bracketing. An experimental design to test the extremes of, for example, dosage strength. The design assumes that the extremes will be representative of all the samples between the extremes.

change control. A formal system by which qualified representatives of appropriate disciplines review proposed or actual changes that might affect the registration and validated status. The intent is to determine the need for action that would ensure that the system is maintained in a regulatory compliant and validated state.

¹ https://www.who.int/docs/default-source/medicines/norms-and-standards/guidelines/mqa-terminology-sept-2020.pdf?sfvrsn=48461cfc_5.

confirmation testing. An execution of tests that confirm and validate the results obtained by another test.

control strategy. A planned set of controls, derived from current product and process understanding, that assures process performance and product quality. The controls can include parameters and attributes related to API and finished pharmaceutical product materials and components, facility and equipment operating conditions, in-process controls, finished product specifications, and the associated methods and frequency of monitoring and control.

corrective action. Any action to be taken when the results of monitoring at a critical control point indicate a loss of control.

critical. Having the potential to impact product quality or performance in a significant way.

critical process parameter. A process parameter whose variability has an impact on a critical quality attribute and therefore should be monitored and controlled to ensure the process produces the desired quality.

critical quality attribute. A physical, chemical, biological or microbiological property or characteristic that should be within an appropriate limit, range or distribution to ensure the desired product quality.

design space. The multidimensional combination and interaction of input variables (such as material attributes) and process parameters that have been demonstrated to provide assurance of quality.

drug master file. Detailed information concerning a specific facility, process, packaging material or product submitted to the medicines regulatory authority, intended for incorporation into the application for marketing authorization.

finished pharmaceutical product. A product that has undergone all stages of production, including packaging in its final container and labelling. A finished pharmaceutical product may contain one or more APIs. In some cases, it may be in combination with a medical device.

gap analysis. The identification of the critical elements of a process that are available at the sending unit (SU) but are missing from the receiving unit (RU) with the objective of assessing which gaps have a potential impact on the process or method and to mitigate those gaps, as appropriate.

good manufacturing practices. That part of quality assurance that ensures that pharmaceutical products are consistently produced and controlled to the quality standards appropriate to their intended use and as required by the marketing authorization.

good practices. A collection of quality guidelines and regulations in order to ensure that products are safe, effective, and of required quality; meet their intended use; and adhere to quality processes during production, control, storage and distribution.

in-process control. Checks performed during production in order to monitor and, if necessary, adjust the process to ensure that the product conforms to its specifications. The control of the environment or equipment may also be regarded as a part of in-process control.

installation qualification. Documented verification that the installations (such as machines, equipment and instruments, computer system components, measuring devices, utilities and manufacturing) used in a processor system are appropriately selected and correctly installed, in accordance with established specifications.

intercompany transfer. A transfer of technology between the sites of different companies.

intracompany transfer. A transfer of technology between sites of the same group of companies.

marketing authorization holder. An individual or a corporate entity being in possession of a marketing authorization of a pharmaceutical product.

operational qualification. Documented verification that the system or subsystem performs as intended over all anticipated operating ranges.

process validation. The collection and evaluation of data, from the process design stage through to commercial production, that establish scientific evidence that a process is capable of consistently delivering the API or finished pharmaceutical product meeting its predetermined specifications and quality attributes.

qualification. Documented evidence that premises, systems or equipment are able to achieve the predetermined specifications when properly installed and working correctly, and lead to the expected results.

quality assurance. Quality assurance is a wide-ranging concept covering all matters that individually or collectively influence the quality of a product. It is the totality of the arrangements made with the objective of ensuring that pharmaceutical products are of the quality required for their intended use.

quality control. All measures taken, including the setting of specifications, sampling, testing and analytical clearance, to ensure that starting materials,

intermediates, packaging materials and finished pharmaceutical products conform with established specifications for identity, strength, purity and other characteristics.

quality planning. Part of quality management, quality planning entails setting quality objectives and specifying necessary operational processes and related resources to fulfil the quality objectives.

quality policy. A brief statement that describes the organization's purpose, overall intentions and strategic direction; provides a framework for quality objectives; and includes a commitment to meet applicable requirements.

quality risk management. A systematic process for the assessment, control, communication and review of risks to the quality of the pharmaceutical product throughout the product's life cycle.

receiving unit (RU). The involved disciplines at an organization where a designated product, process or method is expected to be transferred.

sending unit (SU). The involved disciplines at an organization from where a designated product, process or method is expected to be transferred.

standard operating procedure. An authorized written procedure giving instructions for performing operations, not necessarily specific to a given product or material, but of a more general nature (for example, operation of equipment, maintenance and cleaning, validation, cleaning of premises, and environmental control, sampling and inspection). Certain standard operating procedures may be used to supplement product-specific master and batch production documentation.

starting material. Any substance of a defined quality used in the production of a pharmaceutical product, but excluding packaging materials.

technology transfer, transfer of technology. A logical procedure that controls the transfer of any product or process, including product or process knowledge, together with its documentation and professional expertise. Technology transfer may involve development, manufacturing or testing sites.

technology transfer protocol (master plan). A document that describes the intended sequential phases and activities of the transfer, and serves as a plan for the execution and management of the transfer.

technology transfer report. A documented summary of a specific technology transfer project listing procedures, acceptance criteria, results achieved and conclusions.

validation. Action of proving and documenting that any process, procedure or method actually and consistently leads to the expected results.

validation batches. Those batches produced by the receiving unit (RU) to demonstrate its ability to manufacture the transferred product in compliance with its predetermined specifications, or as part of process performance qualification.

validation master plan. A high-level document that summarizes the manufacturer's overall philosophy and approach, to be used for establishing performance adequacy. It provides information on the manufacturer's qualification and validation work programme and defines details of and timelines for the work to be performed, including a statement of the responsibilities of those implementing the plan.

validation protocol. A document describing the activities to be performed during validation, including the acceptance criteria.

validation report. A document in which the records, results and evaluation of validation are documented and summarized. It should also contain a conclusion of the outcome of the validation.

4. Due diligence and gap analysis

- 4.1 When considering a technology transfer project, the first steps should include a process of due diligence and gap analysis through visits to the SU and RU.
- 4.2 The suitability and degree of preparedness of the RU should be assessed prior to the start of the transfer. The procedure to be followed and the results and conclusions should thereafter be documented.
- 4.3 The gap analysis should be performed by a team of appropriately qualified persons with knowledge and experience in the field of good practices and the activity to be transferred. It is recommended that the quality units of the SU and RU participate in this activity. The team should be involved throughout each phase of the project, as appropriate (see section 12 on phases of a technology transfer project).
- 4.4 The gap analysis should further cover the capabilities and resources related to personnel, premises, equipment and instruments, utilities, cleaning, quality control, documentation, computerized systems, qualification, validation, and further health, safety and environment-related considerations, including waste management.

- 4.5 The gap analysis to determine the feasibility for technology transfer may include technical, engineering, business, quality, regulatory, supply and legal aspects.

5. Organization and management

- 5.1 All technology transfer activities should be organized and planned.
- 5.2 There should be formal written agreements, signed between the parties involved in technology transfer, that specify the responsibilities of each party before, during and after transfer. The agreements should cover, for example, data management, data integrity, documentation and validation.
- 5.3 All the necessary activities to be executed during the technology transfer project should be identified, organized and documented at the start of the project. The responsibilities of the SU, RU, sponsor and marketing authorization holder should be defined in writing.
- 5.4 Where applicable, the marketing authorization holder should coordinate the transfer of the necessary documentation related to the technology transfer from the SU to the RU, including the relevant regulatory documents. The product dossier, production and control documentation should be assessed for compliance with regulatory requirements before the transfer of the documentation.
- 5.5 The SU should provide criteria and information on the inherent risks, hazards and critical steps associated with the process, product or procedure to be transferred. These may serve as a basis for the gap analysis and risk assessment exercises.
- 5.6 The technology transfer should be managed by responsible persons from each site (the SU and RU) and any other units with the appropriate technical and quality oversight. A technology transfer team may be appointed with identified and documented responsibilities.
- 5.7 The team members should have the necessary qualifications and experience to manage the particular aspects of the transfer.
- 5.8 The SU should make available in relevant documents all the necessary information and knowledge with regard to the product, process or procedure in order to ensure a successful transfer.
- 5.9 The RU should be able to accommodate the intended production capacity. If possible, it should be established at the outset whether or not the intention is to perform single-batch manufacture, continuous production or campaigns.

- 5.10 Consideration should be given to the level and depth of detail to be transferred to support production and any further process development and optimization at the RU, as intended under the transfer project plan.
- 5.11 Consideration should be given to the technical expertise, site technology and site capabilities of the RU. Any product and process robustness issues should be identified at the outset by the SU so that plans may be put in place at the RU.
- 5.12 The SU should assess the suitability and degree of preparedness of the RU before transfer with regard to personnel, premises, equipment, materials, suppliers and support services (specifically, purchasing and inventory control mechanisms and the pharmaceutical quality system – quality control procedures, documentation, computer validation, site validation, equipment qualification, water for pharmaceutical production and waste management).
- 5.13 The SU and the RU should jointly verify that the following, satisfactorily completed, qualification and validation protocols and reports are available:
- installation qualification and operational qualification data for manufacturing and packaging equipment at the RU site and analytical equipment;
 - qualification of the rooms for both manufacture and packaging at the RU site;
 - cleaning validation.
- 5.14 A training programme should be implemented covering various topics, including those specific to the process, product or procedure to be transferred. The effectiveness of training should be evaluated. Records should be maintained.
- 5.15 Changes and adaptations made during the course of the project should be done in accordance with a standard procedure. Risk assessment, where appropriate, should cover technical, quality, regulatory and other aspects. The project manager should evaluate the impact to the project cost, schedule, and resourcing based on an updated risk assessment.
- 5.16 The execution of the technology transfer project should be documented, for example in a report, supported by the relevant data. The overall technology transfer strategy and acceptance criteria to confirm a successful transfer should be documented a priori in the technology transfer protocol. These should consider the stage of development – both clinical and

commercial stages (including the fulfilment of relevant regulatory country requirements).

- 5.17 Whenever possible, targeted on-site or virtual visits between the SU and RU at critical phases of the project should be allowed to assist with the transfer of knowledge.
- 5.18 Data should be in accordance with ALCOA+ principles.

6. Quality management and quality risk management

- 6.1 The SU and RU should each have an appropriately designed, clearly defined and documented quality management system.
- 6.2 The quality management system should be adequately resourced, implemented and maintained.
- 6.3 The quality management system should incorporate good practices that should be applied to the life cycle stages of the products and processes, including technology transfers.
- 6.4 The quality management system should ensure that:
- responsibilities are clearly specified in writing
 - operations are clearly defined in writing
 - there is a system for change management
 - there is a system for quality risk management
 - arrangements are made for the documented technology transfer.
- 6.5 Quality risk management should be implemented as a systematic process for the assessment, control, communication and review of risks.
- 6.6 The system for quality risk management should be described in writing and cover appropriate areas, including premises, equipment, materials, products, production, processes, quality control and microbiology, qualification, validation and the process of technology transfer.
- 6.7 The evaluation of the risk should be based on scientific knowledge and experience, including that of the process and product.
- 6.8 The level of effort, formality and documentation of the quality risk management process should be commensurate with the level of risk.
- 6.9 The procedures and records for quality risk management should be retained.

7. Documentation

7.1 An authorized technology transfer document – for example, a master plan or technology transfer protocol – should list the intended sequential phases and activities of the transfer, where appropriate. The document should include the following:

- title;
- objective;
- scope;
- names and addresses of the SU and RU;
- technology transfer team, including key personnel and their responsibilities, from SU and RU;
- phases of the project, including key activities, deliverables and associated accountabilities;
- approximate timing of key activities and deliverables, including the timing of trial production batches and validation batches;
- reference to other transfer plan documents relevant to the process being transferred;
- reference to validation master plans relevant to the process being transferred, including equipment, facilities and utilities qualification project plan, site-independent or site-dependent process validation master plan, method validation master plan;
- reference to gap analysis and risk assessments;
- acceptance criteria for a successful transfer;
- a parallel comparison of premises, equipment, instruments, materials, procedures, and methods for the transfer under consideration.

Note: A list with examples of documents commonly required in technology transfer is presented in Appendix 1.

7.2 Standard operating procedures should be followed, describing the actions to be taken during the technology transfer process.

7.3 Records should be maintained of the activities performed during the technology transfer process (such as a technology transfer report). The report content should reflect the protocol and standard operating procedures that were followed. The report should summarize the scope of the transfer, the critical parameters as obtained in the SU and RU, and the final conclusions of the transfer. Changes, deviations, investigations and the relevant appropriate actions taken should be recorded. The SU should

provide all the relevant supportive documents with data, results and other relevant information in order to facilitate a successful technology transfer.

8. Premises

- 8.1 The RU should have appropriate premises with a layout, construction and finishing suitable for the intended operations. Utilities such as heating, ventilation and air-conditioning, as well as gas and water systems, should have sufficient capacity and should be appropriate for the intended process, product or procedure to be transferred.
- 8.2 The SU should provide the RU with information on relevant health, safety and environmental issues, including:
 - the inherent risks of the manufacturing processes (for example, reactive chemical hazards, exposure limits, fire and explosion risks, microbiological contamination risks);
 - health and safety requirements to minimize operator exposure to and ensure containment and management of pharmaceutical waste;
 - emergency planning considerations (for example, in case of gas or dust release, spillage, fire or firewater run-off);
 - identification of waste streams and provisions for reuse, recycling or disposal, including antimicrobial substances.

9. Equipment and instruments

- 9.1 The SU should provide a list (or similar document) of equipment and instruments involved in production, filling, packing, quality control and microbiological testing. It should include the makes and models of the relevant equipment and instruments, including automated systems and those of single use, in order to ensure the evaluation of similar principles of operation.
- 9.2 A review and side-by-side comparison of the equipment and instruments, as well as process steps and parameters of the SU and RU, should be carried out in terms of their working principle, capacity, make and model to ensure that they are capable of appropriately performing the required processes and methods.
- 9.3 The facility- and building-specific location of all equipment at the RU should be considered at the time of drawing up process maps or flowcharts of the manufacturing process to be transferred, including the flow of personnel and the flow and intermediate storage of materials.

- 9.4 Where the review and comparison identify any gaps or differences, the appropriate action should be taken. This may include the adaptation of existing equipment or the acquisition of new equipment. Any modification or adaptation of existing equipment to become capable of reproducing the process being transferred should be documented.
- 9.5 Production volumes and batch sizes at the SU and RU should be compared. Where batch sizes are different, the impact should be assessed as part of risk assessment and the appropriate action planned and taken. Other factors relating to equipment to be reviewed may include:
- minimum and maximum capacity
 - material of construction of contact surfaces
 - critical operating parameters
 - components (such as filters, screens, and temperature or pressure sensors)
 - range of intended use.
- 9.6 The impact of the potential product to be transferred on existing products manufactured on site (and vice versa) should be assessed.

10. Qualification and validation

- 10.1 The extent of qualification and validation to be performed should be determined on the basis of risk management principles, taking into account the product's life cycle phase.
- 10.2 Equipment and instruments should be qualified and calibrated before using them to support the technology transfer activities.
- 10.3 Process validation should be done according to guidelines, as published in the WHO Technical Report Series (3).
- 10.4 Production processes and analytical procedures should be appropriately transferred to the RU following documented procedures. Where validation data exist, these should be included in the transfer.
- 10.5 For cleaning procedures, development and validation should be done in accordance with the guidelines published in the WHO Technical Report Series (6). Points to consider when including health-based exposure limits in cleaning validation (14) should be taken into account in establishing cleaning procedures, undertaking cleanability studies and setting acceptance limits.

- 10.6 Analytical procedures should be validated or verified according to the guidelines published in the WHO Technical Report Series (7).
- 10.7 Qualification and validation procedures, protocols, data and results should be appropriately recorded. The documents should be retained as defined in procedures.

11. Life cycle approach

- 11.1 The relevant stage of the life cycle of the facility, equipment, instrument, utility, product, process or procedure to be transferred should be taken into consideration when the transfer is planned and executed. This also applies to the control strategy and process validation.
- 11.2 The responsible entities should monitor the progress of the project at each applicable stage of the life cycle aspect of the transfer to ensure successful completion of the transfer.

12. Phases of a technology transfer project

- 12.1 The technology transfer project plan may be divided into different phases. These may include:
- Phase I: Project initiation
 - Phase II: Project planning
 - Phase III: Project transfer execution
 - Phase IV: Project review and closeout.

Phase I: Project initiation

- 12.2 During the initiation phase of the project, a unit normally identifies the need for the technology transfer. This may be due to a lack of capacity, a transfer from development to commercial site or a transfer from one company to another.
- 12.3 During an initial discussion, it should be identified whether or not an RU has any interest in such a project (see also the section on due diligence above).
- 12.4 The RU should be able to accommodate the intended activity.
- 12.5 The RU should have the necessary technical expertise, technology and capability.

- 12.6 A sufficient level and depth of detail to support the activity, and any further development and optimization at the RU, should be transferred.

Phase II: Project planning

- 12.7 The marketing authorization holder, SU and RU should jointly establish a team that will coordinate activities and execute the technology transfer exercise. Where the technology transfer involves a site that has limited manufacturing experience or the process being transferred is complex, the SU should consider providing extensive training and on-site support before the project execution phase begins.
- 12.8 The team should perform a gap analysis and risk assessment based on the available data, information and knowledge of the premises, equipment, materials, products, procedures and other related information.
- 12.9 The team should prepare the technology transfer document, such as the master plan or technology transfer protocol.
- 12.10 The team should develop a control strategy that includes:
- risks
 - raw, starting and packaging material attributes
 - analytical and microbiological test procedures
 - sampling plans and release and stability specifications
 - critical quality attributes, critical process parameters and in-process controls
 - acceptance criteria and limits.
- 12.11 The specifications and critical material attributes of the starting materials (APIs and excipients) to be used at the RU should be consistent with those materials used at the SU unless there is a planned change associated with these materials as part of the transfer and regulatory approval is obtained, as applicable. Documentation to support compliance with transmissible animal spongiform encephalopathy certification requirements, or other regulatory requirements, should be present at the RU, where applicable.
- 12.12 The SU should provide the RU with the open part of the drug master file or API master file, as applicable, or equivalent information, as well as any relevant additional information on the API of importance to the manufacture of the pharmaceutical product.

- 12.13 The SU should provide to the RU product information, including its qualitative and quantitative composition, physical description, method of manufacture, in-process controls, control method and specifications, packaging components and configurations, and any safety and handling considerations.
- 12.14 The marketing authorization holder or SU should provide any information on the history of process development as well as any historical process changes that may be required to enable the RU to perform any further development or process optimization after successful transfer.
- 12.15 The SU should provide to the RU information on any health, safety and environmental issues associated with the manufacturing processes to be transferred and the implications thereof (for example, need for gowning or protective clothing).
- 12.16 The SU should provide to the RU information on current processing and testing, including:
- a detailed description of facility requirements and equipment;
 - information on starting materials, applicable material safety data sheet where required, and storage and distribution requirements for raw materials, intermediates and finished products;
 - description of manufacturing steps (narrative and process maps or flowcharts and master batch records), including the qualification of in-processing hold times and conditions, and the order and method of raw material addition and bulk transfers between processing steps;
 - description of analytical procedures;
 - identification and justification of control strategy (for example, identification of critical performance aspects for specific dosage forms, identification of process control points, product quality attributes and qualification of critical processing parameter ranges, sampling plans, and statistical process control charts);
 - design space, in cases where this has been defined;
 - validation information (such as validation plans and reports);
 - annual product quality reviews;
 - stability information;
 - an authorized set of protocols and work instructions for manufacturing;

- environmental conditions or any special requirement needed for the facility or equipment, depending on the nature of the product to be transferred.
- 12.17 Information on packaging to be transferred from the SU to the RU should include specifications for a suitable container and closure system, as well as any relevant additional information on design, packing, processing or labelling requirements and tamper-evident and anticounterfeit measures.
- 12.18 For quality control and microbiological testing of packaging components, specifications should be provided, including drawings, artwork and material and reference to relevant pharmacopoeias, where applicable.

Phase III: Project transfer execution

- 12.19 The team should execute the project in accordance with the procedures and agreed plan.

Production (example: finished pharmaceutical product)

- 12.20 During the transfer process, the RU should identify any differences in facilities, systems and capabilities and discuss these with the SU. The SU should cooperate with the RU to understand the potential impact and satisfactorily address this in order to assure equivalent product quality. Based on the information received from the SU, the RU should consider its own capability to manufacture and pack the product to the required standards and should develop the relevant site operating procedures and documentation before the start of routine production.
- 12.21 The RU should address the following tasks:
- comparison and assessment of suitability and qualification of facility and equipment;
 - description of manufacturing process and flow of personnel and of materials at the RU (narrative or process maps or flowcharts);
 - determination of critical steps in manufacture, including hold times, end-points, sampling points and sampling techniques;
 - writing and approval of a training plan and standard operating procedures for all production operations (for example, dispensing, granulation or blending or solution preparation, tablet compression, tablet coating, encapsulation, liquid filling, primary and secondary packaging and in-process quality control and microbiology), packaging, cleaning, testing and storage;

- evaluation of stability information, with generation of site-specific stability data if required;
- compliance with regulatory requirements for any changes made that may impact the quality and efficacy of the product.

12.22 The transfer of packaging operations should follow the same procedural principles as those of the product processing.

12.23 The RU should determine the need for qualification and validation for the packaging process.

Quality control: analytical procedure transfer

12.24 Analytical procedures used to test pharmaceutical products, starting materials, packaging components and cleaning (residue) samples, if applicable, should be implemented at the testing laboratory before the testing of samples for process validation studies is performed by the RU. The transfer of the analytical procedure may be accomplished by several approaches, such as confirmation testing, comparability testing between SU and RU results, co-validation between laboratories, or through paper-based knowledge transfer. The strategy chosen should be risk based and scientifically justifiable.

12.25 A protocol and test transfer plan defining the steps should be prepared for the transfer of analytical procedures. The analytical procedures transfer protocol should include:

- a description of the objective, scope and responsibilities of the SU and the RU;
- a specification of materials and methods;
- the experimental design and acceptance criteria;
- documentation (including information to be supplied with the results and report forms to be used, if any);
- procedure for the handling of deviations;
- details of test samples (starting materials, intermediates and finished products).

12.26 The SU's responsibilities for the transfer of analytical procedures typically are to:

- provide method-specific training for analysts and other quality control and microbiology staff, if required;
- assist in analysis of quality control and microbiology testing results;

- define all procedures to be transferred for testing a given product, starting material or cleaning sample;
- define experimental design, sampling methods and acceptance criteria;
- provide any validation reports for procedures under transfer, including proof of their robustness;
- provide details of the equipment used, as necessary (part of the validation report, if available) and any standard test samples;
- provide approved procedures used in testing;
- review and approve transfer reports.

12.27 The RU should exercise its responsibility to:

- review analytical procedures provided by the SU, and formally agree on acceptance criteria before execution of the transfer protocol;
- ensure that the necessary equipment for quality control is available and qualified at the RU site, and that the equipment used by the RU during the analytical transfer meets the appropriate specifications in order to ensure the requirements of the procedure or specification are met;
- ensure that adequately trained and experienced personnel are in place for analytical testing;
- provide a documentation system capable of recording receipt and testing of samples to the required specification using approved test procedures, and of reporting, recording and collating data and designation of status (approved, rejected, quarantine);
- execute the transfer protocol;
- perform the appropriate level of validation or verification to support the implementation of the procedures;
- generate and obtain approval of transfer reports.

12.28 The appropriate training should be provided and all training activities and outcomes should be documented.

12.29 Reference should be made to recognized compendial monographs, where these are relevant.

12.30 An experimental design should be prepared that includes acceptance criteria for the analytical testing procedures.

12.31 Where products are transferred from one unit to another, the applicable analytical procedures should also be transferred.

- 12.32 Relevant analytical procedure development and validation documentation should be made available by the SU to the RU, if required.
- 12.33 The appropriate transfer protocols and procedures should be followed when analytical procedures are transferred.
- 12.34 The number of analysts involved in the transfer, from both SU and RU, should be defined and justified.
- 12.35 The parameters to be included in the experimental evaluation of the transfer of the analytical procedure should be defined and justified.
- 12.36 Acceptance criteria should be set to determine the success of the transfer and capability of the process and procedures; where appropriate, statistical trending of results should be undertaken in order to demonstrate this.

Cleaning

- 12.37 To minimize the risk of contamination and cross-contamination, adequate cleaning procedures should be followed.
- 12.38 Cleaning procedures and their validation should normally be site specific. In order for the RU to define its cleaning strategy, the SU should provide information on cleaning at the SU to minimize cross-contamination due to residues from previous manufacturing steps, operator exposure and environmental impact, including:
- information on cleanability;
 - information on solubility of active ingredients, excipients and vehicles;
 - toxicological assessment, including health-based exposure limits;
 - existing cleaning procedures.
- 12.39 Additional applicable information should be provided, such as:
- cleaning validation reports (chemical and microbiological);
 - potential degradation products and impurities;
 - risks of antimicrobial resistance;
 - information on cleaning agents used (efficacy, evidence that they do not interfere with analytical testing for residues of APIs, removal of residual cleaning agents);
 - recovery studies to validate the sampling methodology.

- 12.40 Before the transfer, the SU should provide information on limits for product residues and the rationale for limit selection.
- 12.41 Based on the information provided by the SU, cleaning procedures should be designed at the RU, considering relevant characteristics of the residues to be cleaned (such as potency, toxicity and solubility), manufacturing equipment design and configuration, and cleaning agent.

Phase IV: Project review and close-out

- 12.42 The progress and success of the technology transfer should be monitored and reviewed during and after completion of the project. The review should further ensure that, as appropriate, stability studies are started and continued; post-marketing commitments are monitored; and new material suppliers are integrated into the quality management system.
- 12.43 Compliance with the procedures and protocols should be verified. Deviations and changes should be documented and investigated, where appropriate.
- 12.44 Where possible, data and results should be subjected to appropriate statistical calculation and evaluation to determine trends and compliance with control limits and capability studies.
- 12.45 A document such as a technology transfer report should be prepared, based on the data and information obtained during the project. The supportive data should be stored and should be accessible.
- 12.46 The document, which should include an assessment of the data and information and a conclusion, should be authorized by the appropriate responsible person or persons. It should further state whether or not the team has achieved the completion of the technical transfer. Any deviations and changes from the master plan should additionally be assessed and evaluated before close-out of the project.

References

1. WHO guidelines on transfer of technology in pharmaceutical manufacturing. In: WHO Expert Committee on Specifications for Pharmaceutical Preparations: forty-fifth report. WHO Technical Report Series No. 961, Annex 7. Geneva: World Health Organization; 2011.
2. WHO good manufacturing practices for pharmaceutical products: main principles. In: WHO Expert Committee on Specifications for Pharmaceutical Preparations: forty-eight report. WHO Technical Report Series No. 986, Annex 2. Geneva: World Health Organization; 2014.

3. WHO good manufacturing practices: guidelines on validation. In: WHO Expert Committee on Specifications for Pharmaceutical Preparations: fifty-third report. WHO Technical Report Series No. 1019, Annex 3. Geneva: World Health Organization; 2019.
4. Guidelines on heating, ventilation and air-conditioning systems for non-sterile pharmaceutical products. Part 2: interpretation of guidelines. In: WHO Expert Committee on Specifications for Pharmaceutical Preparations: fifty-third report. WHO Technical Report Series No. 1019, Annex 2. Geneva: World Health Organization; 2019.
5. Good manufacturing practices: guidelines on validation. Appendix 2: Validation of water systems for pharmaceutical use. In: WHO Expert Committee on Specifications for Pharmaceutical Preparations: fifty-third report. WHO Technical Report Series No. 1019, Annex 3. Geneva: World Health Organization; 2019.
6. Good manufacturing practices: guidelines on validation. Appendix 3: Cleaning validation. In: WHO Expert Committee on Specifications for Pharmaceutical Preparations: fifty-third report. WHO Technical Report Series No. 1019, Annex 3. Geneva: World Health Organization; 2019.
7. Good manufacturing practices: guidelines on validation. Appendix 4: Analytical procedure validation. In: WHO Expert Committee on Specifications for Pharmaceutical Preparations: fifty-third report. WHO Technical Report Series No. 1019, Annex 3. Geneva: World Health Organization; 2019.
8. Good manufacturing practices: guidelines on validation. Appendix 5: Validation of computerized systems. In: WHO Expert Committee on Specifications for Pharmaceutical Preparations: fifty-third report. WHO Technical Report Series No. 1019, Annex 3. Geneva: World Health Organization; 2019.
9. Good manufacturing practices: guidelines on validation. Appendix 6: Guidelines on qualification. In: WHO Expert Committee on Specifications for Pharmaceutical Preparations: fifty-third report. WHO Technical Report Series No. 1019, Annex 3. Geneva: World Health Organization; 2019.
10. Guidelines on good manufacturing practices: validation. Appendix 7: Non-sterile process validation. In: WHO Expert Committee on Specifications for Pharmaceutical Preparations: forty-ninth report. WHO Technical Report Series No. 992, Annex 3. Geneva: World Health Organization; 2015.
11. WHO guidelines on quality risk management. In: WHO Expert Committee on Specifications for Pharmaceutical Preparations: forty-seventh report. WHO Technical Report Series No. 981, Annex 2. Geneva: World Health Organization; 2013.
12. Guidance on good data and record management practices. In: WHO Expert Committee on Specifications for Pharmaceutical Preparations: fiftieth report. WHO Technical Report Series No. 996, Annex 5. Geneva: World Health Organization; 2016.
13. Guideline on data integrity. In: WHO Expert Committee on Specifications for Pharmaceutical Preparations: fifty-fifth report. WHO Technical Report Series No. 1033, Annex 4. Geneva: World Health Organization; 2021.
14. Points to consider when including health-based exposure limits (HBELs) in cleaning validation. In: WHO Expert Committee on Specifications for Pharmaceutical Preparations: fifty-fifth report. WHO Technical Report Series No. 1033, Annex 2. Geneva: World Health Organization; 2021.
15. A risk-based identification of essential medicines for local manufacturing in low- and middle-income countries: draft for comments. Working document QAS/16.682. Geneva: World Health Organization; 2016.

Further reading

- European Medicines Agency. 2014. Guideline on setting health-based exposure limits for use in risk identification in the manufacture of different medicinal products in shared facilities. EMA/CHMP/CVMP/SWP/169430/2012.
- European Medicines Agency. 2018. Questions and answers on implementation of risk-based prevention of cross-contamination in production.
- European Medicines Agency. 2020. Reflection paper on good manufacturing practice and marketing authorisation holders. EMA/457570/2019.
- International Conference on Harmonisation of Technical Requirements for Registration of Pharmaceuticals for Human Use. 2005. Quality risk management. ICH harmonised guideline Q9, current step 4 version, 9 November 2005.
- International Conference on Harmonisation of Technical Requirements for Registration of Pharmaceuticals for Human Use. 2009. Pharmaceutical development. ICH harmonised guideline Q8(R2), current step 4 version, August 2009.
- International Conference on Harmonisation of Technical Requirements for Registration of Pharmaceuticals for Human Use. 2012. Development and manufacture of drug substances (chemical entities and biotechnological/biological entities). ICH harmonised guideline Q11, current step 4 version, 1 May 2012.
- International Conference on Harmonisation of Technical Requirements for Registration of Pharmaceuticals for Human Use. 2019. Technical and regulatory considerations for pharmaceutical product life cycle management. ICH harmonised guideline Q12, final version, 20 November 2019.
- International Medical Device Regulators Forum. 2018. Essential principles of safety and performance of medical devices and IVD medical devices.
- International Society for Pharmaceutical Engineering. 2018. Good practice guide: technology transfer, third edition.
- Parental Drug Association. 2014. Technical report No. 65: technology transfer.

Appendix 1

Documentation commonly required for technology transfer

Table 1 provides examples of the documentation commonly required for technology transfer. Note that these are examples: all the required documents should be identified for the different tasks.

Table 1
Documentation commonly required for technology transfer

Aspect	Related documentation
Regulatory	Regulatory process description Applicable regulatory documentation
Starting materials (active pharmaceutical ingredients (APIs) and excipients)	Drug master file, API master file, active substance master file Material safety data sheets Product development report Storage conditions Stability data Forced stability data Specifications Supplier qualification References
Formulation	Formulation development reports Master formula Material compatibility and interaction studies Specifications for delivery devices
Batch manufacturing	Master of executed batch record Scale-up information Risk assessment Critical process parameters In-process control specification Scale-up protocol and report Process validation

Table 1 *continued*

Aspect	Related documentation
Packaging	Packaging material specification Master of executed packaging record Validation Sampling plan Acceptance quality level for products and defects Packaging validation
Finished product	Specification Product dossier
Analytical procedures	Analytical test procedures Analytical procedure development Analytical procedure validation Standard test procedures Instrument specifications
Quality control	Sampling procedures (e.g. in-process control) Stability testing protocol and procedures Release test analytical procedure validation
Equipment and instruments	List of equipment and instruments Preventive maintenance information Overview of qualification
Cleaning	Cleaning validation master plan Cleaning procedure development and cleanability Cleaning procedures Health-based exposure level (permitted daily exposure) information reports Analytical procedures validation for cleaning Cleaning validation reports and recovery study reports
Other documents	Recalls and complaint reports Bio-batch information Pilot batch information History of changes and change management Hold time protocols and reports

Annex 5

WHO good manufacturing practices for medicinal gases

Contents

1. Introduction	226
2. Scope	227
3. Glossary	227
4. Quality management	229
5. Personnel	230
6. Documentation	231
7. Complaints	233
8. Recalls	233
9. Returns	234
10. Self-inspection, quality audits and supplier audits and approvals	234
11. Premises	235
12. Equipment and utilities	236
13. Qualification and validation	237
14. Production	237
15. Quality control	243
16. Product life cycle and continuous improvement	245
17. Storage and distribution	246
References	247



1. Introduction

- 1.1 Arising from an increased demand for medicinal gases, in particular the use of oxygen in the treatment of patients with coronavirus disease 2019 (COVID-19), the World Health Organization (WHO) Health Products Policy and Standards Department (formerly Essential Medicines and Health Products) and other departments involved in the supply of oxygen and the inspection of production sites of medicinal gases raised the urgency for the preparation of the *WHO good manufacturing practices for medicinal gases* guidance text.
- 1.2 There is an urgent need to scale up the production of medicinal gases, in particular oxygen, meeting the required quality specifications. Where the good manufacturing practices (GMP) standards for medicinal gases are not followed, for example in the production and control of industrial oxygen, the purity and content of oxygen could be affected. The possible contamination of industrial oxygen with viable and non-viable particulate matter, including other impurities, could result in risk to patients when applied for medicinal use. Industrial oxygen should not be used as a medicinal gas.
- 1.3 Although there are other published guidelines, such as those of the European Union and the Pharmaceutical Inspection Co-operation Scheme (PIC/S), the COVID-19 pandemic resulted in an urgent and increased need for the rational use of oxygen and medicinal gases in many WHO Member States.
- 1.4 Whilst the urgent supply of medicinal gases is necessary, appropriate standards should be followed in all countries for the production, control, storage and distribution of oxygen and other medicinal gases to guarantee that gases for medicinal use are of assured quality when they reach the patients.
- 1.5 The recommendations in this guideline are harmonized with the principles of other similar and published guidelines.
- 1.6 WHO GMP guidelines are reviewed and updated regularly, and are available in the WHO Technical Report Series. Manufacturers and distributors of medicinal gases should comply with the relevant parts of WHO GMP guidelines as well as with the content of this document. For ease of reference, a list of some applicable guidelines, such as those reflecting the principles of GMP for active pharmaceutical ingredients (1), the main principles of GMP (2), water for pharmaceutical use (3), data integrity (4), good practices for pharmaceutical quality control laboratories (5), good storage and distribution practices (6), and others (7–15), are referenced below.

2. Scope

- 2.1 This guideline focuses on the production, control, storage and distribution of medicinal gases.
- 2.2 This document does not cover the manufacture of medicinal gases in hospitals or at home for personal use. However, the principles contained in this document may be applied in those instances to ensure that oxygen generated at hospitals or at home is suitable for intended use and meets the appropriate quality standards.

3. Glossary

The definitions given below apply to the terms used in these guidelines. They have been aligned as much as possible with the terminology in related WHO guidelines and good practices and included in the WHO *Quality Assurance of Medicines Terminology Database: list of terms and related guideline*,¹ but may have different meanings in other contexts.

active substance gas. Any gas intended to be an active substance for a medical product or medicinal gas.

air separation. The separation of atmospheric air into its constituent gases.

compressed gas. A gas that, when packaged under pressure for transport, is entirely gaseous at -50°C ; this category includes all gases with a critical temperature less than or equal to -50°C .

container. A cryogenic vessel (tank, tanker or other type of mobile cryogenic vessel), a cylinder, a cylinder bundle or any other package that is in direct contact with a gas.

cryogenic gas. A gas that liquefies at 1.013 bar at temperatures below -150°C .

cylinder. A container, usually cylindrical, suited for compressed, liquefied or dissolved gas, fitted with a device to regulate the spontaneous outflow of gas at atmospheric pressure and room temperature.

cylinder bundle. An assembly of cylinders that are fastened together, interconnected by a manifold, transported and used as a unit.

¹ https://www.who.int/docs/default-source/medicines/norms-and-standards/guidelines/mqa-terminology-sept-2020.pdf?sfvrsn=48461cfc_5.

evacuate. To remove residual gas from a container or system to a vacuum level of 0.84 bar absolute at sea level using a vacuum system.

gas. Any substance that is completely gaseous at 1.013 bar and +20 °C or has a vapour pressure exceeding 3 bar at +500 °C.

home cryogenic vessel. A mobile cryogenic vessel designed to hold liquid oxygen and dispense gaseous oxygen at a patient's home.

hydrostatic pressure test. A test performed, as required by national or international regulations, in order to ensure that pressure containers are able to withstand pressures up to the container's design pressure.

liquefied gas. A gas that, when packaged for transport, is partially liquid (or solid) at a temperature above -50 °C.

manifold. Equipment or apparatus designed to enable one or more gas containers to be emptied and filled at the same time.

maximum theoretical residual impurity. A gaseous impurity coming from a possible backflow that remains after a cylinder's pretreatment before filling. The calculation of the maximum theoretical residual impurity is only relevant for compressed gases and supposes that these gases act as perfect gases.

medicinal gas. Any gas or mixture of gases classified as a medical product.

minimum pressure retention valve. A cylinder valve that maintains a positive pressure above atmospheric pressure in a gas cylinder after use in order to prevent any internal contamination of the cylinder.

mobile cryogenic vessel. A mobile thermally insulated container designed to maintain the contents in a liquid state.

non-return valve. A valve that permits flow in one direction only.

purge. To remove the residual gas from a container or system by first venting the residual gas from the container or system, then pressurizing the container or system to 2 bar and thereafter venting the gas used for purging to 1.013 bar.

tank. A static thermally insulated container designed for the storage of liquefied or cryogenic gas (also called a fixed cryogenic vessel).

tanker. A thermally insulated container fixed on a vehicle for the transport of liquefied or cryogenic gas.

valve. A device for opening and closing containers.

vent. To remove the residual gas from a container or system down to 1.013 bar by opening the container or system to the atmosphere.

4. Quality management

- 4.1 Companies that are involved in the manufacture, control, storage and distribution of medicinal gases should document, implement and maintain a comprehensively designed and clearly defined quality management system. This is the responsibility of senior management.
- 4.2 Senior management should also assume responsibility for the quality of the medicinal gases manufactured, controlled, released, stored and distributed.
- 4.3 All parts of the quality system should be adequately resourced and maintained.
- 4.4 The quality system should incorporate the principles of good practices (GxP), which should be applied to the life cycle stages of medicinal gases. This includes steps such as the receipt of materials, manufacturing, filling, testing, release, distribution and return of the container after use of a medicinal gas.
- 4.5 The quality system should ensure that:
 - medicinal gases are manufactured, controlled, stored and distributed in accordance with the recommendations in this document and other associated guidelines, such as good-quality control laboratory practices and good storage and distribution practices, where appropriate;
 - managerial roles, responsibilities and authorities are clearly specified in job descriptions;
 - operations and other activities are clearly described in a written form, such as standard operating procedures (SOPs) and work instructions;
 - supplier qualification is carried out and quality agreements are in place;
 - arrangements are made for the supply and use of the correct containers and labels;
 - all necessary controls are in place;
 - there is a system for quality risk management;
 - calibrations and validations are carried out where necessary;

- the finished product is correctly processed and checked according to the defined procedures and specifications;
- deviations, suspected product defects, out-of-specification test results and any other non-conformances or incidents are reported, investigated and recorded, and an appropriate level of root cause analysis is applied during such investigations in order to identify the most likely root cause;
- proposed changes are evaluated and approved prior to implementation, considering regulatory notification and approval where required; after implementation of any such change, an evaluation should be undertaken to confirm that the quality objectives were achieved and that there was no unintended adverse impact on product quality;
- appropriate corrective and preventive actions are identified and taken where required processes are in place to ensure the management of any outsourced activities that may impact product quality and integrity;
- finished products are not released and supplied before the authorized person has certified that each production batch has been manufactured and controlled in accordance with product specifications, the recommendations in this document and any other regulations relevant to the production, control and release of these products;
- there is a system for handling complaints, returns and recalls from the market;
- there is a system for self-inspection;
- satisfactory arrangements exist to ensure that medicinal gases are filled, stored, distributed and subsequently handled so that their quality is maintained.

4.6 The system for quality risk management should cover a systematic process for the assessment, control, communication and review of risks in the production, filling, control, storage and distribution of medicinal gases and, ultimately, protect the patient from receiving a wrong or contaminated product.

5. Personnel

5.1 Personnel involved in the manufacture, control, certification or release of a batch, storage and distribution of medicinal gases should possess

qualifications, such as a diploma or degree in, for example, pharmacy, engineering or pharmaceutical sciences, and should have practical experience appropriate for their required duties. They should undergo medical examinations prior to employment and at periodic intervals thereafter, if required by national legislation.

- 5.2 Personnel should receive the appropriate training in relevant guidelines covering GxP and company procedures.
- 5.3 Personnel should be aware of potential hazards and risks to products and patients.
- 5.4 Personnel of outsourced service providers should be appropriately trained, especially where activities could influence the quality of medicinal gases and containers, such as the maintenance and cleaning of cylinders or valves.

6. Documentation

- 6.1 Specifications, SOPs and related documents, as appropriate for the manufacture, control, storage, and distribution of medicinal gases, should be established, implemented and maintained in accordance with the quality management system.
- 6.2 Documents should be designed, prepared, reviewed and distributed with care, in accordance with the quality management system.
- 6.3 Documents should be authorized (approved, signed and dated) by the appropriate responsible persons. No document should be changed without prior authorization and approval.
- 6.4 Documents should have unambiguous content and be laid out in an orderly fashion. The title, nature and purpose should be clearly stated.
- 6.5 Documents should be periodically reviewed and kept up to date.
- 6.6 Superseded documents should not be used.
- 6.7 Where documents require the entry of data, those entries should be clear, legible and indelible, in compliance with good documentation practices and data integrity requirements.
- 6.8 Records should be made or completed when any action is taken and in such a way that all significant activities are traceable. Records should be retained for a period of time as defined by internal procedures or national legislation, as appropriate.

- 6.9 Labels should be clear, unambiguous and in compliance with national or regional legislation, as appropriate (16, 17).
- 6.10 Labels on the cylinders of medicinal gases should contain at least the information as recommended in the pharmacopoeia, where applicable, as well as the following information:
- the name of the medicinal gas
 - the batch number assigned by the manufacturer
 - the expiry or use-before date, if applicable
 - any special storage conditions or handling precautions that may be necessary
 - directions for use
 - warnings and precautions
 - the name and address of the manufacturer
 - test date (month and year).
- 6.11 Authorized specifications and testing procedures should be available.
- 6.12 Records should be maintained for each batch of gas manufactured.

Standard operating procedures and records

- 6.13 SOPs and associated records should be available for at least:
- equipment
 - analytical apparatus and instruments
 - maintenance and calibration
 - cleaning and sanitization
 - personnel matters such as training, clothing and hygiene
 - qualification and validation
 - self-inspection
 - complaints
 - recalls
 - returns.
- 6.14 The SOPs for sampling should specify the person or persons authorized to take samples and the sampling instructions.

- 6.15 The SOPs describing the details of the batch (lot) numbering system should ensure that each batch of medicinal gas is identified with a specific batch number.
- 6.16 Records of analysis should be maintained.
- 6.17 Written release and rejection procedures should be available, in particular for the release of the finished product for sale.
- 6.18 Records should be maintained of the distribution of each batch of medicinal gas.
- 6.19 Records should be maintained for major and critical equipment, as appropriate, of any qualifications, calibrations, maintenance, cleaning or repair operations, including the dates and the identities of the people who carried out those operations.

7. Complaints

- 7.1 There should be a written procedure describing the handling of complaints.
- 7.2 Any complaint concerning a defect of a medicinal gas should be recorded in detail and thoroughly investigated.
- 7.3 Where necessary, the appropriate follow-up action should be taken after the investigation and evaluation of a complaint. Where necessary, a recall of the batch or batches should be considered.
- 7.4 All decisions made and measures taken as a result of a complaint should be recorded and referenced to the corresponding batch records.
- 7.5 The competent authorities should be informed if a manufacturer is considering action following the identification of serious quality problems with a medicinal gas that may be impacting patients.

8. Recalls

- 8.1 There should be a written, authorized procedure describing the managing of a recall of medicinal gases.
- 8.2 The competent authority of the countries in which a product is recalled or withdrawn from the market should be notified.
- 8.3 The recall of a medicinal gas should be documented. Records should be kept.

9. Returns

- 9.1 There should be a written authorized procedure describing the managing of returns of medicinal gases, which may include inspection or testing.
- 9.2 Once distributed, medicinal gases may only be returned under agreed conditions, as defined by the manufacturer.
- 9.3 Returned medicinal gases should be stored in a controlled manner, in a dedicated area. Returned goods should be clearly identified and kept until a decision is made as to what should be done with the returned goods.
- 9.4 Inventory records of returned medicinal gases should be kept.

10. Self-inspection, quality audits and supplier audits and approvals

- 10.1 Self-inspections should be carried out according to a written, authorized procedure. The objective should be to detect any shortcomings in the implementation of GMP and to recommend the necessary corrective actions.
- 10.2 Self-inspections should be performed routinely and, in addition, may be performed on special occasions.
- 10.3 Self-inspections should be done by a team of personnel with knowledge of the manufacture and control of medicinal gases and who are qualified to evaluate compliance with GxP.
- 10.4 Self-inspections should cover, for example:
 - personnel
 - premises
 - maintenance
 - equipment
 - production
 - quality control
 - documentation, including label control
 - sanitation and hygiene
 - validation and qualification
 - calibration
 - batch release

- recall procedures
- complaints management
- results of previous self-inspections and any corrective steps taken.

- 10.5 A report should be made at the completion of a self-inspection.
- 10.6 Appropriate recommendations for corrective actions should be implemented and an effective follow-up programme should be implemented. The effectiveness of corrective action taken should be verified.
- 10.7 Self-inspections may be supplemented by a quality audit and conducted by outside or independent specialists. The qualifications of external auditors should be documented.
- 10.8 Suppliers and contractors should be evaluated before they are approved and included in the approved list. The evaluation should consider a supplier's or contractor's history and the nature of the materials to be supplied or services to be contracted. If an audit is required, it should determine the supplier's or contractor's ability to conform with GMP or the applicable standards.

11. Premises

- 11.1 The premises where medicinal gases are manufactured should be located, designed, constructed and maintained to suit the operations to be carried out.
- 11.2 The layout and design of the premises should aim to minimize the risk of errors, mix ups, contamination and cross-contamination. In addition, it should allow effective cleaning and maintenance without any adverse effect on the quality of the products.
- 11.3 The premises should provide sufficient space for manufacturing, quality control testing and storage operations.
- 11.4 There should be:
- separate marked areas for different gases;
 - clear identification and segregation of cylinders and mobile cryogenic vessels at various stages of processing (for example, "filled cylinders/mobile cryogenic vessels", "awaiting checking", "awaiting filling", "quarantine", "certified", "rejected", "prepared deliveries", "empty cylinders/home cryogenic vessels").

Note: The method used to achieve these various levels of segregation will depend on the nature, extent and complexity of the overall operation. Marked-out floor areas, partitions, barriers, signs, labels or other appropriate means could be used. The segregation of the products may be achieved electronically using a validated electronic system as long as the standards for the cylinders and the vessels intended for medicinal gases are maintained.

- 11.5 Filled cylinders or mobile cryogenic vessels should be stored and transported in a safe manner that ensures that they will be delivered in a clean state, compatible with the environment in which they will be used. Specific storage conditions should be provided as required (for example, for gas mixtures where phase separation occurs upon freezing).

12. Equipment and utilities

- 12.1 Equipment and utilities should be selected, located, constructed and maintained to suit the operations to be carried out.
- 12.2 The layout, design, installation and use of equipment and utilities should aim to minimize the risk of errors and permit effective cleaning and maintenance in order to avoid cross-contamination, build-up of dust or dirt and, in general, any adverse effect on the quality of products.
- 12.3 Equipment should be designed to ensure that the correct gas is filled into the correct container. There should normally be no cross-connections between pipelines carrying different gases. If cross-connections are needed (for example, when filling equipment with mixtures), qualification and controls should ensure that there is no risk of cross-contamination between the different gases. In addition, the manifolds should be equipped with specific connections. These connections may be subject to international or national standards. The use of connections meeting different standards at the same filling site should be carefully controlled, as well as the use of adaptors needed in some situations to bypass the specific fill connection systems.
- 12.4 Tanks and tankers should be dedicated to a single and defined type and quality of gas. Where non-dedicated tanks and tankers are used, risks of contamination should be assessed and controlled, including through the application of the same GxP in the production and having the same quality specification for industrial and medicinal gas.

- 12.5 A common system supplying gas to medicinal and industrial gas manifolds is only acceptable if there is a validated method to prevent backflow from the industrial gas line to the medicinal gas line.
- 12.6 Filling and distribution manifolds should be dedicated to a single medicinal gas or to a given mixture of medicinal gases. In exceptional cases, filling gases used for other gases or other than medical purposes may be acceptable on manifolds dedicated to medicinal gases if justified and performed under control. In these cases, the quality of that gas or mixture of gases should be at least equal to the required quality of the medicinal gas, and GMP standards should be maintained. Filling should then be carried out by campaigns.
- 12.7 Repair, maintenance, cleaning and purging operations of equipment should not adversely affect the quality of the medicinal gases. Procedures should describe the measures to be taken after repair and maintenance operations involving breaches of the system's integrity. It should be demonstrated that the equipment is free from any contamination that may adversely affect the quality of the finished product before releasing it for use. Records should be maintained.
- 12.8 A procedure should describe the measures to be taken when a tanker is taken back into medicinal gas service, for example, after transporting industrial gas or after a maintenance operation. This should include, for example, a change in service documentation and analytical testing. The methods should be validated.

13. Qualification and validation

- 13.1 The scope and extent of qualification and validation should be determined based on risk management principles.
- 13.2 Risk assessment should be carried out and should cover, for example, the premises, equipment, processing, filling, storage and distribution of medicinal gases.
- 13.3 Authorized procedures, protocols and records should be maintained.

14. Production

- 14.1 The manufacturing of medicinal gases should generally be carried out in closed equipment.

Note: Active substance gases can be prepared by chemical synthesis or be obtained from natural sources followed by purification steps, if necessary (for example, in an air separation plant). Where air separation is used to manufacture active substance gases, the manufacturer should ensure that the ambient air is appropriate for the established process. Changes in ambient air quality should be documented and evaluated.

- 14.2 Controls should be identified and implemented to exclude the risks of contamination.
- 14.3 Manufacturing data and information should be included in the records for each batch of cylinders or mobile cryogenic vessels produced.
- 14.4 Records should be maintained for each batch of gas manufactured. These records should include relevant information, as appropriate, such as the following:
 - name of the product;
 - batch number;
 - identification of the person or persons carrying out each significant step;
 - equipment used (such as filling manifold);
 - quantity of cylinders or mobile cryogenic vessels before filling, including individual identification references and water capacity;
 - prefilling operations performed;
 - key parameters that are needed to ensure correct fill at standard conditions;
 - results of appropriate checks to ensure the containers have been filled;
 - specification of the finished product and the results of quality control tests (including reference to the calibration status of the test equipment);
 - quantity of rejected cylinders or mobile cryogenic vessels with individual identification references and reasons for rejection;
 - details of any problems or unusual events and signed authorization for any deviation from instructions;
 - batch label, where applicable;
 - specification of the finished product and results of quality control tests (including reference to the calibration status of the test equipment) by the responsible person, with date and signature;

- batch quantity;
 - date of testing and certification statement;
 - identification reference for the tank (tanker) in which the batch is certified;
 - reference to the supplying tanker (tank), reference to the source gas, as applicable.
- 14.5 Each filled cylinder should be traceable to significant aspects of the production and filling operations.
- 14.6 Cylinders and mobile cryogenic vessels should be checked, prepared, filled and stored in a manner that will prevent mix-ups. Controls should be appropriate and may include labelling, colour coding, signage or separate areas to facilitate segregation of industrial and medicinal cylinders and vessels.
- 14.7 There should be no exchange of cylinders or mobile cryogenic vessels used for medicinal and industrial gases in or from these areas, unless all comply with the specifications of medicinal gases and the manufacturing operations are performed according to GMP standards.
- 14.8 Production through a continuous process, such as air separation, should be continuously monitored for quality. The results of this monitoring should be kept in a manner permitting trend evaluation.
- 14.9 The transfer and delivery of active substance gases in bulk should comply with the same requirements as those for medicinal gases.
- 14.10 The filling of active substance gases into cylinders or into mobile cryogenic vessels should comply with the same requirements as those for medicinal gases.
- 14.11 Requirements applying to cylinders should also apply to cylinder bundles (except storage and transportation under cover).
- 14.12 Records should be maintained for each batch of gas transferred to tankers. These records should include relevant information, as appropriate, such as the following:
- name of the product;
 - batch number;
 - identification reference for the tank (tanker) in which the batch is certified;

- date and time of the filling operation;
- identification of the person or persons carrying out the filling of the tank (tanker);
- identification of the person or persons carrying out each significant step (such as line clearance, receipt, preparation before filling, filling);
- reference to the supplying tank (tanker) and reference to the source gas, as applicable;
- relevant details concerning the filling operation;
- equipment used (such as filling manifold);
- prefilling operations performed;
- key parameters that are needed to ensure correct fill at standard conditions;
- a sample of the batch label;
- specification of the finished product and results of quality control tests (including reference to the calibration status of the test equipment);
- details of any problems or unusual events, and signed authorization for any deviation from filling instructions;
- certification statement by the authorized responsible person, with date and signature.

Transfer and delivery of cryogenic and liquefied gas

- 14.13 The transfer of cryogenic or liquefied gases from primary storage, including controls before transfer, should be in accordance with validated procedures designed to avoid any contamination. Transfer lines should be equipped with non-return valves or suitable alternatives. Flexible connections and coupling hoses and connectors should be flushed with the relevant gas before use.
- 14.14 The transfer hoses used to fill tanks and tankers should be equipped with product-specific connections. The use of adaptors allowing the connection of tanks and tankers not dedicated to the same gases should be adequately controlled.
- 14.15 Delivery of gas may be added to tanks containing the same quality of gas, provided that a sample is tested to ensure that the quality of the delivered gas is acceptable. This sample may be taken from the gas to be delivered or from the receiving tank after delivery.

Filling and labelling of cylinders and mobile cryogenic vessels

- 14.16 Before filling cylinders and mobile cryogenic vessels, a batch or batches of gas or gases should be determined, controlled according to specifications, and approved for filling.
- 14.17 In the case of continuous processes, adequate in-process controls should be performed to ensure that the gas complies with specifications.
- 14.18 Cylinders, mobile cryogenic vessels and valves should conform with appropriate technical specifications and any relevant requirements by the applicable regulatory authorities. They should be dedicated to a single medicinal gas or to a given mixture of medicinal gases.
- 14.19 Cylinders should be colour coded according to relevant standards. They should preferably be fitted with minimum pressure retention valves unless other controls are in place to ensure the quality and integrity of the medicinal gas.
- 14.20 Cylinders, mobile cryogenic vessels and valves should be checked before first use in production and should be properly maintained.
- 14.21 Checks and maintenance operations should not affect the quality and the safety of the medicinal gas. The water used for the hydrostatic pressure testing carried out on cylinders should be at least of drinking quality.
- 14.22 As part of the checks and maintenance operations, cylinders should be subject to an internal visual inspection before fitting the valve to make sure they are not contaminated with water or other contaminants.
- 14.23 An internal visual inspection should be done:
- when cylinders, mobile cryogenic vessels and valves are new and initially put into medicinal gas service;
 - following any hydrostatic statutory pressure test or equivalent test where the valve is removed;
 - whenever the valve is replaced.

Note: After fitting, the valve should be kept closed to prevent any contaminant from entering the cylinder.

- 14.24 The maintenance and repair operations of cylinders, mobile cryogenic vessels and valves are the responsibility of the manufacturer of the medical product. If subcontracted, they should only be carried out by approved subcontractors, and contracts, including technical agreements,

should be established. Subcontractors should be audited to ensure that the appropriate standards are maintained.

- 14.25 Where possible, a system should be implemented to ensure the traceability of cylinders and mobile cryogenic vessels.
- 14.26 Checks to be performed before filling should be done in accordance with an authorized procedure. The following checks should be observed:
- in the case of cylinders fitted with a minimum pressure retention valve, for a positive residual pressure in each cylinder;
 - in the case of cylinders that are not fitted with a minimum pressure retention valve, to make sure it is not contaminated with water or other contaminants;
 - ensuring that all previous batch labels have been removed;
 - the removal and replacement of damaged product labels;
 - a visual external inspection of each cylinder, mobile cryogenic vessel and valve for dents, arc burns, debris, other damage, or contamination with oil or grease; cleaning should be done if necessary;
 - on each cylinder or mobile cryogenic vessel outlet connection to determine that it is the proper type for the particular gas involved;
 - for the date of the next test to be performed on the valve (in the case of valves that need to be periodically tested);
 - on cylinders or mobile cryogenic vessels to ensure that any tests required by national or international regulations (such as hydrostatic pressure test or equivalent for cylinders) have been conducted and are still valid;
 - ensuring that each cylinder is labelled as required.
- 14.27 A batch should be defined for filling operations.
- 14.28 Cylinders and mobile cryogenic vessels that have been returned for refilling should be prepared with care in order to minimize risk of contamination. These procedures, which should include evacuation or purging operations, should be validated.
- 14.29 There should be appropriate checks to ensure that each cylinder or mobile cryogenic vessel has been properly filled.
- 14.30 Each filled cylinder should be tested for leaks using an appropriate method prior to fitting the tamper-resistant seal or device. The test method should

not introduce any contaminant into the valve outlet and, if applicable, should be performed after any quality sample is taken.

- 14.31 After filling, cylinder valves should be fitted with covers to protect the outlets from contamination. Cryogenic vessels should be fitted with tamper-resistant devices.
- 14.32 Each cylinder or mobile cryogenic vessel should be labelled. Patient information leaflets can be made available electronically.
- 14.33 In the case of medicinal gases produced by mixing two or more different gases (in line before filling or directly into the cylinders), the mixing process should be validated to ensure that the gases are properly mixed in every cylinder and that the mixture is homogeneous.

15. Quality control

- 15.1 Each batch of medicinal gas (cylinders, mobile cryogenic vessels, tanks) should be tested in accordance with the marketing authorization, authorized specification or pharmacopoeia and a record of analysis should be maintained, for example a certificate of analysis.

Sampling

- 15.2 There should be an authorized sampling procedure with a sampling plan for testing medicinal gases.
- 15.3 In the case of a single medicinal gas:
- filled via a multicylinder manifold, the gas from at least one cylinder from each manifold filling cycle should be tested for identity, strength and purity each time the cylinders are changed on the manifold;
 - filled into cylinders one at a time, the gas from at least one cylinder of each uninterrupted filling cycle should be tested for identity, strength and purity.

Note: An example of an uninterrupted filling cycle is one shift's production using the same personnel, equipment and batch of gas to be filled.

- 15.4 In the case of a medicinal gas produced by mixing two or more gases in a cylinder from the same manifold, the gas from every cylinder should be tested for identity, strength and purity of each component.

- 15.5 For excipients, if any, testing on identity could be performed on one cylinder per manifold filling cycle (or per uninterrupted filling cycle in the case of cylinders filled one at a time). Fewer cylinders may be tested in the case of a validated automated filling system.
- 15.6 Premixed gases should follow the same principles as single gases when a continuous in-line testing of the mixture to be filled is performed. Premixed gases should follow the same principle as medicinal gases produced by mixing gases in the cylinders when there is no continuous in-line testing of the mixture to be filled.
- 15.7 The testing for water content should be performed, where required (note the requirements in the pharmacopoeia and as specified by the national regulatory authority).
- 15.8 Other sampling and testing procedures that provide at least an equivalent level of quality assurance may be justified.
- 15.9 Final testing on mobile cryogenic vessels should include a test for assay and identity on each vessel, unless otherwise authorized by the medicines regulatory authority. Testing by batches should only be carried out if it has been demonstrated that the critical attributes of the gas remaining in each vessel before refilling have been maintained.

Note: Where mobile cryogenic vessels are warm or returned from the market with residual product, the gas generated when filling the vessel is sufficient to purge the vessel adequately without any additional purging steps to remove any atmospheric contamination.

- 15.10 Cryogenic vessels retained by customers (hospital tanks or home cryogenic vessels) that are refilled in place from dedicated tankers do not need to be sampled after filling, provided that a certificate of analysis on the contents of the tanker accompanies the delivery.
- 15.11 Records of manual analysis should include at least the following:
- name of the medicinal gas;
 - batch number;
 - references to the relevant specifications and testing procedures, as approved in the marketing authorization;
 - test results and reference to any specifications (limits);
 - dates and reference numbers of testing;
 - initials of the persons who performed the testing;

- date and initials of the persons who verified the testing and the calculations, where appropriate;
- a clear statement of release or rejection (or other status decision) and the date and signature of the designated responsible person.

15.12 Records of automatic analysis should include at least the following:

- name of the medicinal gas, time and date, and the identity of the person initiating the test. Where access to the sampling and analysis system is controlled, the initials of the person initiating the test may be automatically recorded. The person initiating the test is not required to be part of the quality control department;
- batch number;
- test results, reference to the specification limits and a statement of passed or rejected;
- a clear statement of the change of status of the product being tested.

Note: For automated systems, the person initiating the testing may be the same person responsible for filling the cylinders. Formal approval of the test results may be performed by the responsible person remotely to indicate approval or rejection.

15.13 For bulk medicinal liquid oxygen tankers used for the filling of cryogenic vessels at the customer's premises, the certification and release of batches by the responsible person may be performed retrospectively within a defined time frame, provided the medicinal gas manufacturer can demonstrate that the product being supplied is suitable for patient use.

15.14 Reference and retention samples are not required, unless otherwise specified.

16. Product life cycle and continuous improvement

16.1 Manufacturers of medicinal gases should consider adopting a life cycle approach and continuous improvement. These principles should be applied in the relevant areas of the facility, equipment, instrument, utility, product and processes.

16.2 A means should be identified for continuous improvement to enable optimizing production and control whilst meeting current demands for supply and satisfying quality requirements of medicinal gases.

17. Storage and distribution

Storage

- 17.1 Precautions should be taken to prevent unauthorized persons from entering storage areas.
- 17.2 Storage areas should be under cover with sufficient capacity to allow the orderly storage of the different medicinal gases. In exceptional cases where this is not possible, as in the case of bundles of cylinders or large-sized cylinders, the gas outlet should be protected from environmental contamination.
- 17.3 Storage areas should be appropriately designed, constructed and maintained. They should be kept clean and dry and there should be sufficient space and ventilation throughout.
- 17.4 Where special storage conditions are required, these should be provided, controlled, monitored and recorded.
- 17.5 Empty cylinders should be stored separately.
- 17.6 A written cleaning programme should be available indicating the frequency of cleaning and the methods to be used to clean the storage areas.
- 17.7 There should be a written programme for pest control.
- 17.8 Broken or damaged cylinders that can no longer be used should be withdrawn from usable stock and stored separately.
- 17.9 Periodic stock reconciliation should be performed at defined intervals by comparing the actual and recorded stocks. Discrepancies should be identified and investigated. The appropriate corrective action should be taken.

Distribution

- 17.10 Filled gas cylinders and home cryogenic vessels should be handled in such a manner to ensure that they are delivered to customers in a clean and safe state.
- 17.11 Medicinal gases should be transported in accordance with the conditions stated on the labels.
- 17.12 Product, batch and container identity should be maintained at all times. All labels should remain legible.

- 17.13 Distribution records should be sufficiently detailed to allow recall when required.
- 17.14 Appropriately equipped vehicles should be suitable for the transport of medicinal gases, with sufficient space.
- 17.15 Vehicles should be kept clean and maintained.
- 17.16 Defective vehicles and equipment should not be used. These should either be labelled as such or removed from service.
- 17.17 Procedures should be in place for the operation and maintenance of all vehicles and equipment.
- 17.18 There should be written procedures, programmes and records for the cleaning of tankers and vehicles. Agents used should not have any adverse effect on product quality or be a source of contamination.
- 17.19 There should be documented, detailed procedures for the dispatch of medicinal gases. Records for the dispatch should include relevant information to allow traceability. Such records should facilitate the recall of a batch of a medicinal gas whenever necessary.
- 17.20 Tankers and cylinders should be secured to prevent unauthorized access.
- 17.21 Procedures for transport should ensure that:
- the identity of the medicinal gas is not lost
 - there is no risk of contamination of the medicinal gas
 - precautions are taken against damage and theft
 - environmental conditions are maintained, if required.
- 17.22 The appropriate signs and warnings, where required, should be visible on tankers and vehicles.

References

Note: Some parts of the text may have been adapted from other WHO GMP guidelines, as well as those published by the European Union and Pharmaceutical Inspection Co-operation Scheme. The intention is to establish a document that reflects current requirements and is harmonized with those texts. For further details on some of the topics, further reading of original guidelines is recommended.

1. WHO good manufacturing practices for active pharmaceutical ingredients. In: WHO Expert Committee on Specifications for Pharmaceutical Preparations: forty-fourth report. WHO Technical Report Series No. 957, Annex 2. Geneva: World Health Organization; 2010.
2. WHO good manufacturing practices for pharmaceutical products: main principles. In: WHO Expert Committee on Specifications for Pharmaceutical Preparations: forty-eight report. WHO Technical Report Series No. 986, Annex 2. Geneva: World Health Organization; 2014.
3. Good manufacturing practices: water for pharmaceutical use. In: WHO Expert Committee on Specifications for Pharmaceutical Preparations: fifty-fifth report. WHO Technical Report Series No. 1033, Annex 3. Geneva: World Health Organization; 2021.
4. Guideline on data integrity. In: WHO Expert Committee on Specifications for Pharmaceutical Preparations: fifty-fifth report. WHO Technical Report Series No. 1033, Annex 4. Geneva: World Health Organization; 2021.
5. WHO good practices for pharmaceutical quality control laboratories. In: WHO Expert Committee on Specifications for Pharmaceutical Preparations: forty-fourth report. WHO Technical Report Series No. 957, Annex 1. Geneva: World Health Organization; 2010.
6. Good storage and distribution practices for medical products. In: WHO Expert Committee on Specifications for Pharmaceutical Preparations: fifty-fourth report. WHO Technical Report Series No. 1025, Annex 7. Geneva: World Health Organization; 2020.
7. WHO guidelines for sampling of pharmaceutical products and related materials. In: WHO Expert Committee on Specifications for Pharmaceutical Preparations: thirty-ninth report. WHO Technical Report Series No. 929, Annex 4. Geneva: World Health Organization; 2005.
8. Guidelines on heating, ventilation and air-conditioning systems for non-sterile pharmaceutical products. In: WHO Expert Committee on Specifications for Pharmaceutical Preparations: fifty-second report. WHO Technical Report Series No. 1010, Annex 8. Geneva: World Health Organization; 2018.
9. WHO good manufacturing practices: guidelines on validation. In: WHO Expert Committee on Specifications for Pharmaceutical Preparations: fifty-third report. WHO Technical Report Series No. 1019, Annex 3. Geneva: World Health Organization; 2019.
10. WHO good practices for pharmaceutical microbiology laboratories. In: WHO Expert Committee on Specifications for Pharmaceutical Preparations: forty-fifth report. WHO Technical Report Series No. 961, Annex 2. Geneva: World Health Organization; 2011.
11. WHO guidelines on quality risk management. In: WHO Expert Committee on Specifications for Pharmaceutical Preparations: forty-seventh report. WHO Technical Report Series No. 981, Annex 2. Geneva: World Health Organization; 2013.
12. Technical supplements to model guidance for storage and transport of time- and temperature-sensitive pharmaceutical products. In: WHO Expert Committee on Specifications for Pharmaceutical Preparations: forty-ninth report. WHO Technical Report Series No. 992, Annex 5. Geneva, World Health Organization; 2015.
13. Inspection on medicinal gases. Aide-memoire PI 025-2. Geneva: Pharmaceutical Inspection Co-operation Scheme; 2007.
14. Manufacture of medicinal gases. In: EudraLex – The rules governing medicinal products in the European Union. Volume 4: Good manufacturing practice. Brussels: European Commission Enterprise and Industry Directorate-General; 2010.
15. The International Pharmacopoeia, 10th edition. Geneva: World Health Organization; 2020.

16. ISO 32:1977. Gas cylinders for medical use: marking for identification of content. International Standard ISO 32. Geneva: International Organization for Standardization; 1977.
17. ISO 7225:2005. Gas cylinders: precautionary labels. International Standard ISO 7225. Geneva: International Organization for Standardization; 2005.

Annex 6

WHO good practices for research and development facilities of pharmaceutical products

Background

In view of the need for the development of health products, including research and development for the treatment of COVID-19 therapies, the World Health Organization (WHO) Prequalification Team – Inspection Services (PQT/INS) raised the urgency for the development of life cycle-appropriate good practices text to address the manufacturing of developmental batches, pilot batches and the sequential stability data that are submitted in product applications (dossiers) for marketing authorization and the prequalification of medical products.

There is currently no other specific WHO guideline that addresses this matter. The data collected from these batches influence the following aspects of the product:

- stability
- process validation
- analytical method development and validation.

Contents

Background	251
1. Introduction	253
2. Scope	254
3. Glossary	255
4. Quality management	258
5. Quality risk management	260
6. Sanitation and hygiene	260
7. Qualification and validation	260
8. Outsourced activities	261
9. Self-inspection and quality audits	262
10. Personnel	263



11. Training	263
12. Premises	263
13. Equipment and instruments	264
14. Materials	265
15. Documentation	266
16. Processing and process design	267
17. Quality control	268
18. Stability studies	269
19. Analytical procedure development	270
20. Technology transfer	270
21. Life cycle approach	271
22. Cleaning procedure development, cleaning verification and cleaning validation	271
References	272

1. Introduction

- 1.1 With an ever-increasing awareness of the risks in pharmaceutical production and control and the life cycle approaches being followed, greater emphasis is being placed on ensuring that the research and development of products are appropriately controlled and documented.
- 1.2 Consequently, it is necessary that manufacturers of pharmaceutical products are able to submit all relevant data and information related to their development, including the facilities used, the experimental designs employed in the validation of manufacturing processes, and quality control procedures, to the regulators, where required, for review. This is to ensure that the facilities, quality systems, data and information meet the appropriate standards and applicable good practices.
- 1.3 This document intends to provide guidance on good practices to research and development facilities. It further aims to ensure that the correct systems are followed, ensuring appropriateness, reliability and the quality of products, processes, procedures and data. This further helps to ensure that products meet the requirements for safety, efficacy and quality that they purport to possess.
- 1.4 In addition to product development, other activities – including the production of pilot-scale batches, process validation, cleaning procedure development, cleaning validation studies, and stability studies – are often undertaken in such facilities.
- 1.5 The World Health Organization (WHO) document *WHO good manufacturing practices for investigational products (1)* specifically addresses the requirements and recommendations for products used in clinical trials. Other WHO guidelines address specific requirements and recommendations, including data integrity, stability testing, analytical method validation, cleaning validation and technology transfer (see references and further reading sections at end of document).
- 1.6 This document should be read in conjunction with other WHO guidelines on good manufacturing practices (GMP), where appropriate and where applicable, as referenced in the relevant documents (2–14). Other documents of interest are listed under the section on further reading following the reference list.

2. Scope

- 2.1 This guideline is specifically applicable to research and development facilities of pharmaceutical products, procedures, processes and data that are intended for transfer and submission for approval in marketing authorization applications, process validation, technology transfer-related activities (15), validation (7), quality control laboratory activities such as stability testing and development (16), and validation of cleaning procedures (see Figure 1 and section 4 below).
- 2.2 The main focus of this document is to provide guidance on good practices in the production and control of preclinical and not-for-human-use batches, manufactured in pharmaceutical formulation and development facilities, where these are directly supporting (for example) shelf-life claims, animal studies or validation activities. The principles described in this document may be applied in facilities where other products, such as biopharmaceutical products, vaccines and medical devices, are manufactured.
- 2.3 This guide excludes whole cells, whole blood and plasma, blood and plasma derivatives (plasma fractionation), medicinal gases, radiopharmaceuticals and gene therapy products.
- 2.4 The sections below are to be considered general guidance and may be adapted to meet individual needs. The effectiveness of alternative approaches, however, should be demonstrated.
- 2.5 In this guide, the term “should” indicates recommendations that are expected to apply unless they are shown to be not applicable or can be replaced by an alternative demonstrated to be acceptable.
- 2.6 This guide, as a whole, does not cover safety aspects for the personnel engaged in the research and development or the aspects of protection of the environment. These controls are inherent responsibilities of the manufacturer and are governed by national laws.
- 2.7 This guide is not intended to define registration requirements or modify pharmacopoeial requirements or other guideline recommendations. For details on process development, it is recommended that other guidelines, such as those published by the International Council for Harmonisation of Technical Requirements for Pharmaceuticals for Human Use (ICH), be read in conjunction with this document.
- 2.8 This guide does not affect the ability of the responsible regulatory agency to establish specific registration or filing requirements. All commitments

in registration and filing documents must be met. This document provides information to consider for a risk- and science-based approach in the research and development of pharmaceutical products.

- 2.9 Due to the nature of development work, and an increasing expectation for compliance with standards in manufacture, the guidance in this document would normally be applied based on risk assessment, in an increasing manner, from development to commercial batch manufacturing. The application of good practices in research and development should increase as the process proceeds from early development work to the final steps of development and formulation, stability testing, process validation and cleaning validation.

Fig. 1

Application of this guideline

Early research – research – development/formulation – registration batches



- ^a The principles described in this guideline are applied, based on risk management principles, in an increased manner from early research to development to registration batches.

3. Glossary

The definitions given below apply to the terms used in this guideline. They have been aligned as much as possible with the terminology in related WHO guidelines and good practices and included in the WHO *Quality Assurance of Medicines Terminology Database: list of terms and related guideline*,¹ but may have different meanings in other contexts.

batch (or lot). A defined quantity of starting material, packaging material or product processed in a single process or series of processes so that it is expected to be homogeneous. It may sometimes be necessary to divide a batch into a number of sub-batches that are later brought together to form a final homogeneous batch.

¹ https://www.who.int/docs/default-source/medicines/norms-and-standards/guidelines/mqa-terminology-sept-2020.pdf?sfvrsn=48461cfc_5.

In the case of terminal sterilization, the batch size is determined by the capacity of the autoclave. In continuous manufacture, the batch must correspond to a defined fraction of the production, characterized by its intended homogeneity. The batch size can be defined either as a fixed quantity or as the amount produced in a fixed time interval.

batch records. All documents associated with the manufacture of a batch of bulk product or finished product. They provide a history of each batch of product and of all circumstances pertinent to the quality of the final product.

bulk product. Any product that has completed all processing stages, usually not including final packaging and labelling.

calibration. The set of operations that establish, under specified conditions, the relationship between values indicated by an instrument or system for measuring (especially weighing), recording and controlling, or the values represented by a material measure, and the corresponding known values of a reference standard. Limits for acceptance of the results of measuring should be established.

cleanability. The factors that impact the ability to remove a residue from surfaces, including material of construction, the solubility of the material in different agents and the matrix of the material being cleaned.

cleaning verification. The act of demonstrating that cleaning was done to an acceptable level, for example, between two batches.

contamination. The undesired introduction of impurities of a chemical or microbiological nature, or of foreign matter, into or onto a starting material or intermediate during production, sampling, packaging or repackaging, storage or transport.

finished product. A finished dosage form that has undergone all stages of manufacture, including packaging in its final container and labelling.

in-process control. Checks performed during production in order to monitor and, if necessary, adjust the process to ensure that the product conforms to its specifications. The control of the environment or equipment may also be regarded as a part of in-process control.

intermediate product. A partly processed product that must undergo further manufacturing steps before it becomes a bulk product.

knowledge management. Systematic approach to acquiring, analysing, storing and disseminating information related to products, manufacturing processes and components.

manufacture/manufacturing. Includes all operations of receipt of materials, production, packaging, repackaging, labelling, relabelling, quality control, release, storage, distribution and related controls.

manufacturer. A company that carries out operations such as production, packaging, repackaging, labelling and relabelling of pharmaceuticals.

marketing authorization (product licence, registration certificate). A legal document issued by the competent medicines regulatory authority that establishes the detailed composition and formulation of the product and the pharmacopoeial or other recognized specifications of its ingredients and of the final product itself, and includes details of packaging, labelling and shelf-life.

master formula. A document or set of documents specifying the starting materials with their quantities and the packaging materials, together with a description of the procedures and precautions required to produce a specified quantity of a finished product, as well as the processing instructions, including the in-process controls.

master record. A document or set of documents that serves as a basis for the batch documentation (blank batch record).

packaging. All operations, including filling and labelling, that a bulk product has to undergo in order to become a finished product. The filling of a sterile product under aseptic conditions, or a product intended to be terminally sterilized, would not normally be regarded as part of packaging.

packaging material. Any material, including printed material, employed in the packaging of a pharmaceutical, but excluding any outer packaging used for transportation or shipment. Packaging materials are referred to as primary or secondary according to whether or not they are intended to be in direct contact with the product.

pharmaceutical product. Any material or product intended for human or veterinary use presented in its finished dosage form or as a starting material for use in such a dosage form that is subject to control by pharmaceutical legislation in the exporting state and/or the importing state. (Note: In this guidance, the term pharmaceutical product may include products for preclinical use.)

production. All operations involved in the preparation of a pharmaceutical product, from receipt of materials through processing, packaging and repackaging, labelling and relabelling, to completion of the finished product.

qualification. Documented evidence that premises, systems or equipment are able to achieve the predetermined specifications, are properly installed, and/or work correctly, and lead to the expected results.

quality audit. An examination and assessment of all or part of a quality system with the specific purpose of improving it. A quality audit is usually conducted by outside or independent specialists or a team designated by the management for this purpose. Such audits may also be extended to suppliers and contractors.

quality risk management. A systematic process for the assessment, control, communication and review of risks.

specification. A list of detailed requirements with which the products or materials used or obtained during manufacture have to conform. They serve as a basis for quality evaluation.

standard operating procedure. An authorized written procedure giving instructions for performing operations not necessarily specific to a given product or material (for example, equipment operation, maintenance and cleaning; validation; cleaning of premises and environmental control; sampling and inspection). Certain standard operating procedures may be used to supplement product-specific master and batch production documentation.

starting material. Any substance of a defined quality used in the production of a pharmaceutical product, but excluding packaging materials.

validation. The action of proving, in accordance with the principles of GMP, that any procedure, process, equipment, material, activity or system actually leads to the expected results.

4. Quality management

4.1 There should be a quality management system encompassing adequate resources, a written organizational structure and procedures to follow.

4.2 All parts of the quality management system should be adequately resourced and maintained, including with sufficient competent personnel, suitable premises, equipment and facilities. The necessary resources should include:

- a sufficient number of appropriately qualified, trained personnel
- adequate premises and space
- suitable equipment and services
- appropriate materials, containers and labels
- suitable storage and transport.

4.3 Roles, responsibilities and authorities should be defined, communicated and implemented.

- 4.4 The quality system should facilitate innovation and continual improvement and strengthen the link between pharmaceutical development and manufacturing activities.
- 4.5 Initial research, as well as development activities, should be defined and documented. Development activities, including initial research, should be adequately documented. Controls should be commensurate with the stage of product development – that is, for testing options or at a final stage for further use where the guideline on *WHO good manufacturing practices for investigational products* applies (1).
- 4.6 The quality system should ensure, as applicable and according to the stage of research and development, that:
- managerial responsibilities are clearly specified in job descriptions;
 - personnel are trained;
 - instructions and procedures are written in clear and unambiguous language, and followed;
 - procedures are correctly carried out;
 - records are made (manually or by recording instruments) during production and testing;
 - records are maintained;
 - there is a system for quality risk management that is applied, as appropriate;
 - arrangements are made for the manufacture, supply and use of the correct starting and packaging materials;
 - all necessary controls on starting materials, intermediate products, bulk products and other in-process controls are carried out;
 - calibrations and validations are carried out, where appropriate;
 - the product and process knowledge is managed;
 - products are designed and developed in accordance with applicable good practices, as appropriate;
 - development procedures are documented;
 - cleaning procedures are developed, verified and validated, where appropriate;
 - stability testing is done following written procedures and protocols;
 - data meet ALCOA+ (attributable, legible, contemporaneous, original and accurate) requirements, where applicable.

- 4.7 There should be a periodic management review with the involvement of senior management.

5. Quality risk management

- 5.1 A system of quality risk management should be implemented. The system should ensure that risks are identified based on scientific knowledge and experience. The appropriate controls should be identified and implemented to mitigate risks.
- 5.2 The level of effort, formality and documentation of the quality risk management process is commensurate with the level of risk and the stage from research to development, to commercial batch manufacturing and control (see Figure 1).
- 5.3 Systems should be in place to manage and minimize the risks inherent in research and development.

6. Sanitation and hygiene

- 6.1 Procedures should be implemented to maintain sanitation and hygiene. The scope of sanitation and hygiene covers personnel, premises, equipment and apparatus, production materials and containers, and products for cleaning and disinfection.
- 6.2 Potential sources of contamination should be identified and controlled.

7. Qualification and validation

- 7.1 Where qualification and validation are performed, the scope and extent should be appropriate using a risk-based approach.
- 7.2 The qualification and validation policy and approach should be defined and documented, for example, in a validation master plan.
- 7.3 Where qualification and validation are carried out, the responsibility for performing validation should be clearly defined.
- 7.4 Where process validation, cleaning validation and analytical procedure validation are done as a part of development, procedures and protocols should be followed. Reports should be available and retained.

8. Outsourced activities

- 8.1 Outsourced activities should be correctly defined, agreed and controlled through a written agreement.
- 8.2 All responsibilities and arrangements for activities, such as quality control (QC) testing and technology transfer, should be clearly described.

The contract giver

- 8.3 The contract giver is responsible for assessing the suitability and competence of the contract acceptor to successfully carry out the work or tests required and for approval of the contract activities.
- 8.4 The contract giver should provide the contract acceptor with all the information necessary to carry out the contracted operations correctly.
- 8.5 The contract giver should ensure that the contract acceptor is fully aware of any hazards associated with the product, work or tests.
- 8.6 The contract giver should review and assess relevant records and results related to the outsourced activities.
- 8.7 The contract giver is responsible for ensuring that the contract acceptor understands that its activities may be subject to inspection by the competent authorities.

The contract acceptor

- 8.8 The contract acceptor must have adequate premises, equipment, knowledge, experience, and competent, trained personnel to satisfactorily carry out the work ordered by the contract giver.
- 8.9 The contract acceptor should not pass to a third party any of the work entrusted under the contract without the contract giver's prior evaluation and approval of the arrangements.
- 8.10 The contract acceptor should agree to a period of time for retention of documents and data prior to archival or returning to the contract giver.

The agreement

- 8.11 The technical aspects of the agreement should be drawn up by competent persons suitably knowledgeable in the field of law, research, development and good practices.

- 8.12 The agreement should define the roles and responsibilities of all parties.
- 8.13 The agreement should permit the contract giver to audit the facilities and activities of the contract acceptor.

9. Self-inspection and quality audits

- 9.1 There should be a written self-inspection programme.
- 9.2 Self-inspection should be performed routinely and may, in addition, be performed on special occasions.
- 9.3 The team responsible for self-inspection should consist of personnel with the appropriate knowledge and experience, free from bias.
- 9.4 Self-inspection should cover at least the following items, where appropriate:
- personnel
 - premises, including personnel facilities
 - maintenance of buildings and equipment
 - storage of starting materials and finished products
 - equipment
 - production and in-process controls
 - QC
 - documentation
 - data and data integrity
 - sanitation and hygiene
 - qualification and validation
 - calibration of instruments or measurement systems
 - control of labels
 - results of previous self-inspections and any corrective steps taken.
- 9.5 The outcome of the self-inspection should be documented. Corrective actions and preventive actions should be identified and implemented within a defined timeline. There should be an effective follow-up programme.
- 9.6 Self-inspections may be supplemented by independent quality audits.

10. Personnel

- 10.1 Individual responsibilities should be clearly defined and understood by the persons concerned and recorded as written descriptions.
- 10.2 All personnel should be aware of the principles of this guideline and other applicable good practices (GxP).
- 10.3 Steps should be taken to prevent unauthorized people from entering storage, production and QC areas.
- 10.4 Smoking, eating, drinking, chewing and keeping plants, food, drink, smoking material and personal medicines should not be permitted in any area where they might adversely influence product quality.
- 10.5 The appropriate protective garments should be worn, based on operation performed and risk.
- 10.6 Personnel who are ill should not engage in the manufacture of pharmaceutical products.

11. Training

- 11.1 Training should be provided in accordance with a written programme that covers topics such as the theory and practice of GMP and the duties assigned. The appropriate task-related training should be further provided based on technical requirements and activities undertaken.
- 11.2 The effectiveness of training should be assessed.
- 11.3 Training and assessment records should be kept.
- 11.4 Where appropriate, specific training should be given on the handling and segregation of highly active, toxic, infectious or sensitizing materials and the need for separate, dedicated facilities where these are required.

12. Premises

- 12.1 Premises should be located, designed, constructed, adapted and maintained to suit the operations to be carried out.
- 12.2 The layout and design should aim to minimize the risk of errors and permit effective cleaning and maintenance in order to avoid build-up of dust or dirt and, in general, any adverse effect on the products and activities.

- 12.3 The premises should be cleaned according to detailed procedures. Records should be maintained.
- 12.4 The electrical supply, lighting, temperature, humidity and ventilation should be appropriate.
- 12.5 Toilets and rest and refreshment rooms should be separate from production and control areas.
- 12.6 Storage areas should be of sufficient capacity, with proper separation and segregation of materials.
- 12.7 Storage areas should be clean and dry and should be designed or adapted to ensure that the required storage conditions are maintained. Conditions should be controlled, monitored and recorded, where appropriate.
- 12.8 Certain materials, such as highly active radioactive materials and narcotics, should be stored in safe and secure areas.
- 12.9 Materials identified for testing should be sampled and analysed.
- 12.10 The stages in production, including weighing, compounding, and packaging, should be done in a manner that prevents contamination and mix-ups.
- 12.11 QC areas should be designed to suit the operations to be carried out in them. There should be sufficient space, instruments, and equipment, and the appropriate reference materials, solvents and reagents.
- 12.12 Poisons, pesticides and hazardous materials should not be stored or used in product manufacturing areas.

13. Equipment and instruments

- 13.1 The equipment and instruments should be located, designed, constructed, adapted and maintained to suit the operations to be carried out. They should allow for effective cleaning and maintenance in order to avoid a build-up of dust or dirt.
- 13.2 Pipework, instruments and devices should be adequately marked.
- 13.3 Measuring equipment should be available for production and control operations and, where necessary, should be calibrated, verified and serviced on a scheduled basis. Records should be maintained.

- 13.4 The equipment and instruments should be thoroughly cleaned on a scheduled basis.
- 13.5 Defective equipment and instruments should be removed from operational areas or be clearly labelled as defective in order to prevent use.

14. Materials

- 14.1 Materials should be purchased from suitable suppliers.
- 14.2 Where so identified, materials should be quarantined immediately after receipt, sampled and tested.
- 14.3 Materials should be used within their shelf-life.
- 14.4 Materials should be stored under the appropriate conditions, as specified on their labels, and in an orderly fashion to permit segregation.
- 14.5 The dispensing of materials for the production of a batch should be recorded. Materials should be accurately weighed or measured into clean and properly labelled containers.
- 14.6 No materials used for operations, such as cleaning, the lubrication of equipment or pest control, should come into direct contact with the product. Where possible, such materials should be of a suitable grade (for example, food grade) to minimize health risks.
- 14.7 All materials, including water, should be suitable for its intended use.
- 14.8 Packaging and printed materials should be stored in secure conditions so as to exclude the possibility of unauthorized access.
- 14.9 Intermediate and bulk products should be kept under appropriate conditions.
- 14.10 Finished products should be stored under suitable conditions and appropriately segregated.
- 14.11 Rejected materials and products should be clearly marked as such. They should be handled in an appropriate and timely manner. Whatever action is taken should be approved by authorized personnel and recorded.
- 14.12 Toxic substances and flammable materials should be stored in suitably designed, separate, enclosed containers, and as required by national legislation.

- 14.13 All waste materials should be stored in a safe manner and disposed of at regular intervals to avoid accumulation.

15. Documentation

- 15.1 Documentation includes procedures for materials and methods of production and control. The design and use of documents depend upon the research and development facility.
- 15.2 Documents should be designed, prepared, reviewed and authorized for use.
- 15.3 Standard operating procedures should be reviewed periodically and kept up to date. Superseded documents should be retained for a defined period of time.
- 15.4 Entries of data and information should be clear and legible and meet ALCOA+ principles, as applicable.
- 15.5 GxP data (including records for storage) may be recorded by electronic data-processing systems or by photographic or other reliable means. Batch production and control records should be protected throughout the defined period of retention.
- 15.6 Labels should be clear and unambiguous, and in the company's agreed format.
- 15.7 There should be appropriately authorized and dated specifications, including tests on identity, purity and quality, for starting materials and for finished products, as appropriate.
- 15.8 Pharmacopoeias, reference standards, reference spectra and other reference materials should be available, where applicable.
- 15.9 Specifications should contain appropriate information, such as the designated name, internal code reference, and qualitative and quantitative requirements, with acceptance criteria. Other data may be added to the specification.
- 15.10 The packaging material should be examined for compliance with the specification, as appropriate.
- 15.11 Specifications for intermediate and bulk products should be available where the need has been identified, as appropriate.

- 15.12 Specifications for finished products should be available and include the required information, where available.
- 15.13 A master formula or batch recipe, containing the relevant information, should be available for the product and batch size.
- 15.14 Packaging instructions should exist for the products to be packed.
- 15.15 A batch processing record should be kept for each batch processed.
- 15.16 During processing, detailed information should be recorded at the time each action is taken. Upon completion, the record should be dated and signed by the person responsible in accordance with data integrity expectations.
- 15.17 A batch packaging record should be kept for each batch packed.
- 15.18 Standard operating procedures and corresponding records, where required, should be available. These include:
- equipment assembly and cleaning
 - personnel training, clothing and hygiene
 - maintenance
 - sampling
 - analytical apparatus and instrument calibration
 - testing
 - rejection
 - pest control.
- 15.19 Before any processing operation is started, steps should be taken to ensure that the work area and equipment are clean and free from any starting materials, products, product residues and labels or documents not required for the current operation.

16. Processing and process design

Processing

Note: For more details on specific aspects relating to process development, see ICH guidelines Q8 and Q11 (17, 18).

- 16.1 The selection of the starting materials and manufacturing process should be carefully considered in order to ensure that the intended product will meet the intended standards of safety, efficacy and quality in a consistent manner.

- 16.2 Knowledge management and risk assessment principles should be applied. Quality attributes, critical quality attributes, process parameters and critical process parameters should be defined and documented once sufficient data are available.
- 16.3 The design of experiments should cover identified variables.

Process design

Note: For details on process validation, see WHO Technical Report Series No. 1019, Annex 3, Appendix 7, 2019 (10) as well as European Union and United States Food and Drug Administration guidelines (19, 20).

- 16.4 Process design – often referred to historically as “prospective validation” – is usually initiated by research and development facilities.
- 16.5 Process design should normally cover the design of experiments, process development, the manufacture of products for use in clinical trials, pilot-scale batches and technology transfer.
- 16.6 Process design should be verified during product development. Process design should cover such aspects as the selection of materials; consideration for expected impurities; expected production variation; selection of production technology or process and qualification of the unitary processes that form the manufacturing process as a whole; selection of in-process controls; tests; inspection; and its suitability for the control strategy.
- 16.7 Where the validation data are intended to be used in applications for marketing authorization, all batch data, results and related information should be clear, detailed and in compliance with ALCOA+.

17. Quality control

- 17.1 There should be adequate resources available to ensure that all the QC arrangements are effectively and reliably carried out.
- 17.2 Activities and responsibilities of the QC unit include:
- sampling and testing (for example, starting materials, packaging materials, intermediate products, bulk products and finished products);
 - performing the necessary qualification and validation;
 - evaluating, maintaining and storing reference materials;

- ensuring that the stability programme and testing are carried out;
 - conducting environmental monitoring.
- 17.3 The appropriate records should be kept, demonstrating that all the required activities were performed.
- 17.4 Sufficient samples of materials and products should be retained for a defined period of time.
- 17.5 The appropriate reference standards (official, secondary or working standards) should be used. Standards should be stored in an appropriate way.
- 17.6 Whenever official reference standards exist, these should preferably be used.
- 17.7 Where secondary and working standards are established and used, these should be tested at regular intervals to ensure that they are fit for their intended use.
- 17.8 Reference standards should be appropriately labelled with at least the following information:
- name of the material
 - batch or lot number and control number
 - date of qualification
 - requalification date
 - potency
 - storage conditions.

18. Stability studies

Note: See guideline on stability testing of active pharmaceutical ingredients and finished pharmaceutical products, WHO Technical Report Series No. 1010, Annex 10, 2018 (11).

- 18.1 Where stability determination is initiated by research and development organizations, a written programme should be developed and implemented to include such elements as:
- a complete description of the product involved in the study;
 - the complete set of testing procedures, parameters and limits;
 - attributes such as potency or assay, degradation products and physical characteristics;

- evidence that these tests indicate stability;
- the testing schedule for each product;
- provision for special storage conditions;
- provision for adequate sample retention.

- 18.2 Sampling should be done in accordance with written procedures.
- 18.3 Sample preparation and testing procedures should be detailed and followed. Any deviations from the procedures should be clearly documented.
- 18.4 The results and data generated should be documented and should include the evaluation and the conclusions of the study.
- 18.5 Where stability data are intended to be used in applications for marketing authorizations, all batch data, results and related information should be clear, detailed and in compliance with ALCOA+.
- 18.6 Records should be maintained for a defined period of time.

19. Analytical procedure development

- 19.1 Analytical procedures developed by research and development organizations should be appropriately documented in sufficient detail to facilitate their successful transfer, when required.
- 19.2 Analytical procedures should be appropriately validated, where required, as fit for purpose.

Note: For details on analytical procedure validation, see WHO Technical Report Series No. 1019, Annex 3, Appendix 4, 2019 (12).

20. Technology transfer

Note: For details on technology transfer, see WHO Technical Report Series No. 1044, Annex 4, 2022 (15).

- 20.1 Development work, including programmes, procedures, protocols, specifications, process design and validation from research and development facilities, may be transferred to commercial manufacturing and QC sites.
- 20.2 Data and information relating to equipment, instruments, manufacturing and testing should be at an appropriate level of detail, traceable and available.

- 20.3 Authorized procedures should be followed when transferring technology from research and development organizations to commercial manufacturing and QC facilities.

21. Life cycle approach

- 21.1 Industry should implement policies and procedures that will encourage science-based and risk-based approaches in product research and development.
- 21.2 Continual improvement should be encouraged across the entire product life cycle.
- 21.3 Knowledge gained from the commercial manufacturing of a product, as well as knowledge gained from other products, can be used to further improve process understanding and process performance.
- 21.4 New technologies and the review and interpretation of statistical evaluation of results from process design, validation and other processes, as well as other applicable data and information, should be considered in order to encourage continual improvement during the process development stage of the life cycle of the product.
- 21.5 Where appropriate, these should be shared and transferred to commercial manufacturing facilities.

22. Cleaning procedure development, cleaning verification and cleaning validation

Note: For details on cleaning validation, see WHO Technical Report Series No. 1019, Annex 3, Appendix 3, 2019, and the WHO points to consider when including health-based exposure limits (HBELs) in cleaning validation, WHO Technical Report Series No. 1033, Annex 2, 2021 (13, 14).

- 22.1 Research and development facilities may be involved in the development and validation of cleaning procedures. quality risk management principles should be applied in cleaning procedure development and cleaning validation.
- 22.2 The development of cleaning procedures should include cleanability.
- 22.3 Where preparatory work for cleaning validation is done in research and development facilities with a view to technology transfer, consideration should be given to HBELs in the approach.

- 22.4 The sampling of procedures should include swab samples and rinse samples, where appropriate. Maximum safe residue, maximum safe surface residue and visible residue limits should be considered in the cleaning validation approach.
- 22.5 The development of the analytical procedures to be used in the testing for residues should be appropriately documented. The procedures should be validated.
- 22.6 The procedures for sampling and testing, and the results obtained, should meet ALCOA+ principles. The data and information should be retained over the life cycle of the product.
- 22.7 Procedures and protocols should be followed for the technology transfer to commercial manufacturing sites.
- 22.8 Records should be maintained.

References

1. WHO good manufacturing practices for investigational pharmaceutical products. In: WHO Expert Committee on Specifications for Pharmaceutical Preparations: fifty-sixth report. WHO Technical Report Series No. 1044, Annex 7. Geneva: World Health Organization; 2022.
2. WHO good manufacturing practices for active pharmaceutical ingredients. In: WHO Expert Committee on Specifications for Pharmaceutical Preparations: forty-fourth report. WHO Technical Report Series No. 957, Annex 2. Geneva: World Health Organization; 2010.
3. WHO good manufacturing practices for pharmaceutical products: main principles. In: WHO Expert Committee on Specifications for Pharmaceutical Preparations: forty-eighth report. WHO Technical Report Series No. 986, Annex 2. Geneva: World Health Organization; 2014.
4. Good manufacturing practices: water for pharmaceutical use. In: WHO Expert Committee on Specifications for Pharmaceutical Preparations: fifty-fifth report. WHO Technical Report Series No. 1033, Annex 3. Geneva: World Health Organization; 2021.
5. WHO guidelines for sampling of pharmaceutical products and related materials. In: WHO Expert Committee on Specifications for Pharmaceutical Preparations: thirty-ninth report. WHO Technical Report Series No. 929, Annex 4. Geneva: World Health Organization; 2005.
6. Guidelines on heating, ventilation and air-conditioning systems for non-sterile pharmaceutical products. Part 2: interpretation of guidelines. In: WHO Expert Committee on Specifications for Pharmaceutical Preparations: fifty-third report. WHO Technical Report Series No. 1019, Annex 2. Geneva: World Health Organization; 2019.
7. Good manufacturing practices: guidelines on validation. In: WHO Expert Committee on Specifications for Pharmaceutical Preparations: fifty-third report. WHO Technical Report Series No. 1019, Annex 3. Geneva: World Health Organization; 2019.

8. WHO good manufacturing practices for pharmaceutical products containing hazardous substances. In: WHO Expert Committee on Specifications for Pharmaceutical Preparations: forty-fourth report. WHO Technical Report Series No. 957, Annex 3. Geneva: World Health Organization; 2010.
9. WHO good manufacturing practices for sterile pharmaceutical products. In: WHO Expert Committee on Specifications for Pharmaceutical Preparations: forty-fifth report. WHO Technical Report Series No. 961, Annex 6. Geneva: World Health Organization; 2011.
10. Guidelines on good manufacturing practices: validation. Appendix 7: Non-sterile process validation. In: WHO Expert Committee on Specifications for Pharmaceutical Preparations: fifty-third report. WHO Technical Report Series No. 1019, Annex 3. Geneva: World Health Organization; 2019.
11. Stability testing of active pharmaceutical ingredients and finished pharmaceutical products. In: WHO Expert Committee on Specifications for Pharmaceutical Preparations: fifty-second report. WHO Technical Report Series No. 1010, Annex 10. Geneva: World Health Organization; 2018.
12. Good manufacturing practices: guidelines on validation. Appendix 4: Analytical procedure validation. In: WHO Expert Committee on Specifications for Pharmaceutical Preparations: fifty-third report. WHO Technical Report Series No. 1019, Annex 3. Geneva: World Health Organization; 2019.
13. Good manufacturing practices: guidelines on validation. Appendix 3: Cleaning validation. In: WHO Expert Committee on Specifications for Pharmaceutical Preparations: fifty-third report. WHO Technical Report Series No. 1019, Annex 3. Geneva: World Health Organization; 2019.
14. Points to consider when including health-based exposure limits (HBELs) in cleaning validation. In: WHO Expert Committee on Specifications for Pharmaceutical Preparations: fifty-fifth report. WHO Technical Report Series No. 1033, Annex 2. Geneva: World Health Organization; 2021.
15. WHO guidelines on technology transfer in pharmaceutical manufacturing. In: WHO Expert Committee on Specifications for Pharmaceutical Preparations: fifty-sixth report. WHO Technical Report Series No. 1044, Annex 4. Geneva: World Health Organization; 2022.
16. WHO good practices for pharmaceutical quality control laboratories. In: WHO Expert Committee on Specifications for Pharmaceutical Preparations: forty-fourth report. WHO Technical Report Series No. 957, Annex 1. Geneva: World Health Organization; 2010.
17. Pharmaceutical development. ICH harmonised guideline Q8(R2), current step 4 version, August 2009. International Conference on Harmonisation of Technical Requirements for Registration of Pharmaceuticals for Human Use; 2009.
18. Development and manufacture of drug substances. ICH harmonised guideline Q11, current step 4 version, May 2012. International Conference on Harmonisation of Technical Requirements for Registration of Pharmaceuticals for Human Use; 2012.
19. Process validation for finished products: information and data to be provided in regulatory submissions. EMA/CHMP/CVMP/QWP/BWP/70278/2012-Rev1,Corr.1. European Medicines Agency: Committee for Medicinal Products for Human Use (CHMP) and Committee for Medicinal Products for Veterinary Use (CVMP); 2016.
20. Guidance for industry. Process validation: general principles and practices. U.S. Department of Health and Human Services: Food and Drug Administration; 2011.

Further reading: WHO guidance

- General guidelines for the establishment, maintenance and distribution of chemical reference substances. In: WHO Expert Committee on Specifications for Pharmaceutical Preparations: forty-first report. WHO Technical Report Series No. 943, Annex 3. Geneva: World Health Organization; 2007.
- Model guidance for the storage and transport of time- and temperature-sensitive pharmaceutical products. In: WHO Expert Committee on Specifications for Pharmaceutical Preparations: forty-fifth report. WHO Technical Report Series No. 961, Annex 9. Geneva: World Health Organization; 2011.
- WHO good practices for pharmaceutical microbiology laboratories. In: WHO Expert Committee on Specifications for Pharmaceutical Preparations: forty-fifth report. WHO Technical Report Series No. 961, Annex 2. Geneva: World Health Organization; 2011.
- WHO guidelines for drafting a site master file. In: WHO Expert Committee on Specifications for Pharmaceutical Preparations: forty-fifth report. WHO Technical Report Series No. 961, Annex 14. Geneva: World Health Organization; 2011.
- WHO guidelines on quality risk management. In: WHO Expert Committee on Specifications for Pharmaceutical Preparations: forty-seventh report. WHO Technical Report Series No. 981, Annex 2. Geneva: World Health Organization; 2013.
- WHO guidelines on variations to a prequalified product. In: WHO Expert Committee on Specifications for Pharmaceutical Preparations: forty-seventh report. WHO Technical Report Series No. 981, Annex 3. Geneva: World Health Organization; 2013.
- General guidance on hold-time studies. In: WHO Expert Committee on Specifications for Pharmaceutical Preparations: forty-ninth report. WHO Technical Report Series No. 992, Annex 4. Geneva: World Health Organization; 2015.
- Technical supplements to model guidance for storage and transport of time- and temperature-sensitive pharmaceutical products. In: WHO Expert Committee on Specifications for Pharmaceutical Preparations: forty-ninth report. WHO Technical Report Series No. 992, Annex 5. Geneva: World Health Organization; 2015.
- Recommendations for quality requirements when plant-derived artemisinin is used as a starting material in the production of antimalarial active pharmaceutical ingredients. In: WHO Expert Committee on Specifications for Pharmaceutical Preparations: forty-ninth report. WHO Technical Report Series No. 992, Annex 6. Geneva: World Health Organization; 2015.
- WHO general guidance on variations to multisource pharmaceutical products. In: WHO Expert Committee on Specifications for Pharmaceutical Preparations: fiftieth report. WHO Technical Report Series No. 996, section 11. Geneva: World Health Organization; 2016.
- Guidance on good data and record management practices. In: WHO Expert Committee on Specifications for Pharmaceutical Preparations: fiftieth report. WHO Technical Report Series No. 996, Annex 5. Geneva: World Health Organization; 2016.
- WHO good manufacturing practices: guidelines on validation. Appendix 5: Validation of computerized systems. In: WHO Expert Committee on Specifications for Pharmaceutical Preparations: fifty-third report. WHO Technical Report Series No. 1019, Annex 3. Geneva: World Health Organization; 2019.

Further reading: other guidance

- Quality risk management. ICH harmonised guideline Q9, current step 4 version, November 2005. International Conference on Harmonisation of Technical Requirements for Registration of Pharmaceuticals for Human Use; 2005.
- Pharmaceutical quality system. ICH harmonised guideline Q10, current step 4 version, June 2008. International Conference on Harmonisation of Technical Requirements for Registration of Pharmaceuticals for Human Use; 2008.
- Good practice guide: technology transfer, third edition. International Society for Pharmaceutical Engineering; 2018.

Annex 7

WHO good manufacturing practices for investigational products

Background

In view of an old publication date, and the recent need for new guidelines arising from inspections carried out for COVID-19 therapeutics, the World Health Organization (WHO) Prequalification Team – Inspection Services (PQT/INS) raised the urgency for a revision of the WHO *Good manufacturing practices: supplementary guidelines for the manufacture of investigational pharmaceutical products for clinical trials in humans (1)*. The fifty-fifth Expert Committee on Specifications for Pharmaceutical Preparations concurred with this proposal.

The objective of this update is to bring the guideline in line with current expectations and trends in good practices and to harmonize the text with the principles of other related international guidelines.

Contents

Background	277
1. Introduction	279
2. Scope	280
3. Glossary	280
4. Quality management	283
5. Quality risk management	284
6. Personnel	284
7. Documentation	285
7.1 Specifications	286
7.2 Order	286
7.3 Product specification file	287
7.4 Manufacturing formulae and processing instructions	287
7.5 Packaging instructions	288
7.6 Labelling instructions	288
7.7 Batch manufacturing, packaging and testing records	290
7.8 Coding (or randomization) systems	290
8. Premises	290



9. Equipment and utilities	291
10. Materials	291
10.1 Starting and packaging materials	291
10.2 Chemical and biological reference standards for analytical purposes	292
10.3 Principles applicable to reference products for clinical trials	292
11. Production	292
11.1 Manufacturing operations	293
11.2 Packaging and labelling	293
11.3 Blinding operations	293
12. Quality unit (including quality control)	294
13. Qualification and validation	295
14. Complaints	296
15. Recalls	296
16. Returns	297
17. Shipping	297
18. Destruction	298
References	298

1. Introduction

- 1.1 Investigational products are used for testing purposes; as a reference in clinical trials and field trials; as a placebo; for an unauthorized indication; or to gain further information about the authorized form.
- 1.2 In some cases, marketed products that have been repackaged or modified in some way are used for investigational purposes.
- 1.3 The legal status of investigational products varies from country to country.
- 1.4 These products are sometimes not covered by legal and regulatory provisions in the areas of good practices and inspection. In such circumstances, risks related to investigational products are increased by lack of adherence to good manufacturing practices (GMP), risk of contamination and cross-contamination, and shortcomings in clinical trial designs, blinding and randomization. In addition, there are instances where there is incomplete knowledge of the potency and safety of the investigational product.
- 1.5 There are further risks associated with the production, validation, testing, control, shipping, storage and use of investigational products.
- 1.6 To minimize risk, to ensure the safety of the subjects participating in clinical trials, and to ensure that the results of clinical trials are unaffected by inadequate safety, quality or efficacy arising from unsatisfactory manufacture, investigational products should be manufactured, packaged, tested, handled, stored and distributed in accordance with an effective quality management system, applicable good practice guidelines and the recommendations contained in this guideline.
- 1.7 Other guidelines and good practices should be taken into account, where relevant, and as appropriate to the stages of development, production and control of the product.
- 1.8 The quality management system should include provision for changes to be made whenever necessary as knowledge of the process increases over time, and in accordance with the stage of development of the product.
- 1.9 Investigational products should be manufactured in a manner:
 - that is compliant with GMP, as appropriate to the stage of development;
 - that ensures that subjects of clinical trials will be protected from poor-quality products resulting from unsatisfactory manufacturing;

- that ensures consistency between and within batches of the investigational product;
- that enables a review of the data derived from the investigational products used against the future commercial product.

- 1.10 The selection of an appropriate dosage form for clinical trials is important. While it is accepted that the dosage form used in early trials may be very different from the anticipated final formulation (for example, a capsule instead of a tablet), in the pivotal phase III studies, it should be similar to the projected commercial presentation; otherwise these trials will not necessarily prove that the marketed product is both efficacious and safe. If there are differences between the clinical trial dosage form and commercial dosage forms, scientific justification and data should be submitted to the registration authorities to demonstrate that the final dosage form is equivalent, in terms of bioavailability and stability, to that used in the clinical trials.
- 1.11 The quality control of investigational products should be appropriate to the stage of development. For example, dosage forms in phase III clinical studies should be characterized and assured at a similar level as for commercially manufactured products.
- 1.12 Where production or quality control is transferred from one site to another, the recommendations in the guideline for transfer of technology should be considered (2).
- 1.13 This document should be read in conjunction with other WHO good practice guidelines (3–11).

2. Scope

- 2.1 The recommendations in this guideline are applicable to investigational products for human use.

3. Glossary

The definitions given below apply to the terms used in this guideline. They have been aligned as much as possible with the terminology in related WHO guidelines and good practices and included in the WHO *Quality Assurance of Medicines Terminology Database: list of terms and related guideline*,¹ but may have different meanings in other contexts.

¹ https://www.who.int/docs/default-source/medicines/norms-and-standards/guidelines/mqa-terminology-sept-2020.pdf?sfvrsn=48461cfc_5.

clinical trial. Any systematic study on pharmaceutical products in human subjects, whether in patients or other volunteers, in order to discover or verify the effects of, or identify any adverse reaction to, investigational products; and to study the absorption, distribution, metabolism and excretion of the products with the object of ascertaining their efficacy and safety.

Clinical trials are generally divided into phases I–IV. It is not possible to draw clear distinctions between these phases, and different opinions about details and methodology exist. However, the individual phases, based on their purposes as related to the clinical development of pharmaceutical products, can be briefly defined as follows:

- **Phase I.** These are the first trials of a new active ingredient or new formulation in humans, often carried out in healthy volunteers. Their purpose is to make a preliminary evaluation of safety, and an initial pharmacokinetic and pharmacodynamic profile of the active ingredient.
- **Phase II.** The purpose of these therapeutic pilot studies is to determine activity and to assess the short-term safety of the active ingredient in patients suffering from a disease or condition for which it is intended. The trials are performed in a limited number of subjects and are often, at a later stage, of a comparative (for example, placebo-controlled) design. This phase is also concerned with the determination of appropriate dose ranges and regimens and (if possible) the clarification of dose–response relationships in order to provide an optimal background for the design of extensive therapeutic trials.
- **Phase III.** This phase involves trials in large (and possibly varied) patient groups for the purpose of determining the short- and long-term safety and efficacy balance of formulations of the active ingredient, and assessing its overall and relative therapeutic value. The pattern and profile of any frequent adverse reactions must be investigated and special features of the product must be explored (for example, clinically relevant drug interactions and factors leading to differences in effect, such as age). The trials should preferably be randomized double-blind trials, but other designs may be acceptable, such as long-term safety studies. In general, the conditions under which the trials are conducted should be as close as possible to the normal conditions of use.
- **Phase IV.** In this phase, studies are performed after the pharmaceutical product has been marketed. They are based on the product characteristics on which the marketing authorization was

granted and normally take the form of post-marketing surveillance and assessment of therapeutic value or treatment strategies. Although methods may differ, the same scientific and ethical standards should apply to phase IV studies as are applied in pre-marketing studies. After a product has been placed on the market, clinical trials designed to explore new indications, new methods of administration or new combinations are normally regarded as trials of new pharmaceutical products.

expiry date. The date placed on the container or label of an investigational product designating the time during which the investigational product is expected to remain within established shelf-life specifications if stored under defined conditions, and after which it should not be used.

investigational product. Any pharmaceutical product, including a new product, existing product for a new indication, reference product or placebo, being tested or used as a reference in a clinical trial.

investigator. The person responsible for the trial and for protecting the rights, health and welfare of the subjects in the trial. The investigator must be an appropriately qualified person, legally allowed to practice medicine or dentistry.

monitor. A person appointed by the sponsor who is responsible for monitoring and reporting the progress of the trial and for the verification of data.

order. An instruction to process, package and ship a certain number of units of an investigational product.

pharmaceutical product. For the purpose of this document, this term is defined in the same way as in the *WHO handbook for good clinical research practices* (4), that is, as any substance or combination of substances that has a therapeutic, prophylactic or diagnostic purpose, or is intended to modify physiological functions, and is presented in a dosage form suitable for administration to humans.

product specification file. The product specification file brings together and contains or refers to all of the essential reference documents to ensure that investigational products are manufactured according to good manufacturing practice for investigational products and the clinical trial authorization. It should be continually updated as development of the product proceeds, ensuring appropriate traceability to the previous versions.

protocol. A document that gives the background, rationale and objectives of the trial and describes its design, methodology and organization, including statistical considerations and the conditions under which it is to be performed

and managed. The protocol should be dated and signed by the investigator or institution involved and the sponsor, and can, in addition, function as a contract.

reference sample. A sample of a batch of starting material, packaging material, product contained in its primary packaging, or finished product that is stored for the purpose of being analysed, should the need arise. This may include storage in a suitable bulk container.

retention sample. A sample of a packaged unit from a batch of finished product for each packaging run or trial period. It is stored for identification purposes – for example, presentation, packaging, labelling, leaflet, batch number and expiry date – should the need arise.

shipping/dispatch. The packing for shipment and sending of ordered products for clinical trials.

sponsor. An individual, company, institution or organization that takes responsibility for the initiation, management and financing of a clinical trial. When an investigator independently initiates and takes full responsibility for a trial, the investigator also then assumes the role of the sponsor.

4. Quality management

- 4.1 There should be a comprehensively designed, clearly defined, documented and correctly implemented quality management system in place. Senior management should assume responsibility for this, as well as for the quality of the investigational product.
- 4.2 All parts of the quality system should be adequately resourced and maintained.
- 4.3 The quality system should incorporate the principles of GMP, which should be applied appropriately to each stage of the development, including technology transfer and the interface between the manufacture and the trial sites (for example, with regard to shipment, storage and labelling).
- 4.4 The quality management system should ensure that:
 - products are designed and developed in accordance with the requirements of this document and other associated guidelines, such as good laboratory practices (3), good clinical practices (4), GMP (5, 6) and good storage and distribution practices (7), where appropriate;
 - responsibilities are clearly defined in job descriptions;
 - operations are clearly described in a written form;

- arrangements are made for the manufacture, supply and use of the correct starting and packaging materials;
- all necessary controls on starting materials, intermediate products, bulk products and other in-process controls should be in place;
- maintenance, calibration, qualification and validation are carried out where necessary;
- the finished product is correctly processed and checked according to the defined procedures;
- changes are appropriately managed and documented, and records are maintained;
- deviations are investigated and recorded with an appropriate level of root cause analysis done and appropriate corrective and preventive actions identified and taken;
- investigational products are stored, distributed and subsequently handled in accordance with relevant good practice guidelines.

5. Quality risk management

- 5.1 There should be a system for quality risk management (8).
- 5.2 The system for quality risk management should cover a systematic process for the assessment, control, communication and review of risks to the quality of the product and, ultimately, to the protection of the trial subjects and patients.
- 5.3 The quality risk management system should ensure that:
- the evaluation of the risk is based on scientific knowledge and experience with the process and product;
 - procedures and records for quality risk management are retained;
 - the level of effort, formality and documentation of the quality risk management process is commensurate with the level of risk.
- 5.4 Quality risk management should be applied both prospectively and retrospectively, as appropriate.

6. Personnel

- 6.1 There should be a sufficient number of appropriately qualified personnel available to carry out all the tasks for which the manufacturer of investigational products is responsible.

- 6.2 Individual responsibilities should be clearly defined, recorded as written descriptions and understood by the persons concerned.
- 6.3 A designated person, with a broad knowledge of product development and clinical trial processes, should ensure that there are systems in place that meet the requirements of this guideline and other relevant good practice guidelines.
- 6.4 Personnel involved in the development, production and control of investigational products should have appropriate qualifications. They should be trained in relevant good practices and the requirements specific to investigational products. All personnel, prior to and during employment, as appropriate, should undergo health examinations. Any person shown at any time to have an apparent illness or open lesions that may adversely affect the quality of products should not be allowed to handle starting materials, packaging materials, in-process materials or products until the condition is no longer judged to be a risk. Records should be maintained. No cosmetics or jewellery should be worn.
- 6.5 Persons responsible for production and quality should be clearly identified and independent from one another, where applicable.
- 6.6 A person should be designated to be responsible for the release of batches.
- 6.7 Appropriate protective garments should be worn, based on operations and risk.
- 6.8 Smoking, eating, drinking, chewing and keeping plants, food, drink, smoking material and personal medicines should not be permitted in any area where they might adversely influence product quality.
- 6.9 Visitors and untrained persons should normally not be allowed into production and quality control areas. When entry is required, it should then be under instruction and close supervision.

7. Documentation

- 7.1 Good documentation is an essential part of a quality management system. Documents should be appropriately designed, prepared, reviewed and distributed. They should also be appropriate for their intended use (12).
- 7.2 Documents should be approved, signed and dated by the appropriate responsible persons. No authorized document should be changed without prior authorization and approval.

7.1 Specifications

7.3 Specifications with limits for impurities and degradation products, where applicable, should be available (for example, for raw materials, starting materials, placebos, and intermediate, bulk and finished products). There should be specifications for packaging materials.

7.4 In developing specifications, attention should be paid to the characteristics that affect the efficacy and safety of products, such as:

- the sterility, potency, assay and other quality attributes of the product (content uniformity can be used for quantitation of drug product assay or unitary dose, where appropriate);
- the release of active ingredients from the dosage form (for example, dissolution profile);
- the suitability of the package size for the requirements of the trial, where applicable;
- the stability of the product, including expected stability where data have been obtained from accelerated conditions, if needed;
- the preliminary storage conditions;
- the shelf-life of the product.

7.5 As a result of new experience in the development of an investigational product, specifications may be changed by following a documented procedure. Changes should be authorized by a responsible person. Each new version should take into account the latest data and information, current technology, and regulatory and pharmacopoeial requirements. There should be traceability of the previous version or versions. The reasons for changes should be recorded. The impact of the change on any ongoing clinical trials, product quality, stability, bioavailability and bioequivalence (where applicable) should be considered, based on risk.

7.2 Order

7.6 An order should be available for the request of a certain number of units for processing, packaging, storage and shipping.

7.7 The order should be given by or on behalf of the sponsor to the manufacturer of an investigational product.

7.8 The order should be in writing (for example, by paper or electronic means, or a combination thereof), be authorized and contain sufficient detail, including reference to the approved product specification file (see below) and the relevant clinical trial protocol, as appropriate.

- 7.9 Where commercially available products are obtained to be used as reference products (for example, for use in bioequivalence studies), the relevant documentation, such as a purchase order, an invoice, and storage and transport records, should be maintained and available for inspection.

7.3 Product specification file

- 7.10 A product specification file (or files) should contain, or refer to, files containing all the information necessary to prepare detailed written instructions on processing, packaging, quality control testing, batch release, storage conditions and shipping.
- 7.11 The information should form the basis for assessment of the suitability for certification and release of a particular batch by the designated responsible person. It should include, or refer to, the following documents (13):
- specifications and analytical methods for starting materials, packaging materials, intermediate product, bulk product and finished product;
 - manufacturing methods;
 - in-process testing and methods;
 - approved label copy;
 - relevant clinical trial authorizations and amendments thereof, clinical trial protocol and randomization codes, as appropriate;
 - relevant technical agreements with contract givers and acceptors, as appropriate;
 - stability plan and reports;
 - storage and distribution conditions;
 - details of the supply chain, including manufacturing, packaging, labelling and testing sites for the investigational products, preferably in the format of a comprehensive diagram.

Note: The contents will vary depending on the product and stage of development. Where different manufacturing steps are carried out at different locations, it is acceptable to maintain separate files limited to information of relevance to the activities at the respective locations.

7.4 Manufacturing formulae and processing instructions

- 7.12 Every manufacturing operation or supply should have clear written instructions for personnel, based on the relevant product specification file and trial details, and written records to enable the details of activities to be reconstructed.

- 7.13 As a result of new experience in the development of an investigational product, manufacturing formulae and processing instructions may be changed by following a documented procedure. Each new version should take into account the latest data and information, current technology, and regulatory and other requirements. There should be traceability to previous versions. The reasons for changes should be recorded. The impact of the change on any ongoing clinical trial, product quality, stability, bioavailability and bioequivalence (where applicable) should be considered, based on risk. Changes should be authorized by a responsible person.
- 7.14 Batch processing and packaging records, as well as product specification files, should be retained for a defined period of time.
- 7.15 Where the data are intended for inclusion in an application for product registration (marketing authorization) purposes, the records should be maintained for 30 years from authorization or until the end of the life cycle of the product, whichever is shorter.

7.5 Packaging instructions

- 7.16 The theoretical number of units to be packaged should be specified before the start of the packaging operation. This should include the number of units necessary for carrying out quality controls and the number of samples from each batch used in the clinical trial to be kept as retention samples. Reconciliation of units packed and primary labels should be carried out at defined intervals, where required, and at the end of the packaging and labelling process.
- 7.17 Investigational products should normally be packed individually for each subject included in the clinical trial.

7.6 Labelling instructions

- 7.18 Labelling should be performed by a site authorized by the sponsor, under the supervision of an appropriately qualified individual (for example, a health care professional or clinical trial monitor) and checked by a second person, in accordance with GMP principles and standard operating procedures. This additional labelling should be recorded in both the trial documentation and in the batch records.
- 7.19 Investigational products should be labelled in accordance with relevant legislation or best practices. Examples of information that the label should include are as follows:

- the name, address and telephone number of the sponsor, contract research organization or investigator;
- the statement “For clinical research use only”, or similar wording;
- a reference number indicative of the trial, site, investigator and sponsor, if not given elsewhere;
- a batch or code number;
- the trial subject, patient identification number and a treatment code;
- a reference to the directions or instructions for use;
- information on storage conditions;
- an expiry date, use-by date or retest date (month and year) or similar, where appropriate;
- a dosage form and route of administration;
- whether for single or multiple use, where applicable;
- the quantity of dosage units and, in the case of open trials, the name or identifier and the strength or potency.

7.20 Additional information may be displayed in accordance with the order (such as treatment period, standard warnings).

7.21 When necessary for blinding purposes, the batch number may be provided separately (see also section 11.3 below).

7.22 A copy or electronic record of each type of label should be kept in the batch packaging record.

7.23 The address and telephone number of the main contact for information on the product or clinical trial, and for emergency unblinding, need not appear on the label where the subject has been given a leaflet or card that provides those details and has been instructed to keep that information in their possession at all times.

7.24 Particulars should appear in the official language or languages of the country in which the investigational product is to be used. This may be provided electronically.

7.25 Where all the required information cannot be displayed on primary packaging, secondary packaging should be provided bearing a label with those particulars. The primary packaging should nevertheless contain information such as the name of sponsor, contract research organization or investigator; route of administration; batch or code number; trial reference code; and the trial subject identification number or treatment code. Where

required, for example in open label trials, the product name and strength of the product should be displayed.

- 7.26 Symbols or pictograms may also be used or included to clarify certain information. Warnings and handling instructions may be displayed.
- 7.27 If it becomes necessary to change the use-by date, an additional label should be affixed to the investigational product. This additional label should state the new use by date and repeat the batch number. The original batch number should remain visible. This labelling activity should be performed in accordance with GMP principles and standard operating procedures and should be checked by a second person. This additional labelling should be recorded both in the trial documentation and in the batch records.

7.7 Batch manufacturing, packaging and testing records

- 7.28 Processing, packaging and testing records should be kept in sufficient detail for the sequence of operations to be accurately traced.

7.8 Coding (or randomization) systems

- 7.29 Procedures should be established for the generation, security, distribution, handling and retention of any randomization code used in packaging investigational products and code-break mechanisms. The appropriate records should be maintained.
- 7.30 The coding system must permit the determination of the identity of the actual treatment product received by individual subjects, without delay, in an emergency situation.

8. Premises

- 8.1 Premises where investigational products are manufactured should be located, designed, constructed and maintained to suit the operations to be carried out.
- 8.2 The layout and design of premises should aim to minimize the risk of errors and mix ups and permit effective cleaning and maintenance in order to avoid contamination, cross-contamination and, in general, any adverse effect on the quality of the products. Where possible, the use of unidirectional flows for personnel, materials, products and waste should be established and maintained.
- 8.3 Attention should be paid to line clearance in order to avoid mix-ups.

- 8.4 Validated or verified cleaning and sanitization procedures, as appropriate, should be followed in order to prevent cross-contamination. Since the characteristics and toxicity of some investigational materials may not be fully known, cleaning is of particular importance to avoid cross-contamination. The visual inspection after cleaning, sampling and test procedures should be appropriate and the acceptance limits applied should be scientifically justifiable. Cleaning and sanitizing agents should not become a source of contamination.
- 8.5 Where identified through risk assessment, campaign production should be considered. In other cases based on risk, dedicated and self-contained facilities should be considered.
- 8.6 Ingress of contaminants should be avoided and controls should be implemented to prevent contamination of the environment, as required.

9. Equipment and utilities

- 9.1 Equipment and utilities should be selected, located, constructed, qualified (as appropriate) and maintained to suit the operations to be carried out.
- 9.2 The layout, design, installation and use of equipment and utilities should aim to minimize the risk of errors and permit effective cleaning and maintenance in order to avoid cross-contamination, a build-up of dust or dirt and, in general, any adverse effect on the quality of products, and should support reproducibility and robustness of the process.
- 9.3 Computerized systems used to acquire, process and store GMP data should be validated. The extent of validation should be based on risk assessment (8).

10. Materials

10.1 Starting and packaging materials

- 10.1 The consistency of the production of investigational products may be influenced by the quality of the starting materials. Their physical, chemical and, when appropriate, microbiological properties should therefore be defined, documented in their specifications, and controlled.
- 10.2 Existing compendial standards, when available, should be used.
- 10.3 Specifications for active ingredients and excipients should be as comprehensive as possible, given the current state of knowledge.

- 10.4 Specifications for both active ingredients and excipients should be reassessed and updated when required.
- 10.5 In addition to the specifications, detailed information on the active ingredients, excipients and packaging materials should be available. This includes materials of animal origin.

10.2 Chemical and biological reference standards for analytical purposes

- 10.6 Reference standards (WHO or national standards) should be used, if available. Otherwise, the reference substances for the active ingredients should be prepared, tested and authorized for use as reference materials by the producer of the investigational product, or by the producer of the active ingredients used in the manufacture of that product (10).

10.3 Principles applicable to reference products for clinical trials

- 10.7 In a study where an investigational product is being compared to a marketed product, the integrity and quality of the reference (such as final dosage form, packaging materials or storage conditions) should be ensured.
- 10.8 If significant changes are to be made in the product, data should be available (for example, on stability and comparative dissolution) that demonstrate that those changes do not influence the original quality characteristics of the product.

11. Production

- 11.1 Products intended for use in clinical trials should be manufactured in accordance with the requirements of this guideline and, where required by national legislation, in licensed facilities. Manufacturing operations should be controlled as appropriate to the phase of development and scale of manufacture.
- 11.2 Where activities are outsourced to contract facilities and the products to be manufactured or controlled are intended for use in clinical trials, the contract must then clearly state the responsibilities of each party in compliance with this guideline and WHO GMP (5). Close cooperation between the contracting parties is essential.

11.1 Manufacturing operations

- 11.3 As process validation may not always be complete during the development phase of products, provisional quality attributes, process parameters and in-process controls should be identified, based on risk management principles and experience with the products or analogous products.
- 11.4 The necessary processing instructions should be identified and may be adapted, based on the experience gained in production.
- 11.5 Where processes such as mixing have not been validated, additional quality control testing may be necessary.
- 11.6 For sterile investigational products, the sterility assurance should be no less than for commercial products (11).

11.2 Packaging and labelling

- 11.7 The packaging and labelling of investigational products are likely to be more complex and more liable to errors (which are also harder to detect) when “blinded” labels are used than for commercial products. Supervisory procedures, such as label reconciliation, line clearance, and other controls, including independent checks by quality unit personnel, should be intensified accordingly.
- 11.8 The packaging must ensure that the investigational product remains in good condition during transport and storage, within specified limits of temperature, relative humidity and light, as appropriate. Any opening of, or tampering with, the outer packaging during transport should be readily visible.

11.3 Blinding operations

- 11.9 In the preparation of blinded products, the blind should be maintained until it is required to enable its identification.
- 11.10 A coding system should be introduced to permit the identification of blinded products, also in the case of an emergency. The code, together with the randomization list, must enable the identification of the product, including any necessary traceability to the codes and batch number of the product before the blinding operation.
- 11.11 Controls should be applied to verify the similarity in appearance and other physical characteristics, such as the odour and colour of blinded investigational products. Maintenance of blinding during the study should

be ensured and verification of the effectiveness of blinding should be performed and recorded.

12. Quality unit (including quality control)

- 12.1 Quality control should cover, for example, the sampling and testing of materials and products. The analytical procedures should be suitable for their intended purpose, ensuring that materials and products are not released for use or supply until their quality has been judged to be compliant with the specifications.
- 12.2 Each batch of product should be tested in accordance with the specifications included in the product specification file and should meet its acceptance criteria.
- 12.3 Bulk product release should cover all relevant factors, including production conditions, the results of in-process testing, a review of manufacturing documentation, and compliance with the product specification file and the order. Finished product release should cover, in addition to the bulk product assessment, all relevant factors, including packaging conditions, the results of in-process testing, a review of packaging documentation and compliance with the product specification file and the order.
- 12.4 Reference and retention (control) samples of each batch of product should be retained.
- 12.5 Retention samples should be kept until the clinical report has been submitted to the regulatory authorities or at least two years after the termination or completion of the relevant clinical trial, whichever is longest. This is in order to enable the confirmation of product identity in the event of, and as part of an investigation into, inconsistent trial results.
- 12.6 The storage location of reference and retention samples should be defined in a technical agreement between the sponsor and manufacturer and should enable timely access by the competent authorities.
- 12.7 The retained sample should be of sufficient size to perform the full analytical controls at least twice on the batch in accordance with the investigational product dossier submitted for authorization in order to conduct the clinical trial.
- 12.8 Where data and information are stored as electronic records, such systems should comply with the requirements of WHO guidelines for computerized systems (9).

12.9 The release of a batch of an investigational product should only occur after the designated responsible person and sponsor, as required, have certified that the product meets the relevant requirements. These requirements include the assessment of, as appropriate:

- batch records, including control reports, in-process test reports, changes, deviations and release reports demonstrating compliance with the product specification file, the order, and randomization code;
- production conditions;
- the qualification status of facilities and the validation status of processes and methods, as appropriate;
- the examination of finished packs;
- where relevant, the results of any analyses or tests performed after importation;
- stability reports;
- the source and verification of conditions of storage and shipment;
- audit reports concerning the quality system of the manufacturer, where applicable;
- documents certifying that the manufacturer is authorized to manufacture investigational products or comparators for export by the appropriate authorities in the country of export;
- where relevant, regulatory requirements for marketing authorization, GMP standards applicable and any official verification of GMP compliance.

Note: The relevance of the above elements is affected by the country of origin of the product, the manufacturer and the marketed status of the product.

13. Qualification and validation

13.1 The scope of qualification and validation required should be determined based on risk assessment.

13.2 For sterile products, there should be no reduction in the degree of validation of sterilizing equipment required. Validation of aseptic processes presents special problems when the batch size is small due to the low number of units filled for a validation exercise. Filling and sealing, which is often done by hand, can compromise the maintenance of sterility. Enhanced

attention should be given to operator training and the qualification of their aseptic technique. Sterility testing methods should be validated.

13.3 Attention should also be given to environmental monitoring.

14. Complaints

14.1 There should be a written procedure describing the managing of complaints.

14.2 Any complaint concerning a product defect should be recorded with all the original details and thoroughly investigated.

14.3 Where necessary, appropriate follow-up action, possibly including product recall, should be taken after investigation and evaluation of the complaint.

14.4 All decisions made and measures taken as a result of a complaint should be recorded.

14.5 The competent authorities should be informed if a manufacturer is considering action following the identification of serious quality problems with a product that may be impacting trial subjects or patients.

14.6 The conclusions of the investigations carried out in response to a complaint should be discussed between the manufacturer and the sponsor (if different) or between the persons responsible for manufacture and those responsible for the relevant clinical trial in order to assess any potential impact on the trial and on the product development, and to determine the cause and take any necessary corrective action.

15. Recalls

15.1 There should be a written procedure describing the managing of a recall of investigational products.

15.2 Recall procedures should be understood by the sponsor, investigator and monitor, in addition to the person or persons responsible for recalls.

15.3 The recall of a product should be documented and inventory records should be kept.

15.4 The recall process should be tested routinely and the results of mock recall should be recorded to demonstrate effectiveness.

16. Returns

- 16.1 There should be a written procedure describing the managing of returns of investigational products. The returns should be under agreed conditions, as defined by the sponsor.
- 16.2 Returned investigational products should be clearly identified and stored in a dedicated area in a controlled manner.
- 16.3 Inventory records of returned products should be kept.

17. Shipping

- 17.1 The shipping of investigational products should be carried out in accordance with written procedures laid down in the protocol or shipping order given by the sponsor.
- 17.2 Acceptable shipping conditions, including temperature and light protection, based on product attributes, phase-appropriate stability data and risk assessment, should be observed. If required, a calibrated temperature monitor should be kept adjacent to the product, and the product shipment should be packaged appropriately to ensure that it will reach its destination intact and maintain the appropriate temperature profile during that time.
- 17.3 A shipment is sent to an investigator after following the defined release procedures, for example, quality control, certification and authorization by the sponsor and responsible person, as appropriate. Releases should be recorded.
- 17.4 The sponsor should ensure that the shipment will be received and acknowledged by the correct addressee, as stated in the protocol.
- 17.5 A detailed inventory of the shipments made by the manufacturer should be maintained and should make particular mention of the addressee's identification.
- 17.6 The transfer of investigational products from one trial site to another should be done in exceptional cases only. Such transfers should be justifiable, documented and carried out in accordance with a written procedure. Repackaging or relabelling should normally be done by the manufacturer or by authorized personnel at a hospital, health centre or clinic that meets the requirements. Records should be maintained and provide full traceability of the product, batch and activities.

18. Destruction

- 18.1 The sponsor is responsible for the destruction of unused, partially used or returned investigational products. These should normally not be destroyed by the manufacturer without prior authorization by the sponsor.
- 18.2 Destruction operations should be carried out in accordance with written procedures and environmental safety requirements.
- 18.3 The delivered, used and recovered quantities of a product should be recorded, reconciled and verified by or on behalf of the sponsor for each trial site and each trial period. The destruction should be carried out only after any discrepancies have been investigated and satisfactorily explained, and the reconciliation has been accepted.
- 18.4 Destruction operations should be recorded in such a manner that all operations are accounted for. These records should be kept by the sponsor.
- 18.5 A certificate of destruction should be available containing the necessary detail to enable traceability of the product, batch and related information.

References

1. Good manufacturing practices: supplementary guidelines for the manufacture of investigational pharmaceutical products for clinical trials in humans. In: WHO Expert Committee on Specifications for Pharmaceutical Preparations: thirty-fourth report. WHO Technical Report Series No. 863, Annex 7. Geneva: World Health Organization; 1996 (<https://apps.who.int/iris/handle/10665/41849>, accessed 16 August 2022).
2. WHO guidelines on technology transfer in pharmaceutical manufacturing. In: WHO Expert Committee on Specifications for Pharmaceutical Preparations: fifty-sixth report. WHO Technical Report Series No. 1044, Annex 4. Geneva: World Health Organization; 2022.
3. Handbook: Good laboratory practice: quality practices for regulated non-clinical research and development. Geneva: World Health Organization; 2001 (<https://apps.who.int/iris/handle/10665/66894>, accessed 16 August 2022).
4. Handbook for good clinical research practice (GCP): guidance for implementation. Geneva: World Health Organization; 2005 (<https://apps.who.int/iris/handle/10665/43392>, accessed 30 August 2022).
5. WHO good manufacturing practices for pharmaceutical products: main principles. In: WHO Expert Committee on Specifications for Pharmaceutical Preparations: forty-eighth report. WHO Technical Report Series No. 986, Annex 2. Geneva: World Health Organization; 2014 (<https://apps.who.int/iris/handle/10665/112733>, accessed 16 August 2022).
6. WHO good manufacturing practices for active pharmaceutical ingredients. In: WHO Expert Committee on Specifications for Pharmaceutical Preparations: forty-fourth report. WHO Technical Report Series No. 957, Annex 2. Geneva: World Health Organization; 2010 (<https://apps.who.int/iris/handle/10665/44291>, accessed 28 September 2022).

7. Good storage and distribution practices for medical products. In: WHO Expert Committee on Specifications for Pharmaceutical Preparations: fifty-fourth report. WHO Technical Report Series No. 1025, Annex 7. Geneva: World Health Organization; 2020 (<https://apps.who.int/iris/handle/10665/331814>, accessed 28 September 2022).
8. WHO guidelines on quality risk management. In: WHO Expert Committee on Specifications for Pharmaceutical Preparations: forty-seventh report. WHO Technical Report Series No. 981, Annex 2. Geneva: World Health Organization; 2013 (<https://apps.who.int/iris/handle/10665/81144>, accessed 28 September 2022).
9. WHO good manufacturing practices: guidelines on validation. Appendix 5: Validation of computerized systems. In: WHO Expert Committee on Specifications for Pharmaceutical Preparations: fifty-third report. WHO Technical Report Series No. 1019, Annex 3. Geneva: World Health Organization; 2019 (<https://apps.who.int/iris/handle/10665/312316>, accessed 28 September 2022).
10. General guidelines for the establishment, maintenance and distribution of chemical reference substances. In: WHO Expert Committee on Specifications for Pharmaceutical Preparations: forty-first report. WHO Technical Report Series No. 943, Annex 3. Geneva: World Health Organization; 2007 (<https://apps.who.int/iris/handle/10665/43632>, accessed 28 September 2022).
11. WHO good manufacturing practices for sterile pharmaceutical products. In: WHO Expert Committee on Specifications for Pharmaceutical Preparations: fifty-sixth report. WHO Technical Report Series No. 1044, Annex 2. Geneva: World Health Organization; 2022.
12. Guideline on data integrity: section 10, good documentation practices. In: WHO Expert Committee on Specifications for Pharmaceutical Preparations: fifty-fifth report. WHO Technical Report Series No. 1033, Annex 4. Geneva: World Health Organization; 2021 (<https://apps.who.int/iris/handle/10665/340323>, accessed 28 September 2022).
13. EudraLex – Volume 10 – Clinical trials guidelines. Chapter III, Detailed Commission guidelines on good manufacturing practice for investigational medicinal products for human use, pursuant to the second subparagraph of Article 63(1) of Regulation (EU) No 536/2014. European Commission; 2017.

Further reading

- The International Pharmacopoeia. Geneva: World Health Organization; updated regularly.
- International Ethical Guidelines for Health-related Research Involving Humans Prepared by the Council for International Organizations of Medical Sciences (CIOMS) in collaboration with the World Health Organization (WHO), Geneva, 2016. Geneva: CIOMS; 2016.
- EudraLex – Volume 4 – Good Manufacturing Practice (GMP) guidelines. EU Commission Directives 91/356/EEC, as amended by Directive 2003/94/EC and 91/412/EEC.
- Current good manufacturing practice in manufacturing, processing, packing, or holding of drugs: general. Code of Federal Regulations, Title 21, Part 201. U.S. Department of Health and Human Services: Food and Drug Administration; 2022.

Annex 8

Points to consider for setting the remaining shelf-life of medical products upon delivery

Edit and republication of *Points to consider for setting the remaining shelf-life of medical products upon delivery*, WHO Technical Report Series No. 1025, Annex 8, with a new Appendix 2.

Background

Following the publication of *Points to consider for setting the remaining shelf-life of medical products upon delivery* in 2020, a group from international agencies and humanitarian organizations procuring health kits (including the International Committee of the Red Cross, Médecins Sans Frontières, Save the Children, United Nations Children’s Fund, United Nations Population Fund and the World Health Organization) submitted a draft proposal for an amendment to include emergency health kits used as part of the humanitarian response as an additional example for consideration. During the fifth-sixth WHO Expert Committee on Specifications for Pharmaceutical Preparations, the *Points to consider for setting the remaining shelf-life of medical products upon delivery* guideline with a new Appendix 2 (*Example of minimum remaining shelf-life of emergency health kits used as part of the humanitarian response*) was adopted.

Contents

Background	301
1. Introduction	303
2. Scope	304
3. Glossary	304
4. The need for recommendations	306
5. Remaining shelf-life	307
5.1 Principles	307
5.2 Expiry date	309
5.3 Retesting	309
References	309



Appendix 1	Example of minimum remaining shelf-life of medical products	311
Appendix 2	Example of minimum remaining shelf-life for emergency health kits for use as part of humanitarian response	312

1. Introduction

Following discussions relating to establishing a document for the remaining shelf-life of medical products upon delivery, and considering the discussion between representatives of the Interagency Pharmaceutical Coordination Group, it was decided to initiate a project to prepare a document on remaining shelf-life for procurement and supply of medical products.

The concept and project to prepare such a document was also discussed during the meeting of the fifty-third Expert Committee on Specifications for Pharmaceutical Products in October 2018. It was noted that some guidance documents were available from different procurement agencies. It was agreed that the World Health Organization (WHO) would initiate the discussion and preparation of a document, while following the WHO process for the establishment of such a paper.

Information and policy on remaining shelf-life was collected from different agencies and interested parties and a first draft document was prepared after an informal discussion meeting in Geneva, Switzerland, in January 2019.

It was then agreed that the document should cover not only finished pharmaceutical products but should be extended to cover other products, including medical devices, vaccines and in vitro diagnostics (IVD) products. (These products are collectively referred to as “medical products” hereafter.)

A draft document was prepared and circulated to members of the Interagency Pharmaceutical Coordination Group and other interested parties, inviting comments. The comments received were reviewed during an informal discussion meeting in June 2019 and the draft document was updated.

The aims of this document are:

- to facilitate the national authorization of importation of medical products, where applicable;
- to promote and support the efficient processing of medical products in the supply chain at all levels and thus prevent wastage because of delays;
- to assist in ensuring that there is sufficient stock of medical products, with acceptable remaining shelf-life, in-country;
- to prevent dumping of medical products;
- to ensure that barriers to access and supply of medical products are addressed;
- to prevent out-of-stock situations;
- to prevent receipt of donations of medical products that are not in accordance with this guideline;
- to prevent having expired stock of medical products.

The document is intended to provide guidance on setting the remaining shelf-life of medical products upon delivery and should be considered by all stakeholders in the supply chain of medical products. It is also recommended that the recommendations herein should be considered for inclusion in the national policy of countries.

2. Scope

The principles contained in this document should be applied to medical products in the supply chain. This includes donated products (1).

This document focuses on remaining shelf-life and does not address details contained in other guidelines, guides and agreements between different parties in the supply chain.

While the principles contained in this guideline apply to humanitarian emergency health kits, “kits” are made up of different products, owing to certain specifics related to the shelf-life of kits. These considerations are outlined in Appendix 2.

All stakeholders, including national regulatory authorities, manufacturers, suppliers, donors and recipients, should consider the recommendations on remaining shelf-life contained in this document.

3. Glossary

The definitions given below are taken from existing WHO guidelines, where available, or alternatively from other recognized guidelines.

batch. A defined quantity of starting material, packaging material or product, processed in a single process or series of processes, so that it is expected to be homogeneous. It may sometimes be necessary to divide a batch into a number of sub-batches, which are later brought together to form a final homogeneous batch. In the case of terminal sterilization, the batch size is determined by the capacity of the autoclave. In continuous manufacture, the batch must correspond to a defined fraction of the production, characterized by its intended homogeneity. The batch size can be defined either as a fixed quantity or as the amount produced in a fixed time interval.

consignment (or delivery). The quantity of a medical product or products, made by one manufacturer and supplied at one time in response to a particular request or order. A consignment may comprise one or more packages or containers and may include material belonging to more than one batch.

expiry date (or expiration date). The date placed on the container or labels of a medical product designating the time during which it is expected to remain within established shelf-life specifications if stored under defined conditions, and after which it should not be used.

finished pharmaceutical product. A product that has undergone all stages of production, including packaging in its final container and labelling. A finished pharmaceutical product may contain one or more active pharmaceutical ingredients.

install-by date. The date by which an instrument, device or other has to be installed.

manufacture. All operations of purchase of materials and products, production, quality control, release, storage and distribution of medical products, and the related controls.

manufacturer. A company that carries out operations such as production, packaging, repackaging, labelling and relabelling of medical products.

manufacturer (in vitro diagnostics). Any natural or legal person with responsibility for design and/or manufacture of an IVD product with the intention of making it available for use under their name, whether or not such a product is designed and/or manufactured by that person or on their behalf.

manufacturing date. The date of production of a batch is defined as the date that the first step is performed involving combination of the active ingredient with other ingredients. Where there are no other ingredients than an active ingredient, the date of the start of the processing or filling operation is considered as the date of production.

marketing authorization (product licence, registration certificate). A legal document issued by the competent medicines regulatory authority that establishes the detailed composition and formulation of the product and the pharmacopoeial or other recognized specifications of its ingredients and of the final product itself, including details of packaging, labelling and shelf-life.

medical product. Medical products include a wide range of manufactured items, such as finished pharmaceutical products, medical devices, vaccines and IVD products.

pharmaceutical product. Any material or product intended for human or veterinary use presented in its finished dosage form, or as a starting material for use in such a dosage form, that is subject to control by pharmaceutical legislation in the exporting state or the importing state.

production. All operations involved in the preparation of a product, from receipt of materials, through processing, packaging and repackaging, labelling and relabelling, to completion of the finished product.

remaining shelf-life. The period remaining from the date of delivery to the expiry date, retest date, install-by date or other use-before date established by the manufacturer.

retest date. The date when a material should be re-examined to ensure that it is still suitable for use.

shelf-life. The period of time, from the date of manufacture, that a product is expected to remain within its approved product specification while handled and stored under defined conditions.

upon delivery. The date a medical product is delivered as specified, for example at the port, at the point in-country after customs clearance, or at the end user, and as defined in the agreement between relevant parties.

4. The need for recommendations

As there was no harmonized approach on remaining shelf-life for medical products amongst procurers, donors and recipient countries, it was agreed that it would be beneficial to have a harmonized approach when considering remaining shelf-life. This will assist national regulatory authorities (NRAs), suppliers, donors, procurers, importers and distributors to manage medical products throughout the supply chain, thus ensuring that quality medical products reach the end user within their remaining shelf-life. The authorization of importation of medical products by NRAs sometimes delays access to medical products. A harmonized approach among countries may facilitate authorization and release of medical products in the supply chain in a timely manner.

This is not a stand-alone document. It should be read with other documents, guides and guidelines, including WHO guidelines such as *Guidelines for medicines donations* (1), *Stability testing of active pharmaceutical ingredients and finished pharmaceutical products* (2), *Good storage and distribution practices for medical products* (3), *Model quality assurance system for procurement agencies* (4), *The International Pharmacopoeia* (5) and guidelines of the International Council for Harmonisation of Technical Requirements for Registration of Pharmaceuticals for Human Use.

5. Remaining shelf-life

Note: The manufacturing date of a medical product should be defined by the manufacturer and be provided, if requested.

5.1 Principles

Decisions on remaining shelf-life for medical products should be defined realistically, contextualized and adapted to each importer, following a thorough risk assessment taking into account the criteria below (at the end of this subsection). Remaining shelf-life should be defined based on relevant factors, including the category and type of product, inventory level, manufacturing and transit lead time, local release lead time, storage conditions, delivery chain, and resources in the recipient country or region.

There should be agreements between suppliers, purchasers and recipients covering the relevant responsibilities of each party, including remaining shelf-life or expiry date.

Products should be transported, received, stored and distributed in accordance with WHO *Good storage and distribution practices for medical products* (3). Special attention should be given to temperature-, light- and moisture-sensitive products.

Products supplied by the manufacturer or supplier should meet the policy of national government and the recommendations in terms of remaining shelf-life prescribed in this document.

Products should be appropriately labelled. The label should include the expiry, retest or install-by date, as appropriate. Products with an install-by date should be installed prior to the date specified by the supplier.

Products received should be scrutinized in an attempt to identify possible substandard and falsified products. It should be ensured that, for example, the expiry date is not falsified (6).

Where different periods for remaining shelf-life have been defined for products, recipients should ensure that the products meet the remaining shelf-life requirement for the intended destination, such as central warehouse, regional warehouse, testing site or user point.

National authorization for importation, where required, should be obtained based on the available information, including the expiry date of the product, to enable calculation of the remaining shelf-life and to assist in expediting approval.

Where so justified, suppliers, recipients and national authorities may negotiate deviations from the policy for remaining shelf-life, provided that:

- where the remaining shelf-life is shorter than stipulated in the policy, it is ensured that the stock will be consumed prior to expiry;

- the medical product reaches end users with adequate remaining shelf-life to permit confidence that there is time to consume it before expiry.

Risk assessment should be carried out to ensure that the parameters listed above are met, taking into account the following considerations:

- assessment of need;
- type of product: different criticality for the safety of the patient between pharmaceutical products, vaccines, medical devices and IVD products;
- expiry date: with this information, the remaining shelf-life at delivery time can be estimated;
- compliance with WHO guidelines on *Good storage and distribution practices for medical products* (3);
- delivery time to storage facility;
- storage conditions;
- stock rotation;
- delivery time from storage to end user;
- frequency of stock replenishment or order frequency (based on consumption): recipients and end users should regularly verify that medical products in stock are rotated or used within their remaining shelf-life, and adjust the quantities ordered to make sure that the medical products will be used during their remaining shelf-life;
- assessment of real needs, to ensure that the medical products can be used within their shelf-life;
- emergencies: during an emergency situation, the remaining shelf-life policy should be well balanced to ensure that lifesaving medical products will be received on time, and that the needs will be covered if there is an increased demand;
- logistic set-up: the location of the premises, the number of means or types of transportation (for example, the number of vehicles), and its adaptability will have an impact on the speed of delivery and, hence, on the confidence that products will be used before their expiry date;
- activity specificities: similarly, whether the medical products will be used by the national programme, or are managed directly by the importer outside a national programme, will make a difference in terms of speed of delivery to the end user;

- point of delivery: national warehouses or importer or end user facilities will also have an impact on the speed of delivery.

5.2 Expiry date

Products, such as pharmaceutical products, should have an expiry date allocated by the manufacturer. The expiry date should be established based on the results of stability testing obtained in the relevant packaging (primary and secondary packaging, where appropriate) and required stability conditions (2).

5.3 Retesting

Where a manufacturer or supplier has obtained approval from an NRA for a new or extended shelf-life, this may be applied.

Products with an expiry date should not be subjected to retesting by the purchaser or recipient for the purpose of extension of shelf-life. Only in exceptional cases, such as product shortages, should a recipient consider extending the expiry date of received batches, subject to certain conditions, such as availability of scientific data, the application of risk management principles, and NRA approval. The new expiry date should be reflected on the packaging.

Products with a retest date allocated by a manufacturer, such as chemicals and reagents, may be retested and used if the quality parameters are met.

An illustrative example of recommended remaining shelf-life of products is given in Appendix 1 for bulk medical products and Appendix 2 for the emergency health kits used in humanitarian response.

References

1. Interagency guidelines. Guidelines for medicines donations, third edition. Geneva: World Health Organization; 2011.
2. Stability testing of active pharmaceutical ingredients and finished pharmaceutical products. In: WHO Expert Committee on Specifications for Pharmaceutical Preparations: fifty-second report. WHO Technical Report Series No. 1010, Annex 10. Geneva: World Health Organization; 2018.
3. Good storage and distribution practices for medical products. In: WHO Expert Committee on Specifications for Pharmaceutical Preparations: fifty-fourth report. WHO Technical Report Series No. 1025, Annex 7. Geneva: World Health Organization; 2020.
4. Model quality assurance system for procurement agencies. In: WHO Expert Committee on Specifications for Pharmaceutical Preparations: forty-eighth report. WHO Technical Report Series No. 986, Annex 3. Geneva: World Health Organization; 2014.
5. The International Pharmacopoeia, ninth edition. Geneva: World Health Organization; 2019.
6. WHO guidance on testing of “suspect” falsified medicines. In: WHO Expert Committee on Specifications for Pharmaceutical Preparations: fifty-second report. WHO Technical Report Series No. 1010, Annex 5. Geneva: World Health Organization; 2018.

Further reading

- WHO guidelines for sampling of pharmaceutical products and related materials. In: WHO Expert Committee on Specifications for Pharmaceutical Preparations: thirty-ninth report. WHO Technical Report Series No. 929, Annex 4. Geneva: World Health Organization; 2005.
- WHO good practices for pharmaceutical quality control laboratories. In: WHO Expert Committee on Specifications for Pharmaceutical Preparations: forty-fourth report. WHO Technical Report Series No. 957, Annex 1. Geneva: World Health Organization; 2010.
- Model guidance for the storage and transport of time- and temperature-sensitive pharmaceutical products. In: WHO Expert Committee on Specifications for Pharmaceutical Preparations: forty-fifth report. WHO Technical Report Series No. 961, Annex 9. Geneva: World Health Organization; 2011.
- WHO guidelines on quality risk management. In: WHO Expert Committee on Specifications for Pharmaceutical Preparations: forty-seventh report. WHO Technical Report Series No. 981, Annex 2. Geneva: World Health Organization; 2013.
- WHO good manufacturing practices for pharmaceutical products: main principles. In: WHO Expert Committee on Specifications for Pharmaceutical Preparations: forty-eighth report. WHO Technical Report Series No. 986, Annex 2. Geneva: World Health Organization; 2014.
- Technical supplements to model guidance for storage and transport of time- and temperature-sensitive pharmaceutical products. In: WHO Expert Committee on Specifications for Pharmaceutical Preparations: forty-ninth report. WHO Technical Report Series No. 992, Annex 5. Geneva, World Health Organization; 2015.
- WHO Good manufacturing practices for biological products. In: WHO Expert Committee on Specifications for Pharmaceutical Preparations: fiftieth report. WHO Technical Report Series No. 996, Annex 3. Geneva: World Health Organization; 2016.
- Guidance for procurement of in vitro diagnostics and related laboratory items and equipment. Geneva: World Health Organization; 2017.
- Establishing stability of in vitro diagnostic medical devices. Technical Guidance Series (TGS) for WHO Prequalification: Diagnostic Assessment (TGS2): In: WHO Expert Committee on Biological Standardization: sixty-eighth report. WHO Technical Report Series No. 1011, Annex 5. Geneva: World Health Organization; 2018.
- Establishing component stability for in vitro diagnostic medical devices. Technical Guidance Series (TGS) for WHO Prequalification: Diagnostic Assessment. Annex to TGS2. WHO/MVP/EMP/RHT/PQT/2019.03. Geneva: World Health Organization; 2019.
- ISO 23640:2011. In vitro diagnostic medical devices: evaluation of stability of in vitro diagnostic reagents. International Organization for Standardization.
- EP25-A: Evaluation of stability of in vitro diagnostic reagents: approved guideline. Wayne (PA): Clinical and Laboratory Standards Institute; 2009.

Appendix 1

Example of minimum remaining shelf-life of medical products

Note: The total shelf-life of a product is based on results from testing during stability (and, where relevant, sterility) studies under specified conditions. The storage and transport conditions stipulated by the manufacturer should be followed to ensure that the product quality is maintained.

Table 1

Example of the minimum remaining shelf-life (RSL), at the time of dispatch and upon delivery, of medical products, based on the outcome of risk assessment

Total shelf-life (TSL)	RSL at time of dispatch from manufacturer's premises	RSL at time of delivery at port of entry of country	RSL at time of delivery at end user level
48 months < TSL ≤ 60 months	40 months	30 months	12 months
36 months < TSL ≤ 48 months	30 months	24 months	12 months
24 months < TSL ≤ 36 months	20 months	15 months	6 months
12 < TSL ≤ 24 months	9 months	7 months	3 months
TSL ≤ 12 months	Special arrangements and conditions apply		

Appendix 2

Example of minimum remaining shelf-life for emergency health kits for use as part of humanitarian response

Emergency health kits are designed to facilitate the provision of priority health services in humanitarian emergencies to affected populations without access to medical facilities or where medical facilities are disrupted during a crisis. Depending on the type of emergency health kit, they contain a mix of essential medicines, health supplies and equipment designed to be used for a limited period of time and for a specific number of people.

Many different international and national organizations will be providing these emergency health kits in an acute or post-acute humanitarian response. Some examples of these organizations include:

- International Committee of the Red Cross (ICRC)
- Médecins Sans Frontières (MSF)
- Save the Children
- United Nations Children’s Fund (UNICEF)
- United Nations Population Fund (UNFPA)
- World Health Organization (WHO).

Examples of these kits include interagency emergency health kits, interagency emergency reproductive health kits, MSF emergency health kits, cholera kits, and ICRC surgical team kits. “Kits” manufactured and validated as such are not considered in the amendment (such as in vitro diagnostic kits, laboratory reagent kits or polymerase chain reaction (PCR) kits) and are not intended to be covered by this annex.

Background clarifications

Expiry date of an emergency health kit. Each emergency health kit should have a manufacturing date, defined as an “assembly date”, and an expiry date, defined as the “first item to be expired in the kit”, allocated by the supplier or the manufacturer assembling the kit.

The shelf-life of an emergency health kit is defined by the “first item to be expired in the kit”. In other words, the item in the kit with the shortest expiry date will define the expiry date of the entire kit. This implies that all the other items composing the emergency health kit have the same or a longer shelf-life.

The expiry date of the “first item to be expired in the kit” should follow the principles described in the document. Products, such as pharmaceutical products, should have an expiry date allocated by the manufacturer. The expiry date should be established based on the stability testing results obtained on the relevant packaging (primary and secondary packaging, where appropriate) and the required stability conditions. These are presented in the number of years, based on the calculation from the date of manufacture.

Remaining shelf-life of an emergency health kit. The remaining shelf-life is calculated based on the expiry date, storage conditions and risks. The remaining shelf-life of an emergency health kit should consider the expiry date of the entire kit (see definition of expiry date of an emergency health kit above) as the end date of possible use of the kit.

Criteria that influence the recommended remaining shelf-life are the purpose of the emergency kit (immediate response or prepositioning) and the phase of the emergency – acute or post-acute (protracted or recovery). Emergency health kit prepositioning requires that careful attention be paid to stock rotation in order to ensure that expiry dates do not arrive before use.

Examples of remaining shelf-life (RSL) at the different point of delivery for the shelf-life, up to the total shelf-life (TSL), are laid out in Table 2.

Table 2

Example of the minimum remaining shelf-life (RSL), at the time of dispatch and upon delivery, of emergency health kits, based on the outcome of risk assessment

Expiry date (as defined above)	RSL at time of dispatch from supplier's premises	RSL at time of delivery at port of entry of country	RSL at time of delivery at end user level
Acute emergency response^a			
Greater than 48 months	24 months	12 months	6 months
36 months < TSL ≤ 48 months	20 months	12 months	6 months
24 months < TSL ≤ 36 months	16 months	12 months	6 months
15 months < TSL ≤ 24 months	12 months	7 months	3 months
15 months or less	Special arrangements and conditions apply ^b		
Prepositioning in preparedness or post-acute emergency response^c			
Greater than 48 months	40 months	30 months	12 months
36 months < TSL ≤ 48 months	30 months	24 months	12 months

Table 2 *continued*

Expiry date (as defined above)	RSL at time of dispatch from supplier's premises	RSL at time of delivery at port of entry of country	RSL at time of delivery at end user level
24 months < TSL ≤ 36 months	18 months	15 months	6 months
15 months < TSL ≤ 24 months	14 months	12 months	3 months
15 months or less	Special arrangements and conditions apply ^b		

^a An acute emergency refers to a period of time when there are sudden, often unpredicted, humanitarian needs due to a natural or human-induced crisis, where the complexities of the crisis setting lead to added complexities in the delivery of humanitarian response, or where the scale of humanitarian needs exceeds the capacity of local or national actors; this may or may not refer to an official or unofficial scale-up of a coordinated interagency response.

^b There are some items that will never have more than 12 months of total shelf-life.

^c A post-acute emergency refers to a period of time when there are significant humanitarian needs due to a natural or human-induced crisis, where the complexities of the crisis setting have remained stable for a significant period of time (protracted) or where the crisis has begun to subside, with an implied gradual return to stability (recovery).

It should be kept in mind that when an emergency health kit has expired, many of the items in the kit will still be viable for use. The expired items should be disposed of and replaced in a manner that maintains the integrity and quality of the kit. In cases where these cannot be replaced, the remaining items can be used as bulk individual items and integrated into the health system, provided these individual components of the kits have been manufactured for dedicated use as a “single product” and stored and repackaged according to the approved stability and packaging conditions.

Annex 9

WHO/UNFPA guidance on natural rubber latex male condom stability studies

Contents

1. Introduction	316
2. Storage and ageing conditions	317
3. Stability of condoms	319
3.1 Oxidation	319
3.2 Ozone	321
3.3 Light	321
3.4 Thermal stability	322
3.5 Continuing vulcanization	322
4. Overview of methods determining the shelf-life of condoms	323
5. Determination of shelf-life according to ISO 4074:2015	324
6. Practical guidance	326
6.1 Selection of condoms	326
6.2 Samples and storage	326
6.3 Testing	327
6.4 Reporting	328
References	328
Appendix 1 Summary procedures for conducting stability studies	330



1. Introduction

Manufacturers of natural rubber latex male condoms are required by regulatory bodies to establish the shelf-life of their products prior to placing them on the market. The methods and data used to establish the shelf-life are assessed as part of the regulatory review processes. The United Nations Population Fund (UNFPA) also requires data supporting shelf-life claims to be submitted as part of the prequalification process for the procurement of natural rubber latex male condoms.

The general procedures for estimating and verifying shelf-life claims are included in International Organization for Standardization (ISO) 4074:2015 (1). Requirements relating to shelf-life are specified in Clause 11 and the procedures are specified in Annex K (Determination of shelf life by real-time stability studies) and Annex L (Guidance on conducting and analysing accelerated ageing studies). Annex I (Oven treatment for condoms) specifies requirements for the equipment and procedures used to store condoms at the various temperature conditions required when conducting stability studies.

This document is intended to provide additional guidance to manufacturers on background information relating to natural rubber latex male condom shelf-life and conducting stability studies on these condoms. This information is intended to assist manufacturers in formulating and manufacturing condoms that are stable and can meet the claimed shelf-life specification when stored in adverse climatic conditions.

During the late 1980s, a great deal of attention was focused on the stability of condoms, particularly those intended for distribution in hot climates. A significant number of studies were conducted to try and understand more about how the properties of condoms change when they are stored under different climatic conditions and in different packaging materials. Some of these studies were conducted at universities and research centres. Others were conducted by condom manufacturers. The results of these studies were studied within Working Group (WG) 13 of ISO/TC 157, the ISO technical committee responsible for developing ISO 4074, the international standard for male condoms made from natural rubber latex. As a consequence of these studies, new procedures for determining the shelf-life of condoms were incorporated into the 2002 edition of ISO 4074.

Some of the new procedures were subsequently found to be of limited use for analysing stability data on natural rubber latex male condoms, particularly the methods proposed for analysing results from accelerated stability studies. Following the publication of ISO 4074:2002, the review and analysis of stability data continued within ISO/TC 157 WG 23. This led to substantial simplification and standardization of the methods used to conduct and analyse accelerated

stability studies. These new procedures, along with a number of other changes relating to real-time condom stability studies, were incorporated into the 2014 and 2015 editions of ISO 4074.

2. Storage and ageing conditions

One of the key questions considered by ISO/TC 157 WG 13, when the technical committee started reviewing condom stability, was the environmental conditions condoms might be exposed to, particularly in the hot climatic zones where they were being distributed at the time in HIV/AIDS intervention programmes. Without a full understanding of the expected storage conditions, it is not possible to choose appropriate reference temperatures for conducting stability studies and estimating shelf-life.

The pharmaceutical industry faced exactly the same problem, which led to the development of the concept of mean kinetic temperature. Establishing average temperatures over extended storage periods is relatively simple. This can be done manually by periodically measuring and recording temperatures or automatically using data loggers. However, the rates at which chemical changes occur that can affect the physical properties of products such as condoms do not usually follow a simple linear relationship with temperature. Reaction rates tend to increase exponentially with increasing temperatures. The concept of mean kinetic temperature takes the exponential changes in reaction rates into consideration and provides a method of conducting stability studies at a constant temperature whilst taking into account the impact of the long- and short-term changes in temperature that occur in real-life storage.

The International Council for Harmonisation of Technical Requirements for Pharmaceuticals for Human Use (ICH)¹ guidelines on pharmaceutical stability studies define the concept of mean kinetic temperature as “a single derived temperature which, if maintained over a defined period, would afford the same thermal challenge to a pharmaceutical product as would have been experienced over a range of both higher and lower temperatures for an equivalent defined period” (2). In other words, if a product is stored at a specified mean kinetic temperature, it will experience the same degree of thermal challenge as a product stored in the equivalent climatic zone, taking into account the normal variations in temperature that will occur over the storage period and the non-linear way in which these temperature changes will affect any chemical reactions occurring within the product.

¹ Formerly the International Conference on Harmonisation of Technical Requirements for Registration of Pharmaceuticals for Human Use, under which name the guidelines were initially published.

The concept of dividing the world into four climatic zones to facilitate the stability testing of pharmaceutical products was proposed by Paul Schumacher in 1972 (3) and Wolfgang Grimm in 1986, 1993 and 1998 (4–6). The proposal was accepted by the World Health Organization (WHO) Expert Committee on Specification for Pharmaceutical Preparations (ECSPP) in 1996, following extensive consultations (7). Table 1 summarizes the world climatic zones as defined in Annex 2, Appendix 1, of the forty-third report of the ECSPP held in Geneva in October 2008 (8).

Table 1
Proposed criteria and long-term testing conditions for defined climatic zones

Climatic Zone	Definition	Criteria: mean annual temperature/mean annual partial pressure	Testing conditions
I	Temperate	≤ 15 °C ≤ 11 hPa	(21 ± 2) °C (45 ± 5) % RH
II	Subtropical and Mediterranean	> 15 °C to 22 °C > 11 to 18 hPa	(25 ± 2) °C (60 ± 5) % RH
III	Hot and dry	> 22 °C ≤ 15 hPa	(30 ± 2) °C (35 ± 5) % RH
IVA	Hot and humid	> 22 °C > 15 to 27 hPa	(30 ± 2) °C (65 ± 5) % RH
IVB	Hot and very humid	> 22 °C > 27 hPa	(30 ± 2) °C (75 ± 5) % RH

hPa = hectopascal or millibar; RH = relative humidity.

The mean kinetic temperature of the three most extreme climatic zones – III, IVA and IVB – has been established as 30 °C with a tolerance of ± 2 °C. This temperature has therefore been adopted as the reference temperature for condom stability studies both in ISO 4074:2015 and in the WHO/UNFPA guidance for male latex condoms (9–11). The specified lower tolerance limit of –2 °C has also been adopted, but the upper tolerance limit has been increased to +5 °C to simplify temperature control requirements when conducting real-time stability studies in countries where ambient temperatures may periodically exceed 32 °C. The higher temperature limit means that stability studies are likely to be more conservative (that is, the true shelf-life, if anything, is likely to be longer than the estimated shelf-life) and the need for air-conditioning when conducting stability studies is significantly reduced.

Real-time stability studies must therefore be conducted at a temperature of (30_{-2}^{+5}) °C. Maintaining the temperature within this range is very important. Continuous temperature monitoring is strongly recommended and manufacturers conducting stability studies are advised to have contingency plans to cover equipment breakdowns and power cuts. In the event of an oven failure, for example, if the manufacturer can demonstrate that despite a resulting temperature excursion the mean kinetic temperature remained within the specified range of 28 °C to 35 °C, then the results of the study would remain valid.

3. Stability of condoms

The properties of natural rubber latex male condoms can potentially degrade through exposure to a number of environmental factors. These key factors include oxidation, ozone attack, thermal degradation at elevated temperature and exposure to light, particularly ultraviolet (UV) light. Each of these factors is considered below.

3.1 Oxidation

Being an unsaturated hydrocarbon, natural rubber is prone to oxidation if it is not protected by antioxidants and/or oxygen impermeable packaging. The mechanism of oxidation is well established and documented in the scientific literature. It is similar to that for olefins (12) but with the additional possibility of formation of cyclic peroxides due to the presence of carbon-carbon double bonds in the rubber (13).

Atmospheric oxygen reacts extremely rapidly with alkyl radicals within the rubber that can be generated by a number of mechanisms, including exposure to light, stress and heat. The resulting peroxy radicals that are formed rapidly abstract hydrogen from methylene groups adjacent to carbon-carbon double bonds in the rubber backbone, forming hydroperoxides. Also generated in this step is another alkyl radical allowing the process to repeat. Substantial repetition can occur, leading to the build-up of large numbers of hydroperoxide groups along the rubber backbone. This process is described as an autocatalytic chain reaction.

The hydroperoxide groups formed along the backbone of the rubber can subsequently decompose, for example, if exposed to heat, breaking the rubber chain (chain scission) and causing a reduction in the strength, integrity and stiffness of the rubber. Radical species generated during the hydroperoxide decomposition process can lead to further oxidation. Depending on conditions, decomposition of the hydroperoxides can also lead to further cross-linking, causing hardening of the rubber.

Since vulcanized natural rubber latex products contain sulfur cross-links, oxidation of these cross-links can also occur either directly by interaction with oxygen or by reaction with the hydroperoxides formed during oxidation of the hydrocarbon rubber backbone. Depending on the length of the sulfur cross-links and the storage conditions, decomposition of the sulfur cross-links can lead to the formation of sulfenic acids. These are powerful antioxidants and are capable of limiting the extent of oxidation that occurs (14, 15).

In practice, condoms are usually hermetically sealed in aluminium foil laminate packages (almost exclusively in the case of condoms intended for public sector distribution). This type of packaging prevents oxygen reaching the condoms, thereby protecting against oxidation. In 1996, Free et al. (16) demonstrated, using gas chromatography, that oxygen levels in aluminium foil laminate packages containing condoms dropped to around 1.6% within a few months and the rate of decline in burst pressure was substantially slower at 45 °C than for the same condoms in plastic packaging.

During manufacture prior to packaging, however, the condoms are exposed to atmospheric oxygen and some oxidation is possible. The longer the condoms are stored before packaging the more oxidation can occur, with a build-up of hydroperoxides in the rubber that could shorten the subsequent shelf-life of the product. To minimize the risks from hydroperoxide formation, the WHO/UNFPA specification limits the storage time for bulk condoms prior to packaging to six months.

To protect the condoms against oxidation, manufacturers usually add antioxidants. There are two broad types of antioxidants: those that block the autoxidative chain reaction (sometimes called radical scavengers) and those that safely decompose the resulting hydroperoxides (peroxide decomposers). The most common examples of the former are the hindered phenolic antioxidants such as Irganox 2246 and Wingstay L. These compounds have labile hydrogen atoms that can be easily abstracted by alkoxy radicals, stopping the further propagation of radical species. The resulting free radicals formed are stabilized by delocalization of the free electron and do not react with oxygen.

The other type of antioxidants are peroxide decomposers. These compounds commonly contain sulfur, for example, thioethers and thioesters, and work by safely reducing the hydroperoxides formed by autoxidation. The dithiocarbamate accelerators typically used in latex formulations are very effective peroxide decomposers. Combinations of radical scavengers and peroxide decomposers can be a lot more effective than each type of antioxidant in isolation (synergism) since they work through different mechanisms. The combination of the phenolic antioxidants that are added to the latex compounds during manufacture and the residual dithiocarbamates from vulcanization can produce very powerful antioxidant effects.

Phenolic antioxidants are typically added to latex condom formulations at the rate of 0.5 to 2 parts per hundred of dry rubber (phr). Some are available as premilled dispersions and can simply be added to the latex. If purchased in solid form, antioxidants need to be dispersed in water using suitable dispersing agents and milled to an acceptable particle size. Since residual dithiocarbamate levels vary depending upon the latex formulation, prevulcanization conditions and condom manufacturing and processing conditions, their levels can vary significantly from manufacturer to manufacturer. The extent to which the benefits of synergism between the phenolic antioxidant and any residual accelerators can improve the oxidative stability of condoms is largely unexplored but is likely to be highly variable depending on a range of factors that affect the levels of residual dithiocarbamates in the condom. It is worth noting that Free et al. (16) reported very significant differences in the rates of degradation of unpackaged condoms from different manufacturers.

3.2 Ozone

Ozone is an extremely reactive molecule. It is one of the most powerful oxidizing agents known (far stronger than oxygen). Ozone can react extremely quickly with the carbon-carbon double bonds in natural rubber, initially forming ozonides, which, being unstable, can then break down causing chain scission. The rate of reaction depends both on the concentration of ozone and the amount of stress the rubber is under. Typically, ozone attack on rubber causes cracks to appear. The extent and rate of growth of the cracks depends on how stressed the rubber is. Ozone levels tend to be higher in heavily industrialized areas due to air pollution. Certain emissions, such as nitrogen oxides and volatile organic compounds, can interact with sunlight to promote the formation of ozone locally.

Protecting rubber against ozone is usually achieved by adding waxes that “bloom” to the surface, thereby providing a sacrificial coating that “mops up” any ozone present before the rubber is damaged. It is not usual practice to add antiozonant waxes to condom formulations (though they are added to some latex glove formulations). Adequate protection against ozone is usually achieved by keeping bulk condoms covered during storage before packaging. Once lubricated and packed, the condoms are very effectively protected against ozone.

3.3 Light

It is widely acknowledged within the condom industry that exposure of condoms to light, particularly UV light and light from fluorescent tubes, can initiate the degradation of unprotected condoms. It is common practice to store bulk condoms in black plastic bags to minimize exposure to light during manufacturing operations. ISO 4074:2015 specifies that the individual container

or consumer package, or both, shall be opaque to light. If condoms are intended to be supplied only in individual containers, the individual containers shall be opaque (Clause 15.1).

3.4 Thermal stability

Although there is now a reasonable level of understanding about how the physical properties of condoms change over time when stored at different temperatures in anaerobic conditions (that is, in aluminium foil laminate packages), the chemical processes responsible for these changes are still poorly understood. The results of a pilot study investigating changes in cross-link density and cross-link chain length were presented at the Latex and Synthetic Polymer Dispersions Conference, Amsterdam, 2010 (17).

The results indicated that statistically significant increases in the density of short-chain monosulfidic and disulfidic cross-links and decreases in the density of long-chain polysulfidic cross-links occurred after 28 days at 70 °C and 120 days at 50 °C. Total cross-link density also decreased when the condoms were stored at 70 °C for 28 days.

Potentially, these changes in cross-link type and density could explain the changes in properties seen in condoms. For example, the decrease in total cross-link density at 70 °C should reduce the stiffness (modulus) of the rubber with a consequential decrease in burst pressure and a small increase in burst volume, as was observed. The changes in cross-link length at relatively constant total cross-link density seen at 50 °C might be expected to lead to a “tighter” network structure, which could explain the reduction in burst volume that was observed at this temperature.

3.5 Continuing vulcanization

Freshly dipped latex condoms may not necessarily be fully vulcanized. There is strong evidence that some condoms continue to vulcanize for quite long periods after manufacture. Evidence for this includes the sharp drop in burst volume and an increase in burst pressure that is sometimes seen when relatively fresh condoms are aged at 70 °C for seven days. These changes can confound the outcome of stability studies, leading to erroneous conclusions about the stability of the condoms concerned. When conducting stability studies, it is therefore advisable to store condoms for a period of at least six weeks from the time of dipping before starting the study. This additional time permits most of the residual vulcanization to be completed and the cross-link network within the rubber to approach equilibrium. Time should also be allowed after packaging to permit the lubricant to migrate into the rolled condom. Typically, this can take a week or two, depending on the lubricant viscosity and dusting powder used.

4. Overview of methods determining the shelf-life of condoms

The methods of assessing the shelf-life of latex condoms have been researched in considerable detail by ISO/TC 157 WG 13. In addition, a number of independent researchers have conducted comparative real-time and accelerated studies. Most notable is the research undertaken by Dr M.C. Bó of the Instituto Nacional de Tecnología, Rio de Janeiro, Brazil (18).

All of these studies have involved ageing condoms at different temperatures and comparing how the changes in temperature affect the burst properties over time. The following general trends are usually seen.

- At 70 °C, the burst pressure properties of condoms tend to decline more rapidly than the burst volume properties. Estimates of shelf-life are most likely to be limited by failure of the condoms to meet minimum burst pressure requirements. Burst volume behaviour can vary considerably depending upon the manufacturer but it often remains relatively constant, or even increases initially, before slowly declining. Accelerated stability studies at 70 °C therefore tend to overestimate the decline in burst pressures and underestimate the decline in burst volumes that occur over extended periods of real-time ageing at 30 °C.
- At 30 °C, which is the reference temperature for real-time stability studies, burst volumes tend to decline more rapidly than burst pressures. The shelf-life of the product is more likely to be limited by failure to meet the acceptable quality limit (AQL) requirements for burst volume rather than burst pressure.
- The early phases of stability studies can be misleading, since fresh condoms can undergo changes in burst properties resulting from further vulcanization or maturation of the network structure within the rubber. Often, this can result in an initial fall in burst volume and a rise in burst pressure.
- The Arrhenius relationship, which correlates changes in the rate of chemical reactions with temperature, can often be applied to burst pressure changes occurring at temperatures above 50 °C but not necessarily to burst volume changes. Even when the Arrhenius relationship is found to apply to burst volume data, the activation energy differs from that determined using burst pressure data. These factors, coupled with the different behaviour patterns observed in burst property trends at low and high temperatures, make the methods described in Annex K of ISO 4074:2002 difficult to apply

and potentially unreliable. The Arrhenius relationship may be useful when conducting stability studies on male and female condoms made from synthetic materials but it does not appear to be helpful when it comes to analysing stability data on natural rubber latex male condoms. Because of this method of estimating product, shelf-life based on the Arrhenius relationship, as described for example in ISO 11346 (Rubber, vulcanized or thermoplastic – Estimation of life-time and maximum temperature of use), are not considered in this document.

5. Determination of shelf-life according to ISO 4074:2015

The procedures for determining the shelf-life of a condom are specified in Clause 11 of ISO 4074:2015. The maximum permitted claimed shelf-life is five years from the date of manufacture. The date of manufacture can be the date of dipping or the date of packaging the condoms into their individual sealed containers, depending upon the procedures specified by the manufacturer. The date of manufacture is not permitted to be more than two years from the date of dipping. The WHO/UNFPA specification for male latex condoms, however, limits the maximum storage time for unpackaged condoms to six months from the date of dipping. The date of manufacture permitted by the WHO/UNFPA specification cannot therefore be more than six months from the date of dipping.

The unpackaged condoms must be stored under controlled conditions, as specified by the manufacturer, between dipping and packaging. The procedures for validating the storage conditions and the maximum storage period must be documented. The stored condoms must be protected from exposure to excessive temperature, light, ozone and any other factor that could affect the shelf-life of the packaged condoms.

When conducting stability studies, the condoms used must have been stored for the maximum permitted period between dipping and packaging under the conditions specified in the manufacturer's documentation. Although the WHO/UNFPA specification limits the maximum storage period to six months, manufacturers may use data from studies where the condoms have been stored for longer periods. This is to prevent unnecessary repetition of the stability studies. The six-month maximum storage period, however, still applies to condoms intended for procurement by UNFPA and other public sector agencies, even if the stability studies used to determine the shelf-life of the products concerned were completed using condoms with longer bulk storage periods.

There are essentially three elements to the stability requirement specified in ISO 4074:2015:

- i. The manufacturer is required to confirm that the condoms meet the minimum stability requirements of ISO 4074:2015 (Clause 11.2). This requires testing samples of condoms from three lots initially after conditioning for (168 ± 2) hours at (70 ± 2) °C and after conditioning for (90 ± 1) days at (50 ± 2) °C. In all cases, the condoms must comply with the requirements for burst properties specified in Clause 10 of the standard “Freedom from holes and visible defects”, as specified in Clauses 12 and 13, and “Package integrity”, as specified in Clause 14.
- ii. The shelf-life of the product is determined by conducting a real-time stability study according to Clause 11.3 and Annex K of ISO 4074:2015 at a temperature of (30^{+5}_{-2}) °C extending for the fully claimed shelf-life period. The study must confirm that the product conforms with the burst properties specified in Clause 10 of the standard “Freedom from holes and visible defects”, as specified in Clauses 12 and 13, and “Package integrity”, as specified in Clause 14. Pending completion of the real-time stability study, manufacturers may place the product on the market based on a provisional shelf-life determined in an accelerated stability study completed according to Clause 11.4 of the standard. The real-time shelf-life study must be started before the product can be marketed.
- iii. A provisional shelf-life for the product can be determined in an accelerated stability study conducted according to Clause 11.4 and Annex L of the standard. The specified method given in Clause L.2 is much simpler and easier to use than the procedure previously described in the 2002 edition of ISO 4074. It is based on the simple premise that after conditioning the condoms at (50 ± 2) °C, the following provisional shelf-life claims may be made, assuming that the condoms conform to the requirement for burst properties specified in Clause 10 of the standard “Freedom from holes and visible defects”, as specified in Clause 12, and “Package integrity”, as specified in Clause 14, at the end of each period:
 - a shelf-life of two years after a period of 90 days
 - a shelf-life of three years after a period of 120 days
 - a shelf-life of five years after a period of 180 days.

An alternative procedure is given in Clause L.3 for “Determining the shelf-life of a condom when a control condom is available”, which is also included in Annex L. The shelf-life of the control condom must have been confirmed in a real-time study conducted according to Annex K. The alternative procedure is more complicated but does have the advantage that it may be possible to identify

a set of ageing conditions that will permit a provisional shelf-life of five years to be established in less than 180 days.

The Clause L.3 procedure is conducted in two stages. First, the ageing characteristics of samples of the test and control condoms are compared by monitoring the burst properties of the condoms after conditioning for different times at selected temperatures. Based on the outcome of this study, a set of ageing conditions (time and temperature) is selected. The selected conditions must be such that significant changes in the burst properties of the control condoms are observed. A further stability study is conducted on three randomly selected lots of test condoms using the selected set of conditions. If, after the conditioning period, all three lots conform to the requirements for burst properties, freedom from holes and package integrity, then the provisional shelf-life can be assumed to be equal to that for the control condom.

Full details of how to conduct the real-time stability study are included in Annex K of ISO 4074:2015, and details on how to conduct the accelerated study are included in Annex L. These procedures are summarized in Appendix 1 to this guidance document. Additional practical guidance is given in the following section.

6. Practical guidance

As stated above, full details of how to conduct the stability studies are given in ISO 4074:2015. The following guidance provides additional information to supplement the procedures described in the standard.

6.1 Selection of condoms

A minimum of three lots of each type of condom to be tested should be selected from normal production. The lots should be randomly selected from a period of stable production.

All the selected lots must have been stored for the maximum permitted bulk storage time prior to starting the study. UNFPA limits this period to six months but results from lots stored for longer periods are acceptable.

All elements of the stability study (that is, testing for minimum stability), the real-time study and the accelerated study should be done on the same lots. This permits the results to be compared across all of the studies.

6.2 Samples and storage

It is important to calculate the total number of samples required for the study and to include additional condoms as spares. The spares should be sufficient to permit samples to be replaced during testing if required (for example, if it is

determined that a condom has a hole in it during the burst test). There should also be sufficient spares to allow for some of the testing to be repeated (for example, if anomalous results are obtained at one of the time points). The spare condoms shall be subjected to exactly the same treatment as the test condoms.

The condoms should be retested at the start of the study to obtain the initial values for analysis. It is not recommended to rely on the quality control or quality assurance results at the time of manufacture. The properties of the condoms may change between the date of manufacture and the start of the study.

The larger sample sizes specified in Annex B of ISO 4074:2015 are recommended. These sample sizes provide more confidence in the results and are less prone to random sampling errors causing the acceptance numbers to be exceeded when the condoms are, in fact, in compliance. As a minimum, the sample sizes given in Annex A of ISO 4074:2015 must be used, except when otherwise instructed in the relevant annex.

The requirements specified in Annex I of ISO 4074:2015 should be followed for storage conditions. The temperatures should be monitored regularly and recorded. Ideally, monitoring should be done on a continuous basis. The temperatures must remain within the specified tolerances. Adequate space should be left between the samples to maintain good airflow and even temperature distribution. It is strongly recommended that a documented action plan be in place, including such contingencies as a breakdown of the stability ovens or chambers or a power cut.

During the stability study, samples should be tested at regular intervals, as recommended in Annex K, Clause K.2.4 of ISO 4074:2015. This is to provide an early warning should the shelf-life prove to be shorter than the provisional shelf-life estimated from the accelerated stability studies. The intermediate results also provide information about the ageing profile of the condoms over time.

6.3 Testing

After conditioning, the packages shall be kept at (25 ± 5) °C until tested. This allows time for the condoms to come to equilibrium with the test temperature. The condoms shall be tested within 96 hours but not sooner than 12 hours after conditioning.

Before starting testing, it is very important to make sure that certain testing equipment is calibrated and working correctly. The technicians conducting the tests must be properly trained and the training records must be kept up to date.

Full details of testing conditions must be recorded and all results must be correctly captured.

6.4 Reporting

Interim reports should be maintained, each being updated as new results become available. Any trends should be monitored as the study progresses, for example, by plotting the results for average burst volumes and pressures over time, together with the standard deviations and number of nonconforming condoms. The reports should include statistical analyses; for example, for burst properties, t-tests or analysis of variance (ANOVA) can be used to compare results between lots and over time to determine if the differences are statistically significant. Fisher exact test or the chi-square test can be used to determine if any changes in the numbers of nonconforming condoms between lots and over time are statistically significant. Linear and non-linear regression analyses can be used to determine trends and extrapolate results to the end of study.

Monitoring the lower one-sided 98.5% limits of the confidence intervals for burst volumes and pressures gives a good indication as to when the numbers of nonconforming condoms are likely to exceed the acceptance numbers. These limits can be calculated from the mean and standard deviations of the burst results using the appropriate t-values for the sample sizes tested. Ideally, the lower 98.5% one-sided limits of the confidence intervals for burst volume should remain above 20 litres and burst pressures above 1.1 kilopascal (kPa) for condoms with mid-body widths in the range 50–56 millimetres. For condoms in different width ranges, the lower 98.5% one-sided limits of the confidence intervals for burst volumes should remain above about 10% of the specified limit in ISO 4074:2015 for the relevant mid-body width of the condoms.

Details about the information to be included in stability reports are given in Clause 16 of ISO 4074:2015 and in the specific annexes referring to stability studies, Annexes K and L. In addition, stability reports, both interim and final, should include full details about the condoms being tested, including lot numbers, date of manufacture (ideally both dipping and packaging), condom type and details about any secondary packaging used in the studies. Full details about the ageing conditions should be included in the report, including any deviations in temperature control. Conclusions about the shelf-life estimates for the products shall be included in the reports, including any methods used to analyse the results and the outcome of any statistical analyses.

References

1. ISO 4074:2015. Natural rubber latex male condoms – Requirements and test methods. Geneva: International Organization for Standardization; 2015.
2. ICH Q1A (R2): Stability testing of new drug substances and products. International Conference on Harmonisation of Technical Requirements for Registration of Pharmaceuticals for Human Use; 2003.

3. Schumacher P. Über eine für die Haltbarkeit von Arzneimitteln maßgebliche Klimaeinteilung [The impact of climate classification on the stability of medicines]. *Pharmazeutische Industrie*. 1972;34:481–3.
4. Grimm W. Storage conditions for stability testing (part 2). *Drugs Made in Germany*. 1986;29:39.
5. Grimm W. Storage conditions for stability testing in the EC, Japan and USA, the most important market for drug products. *Drug Development and Industrial Pharmacy*. 1993;19(20):2795–830.
6. Grimm W. Extension of the International Conference on Harmonization tripartite guideline for stability testing of new drug substances and products to countries of climate zones III and IV. *Drug Development and Industrial Pharmacy*. 1998;24(4):313–25.
7. Guidelines for stability testing of pharmaceutical products containing well established drug substances in conventional dosage forms. In: WHO Expert Committee on Specifications for Pharmaceutical Preparations: thirty-fourth report. WHO Technical Report Series No. 863, Annex 5. Geneva: World Health Organization; 1996.
8. Stability testing of active pharmaceutical ingredients and finished pharmaceutical products. Appendix 1: Long-term stability testing conditions as identified by WHO Member States. In: WHO Expert Committee on Specifications for Pharmaceutical Preparations: forty-third report. WHO Technical Report Series No. 953, Annex 2. Geneva: World Health Organization; 2009.
9. World Health Organization/United Nations Population Fund recommendations for condom storage and shipping temperatures. In: WHO Expert Committee on Specifications for Pharmaceutical Preparations: fifty-fifth report. WHO Technical Report Series No. 1033, Annex 5. Geneva: World Health Organization; 2021.
10. World Health Organization/United Nations Population Fund guidance on testing of male latex condoms. In: WHO Expert Committee on Specifications for Pharmaceutical Preparations: fifty-fifth report. WHO Technical Report Series No. 1033, Annex 6. Geneva: World Health Organization; 2021.
11. World Health Organization/United Nations Population Fund guidance on conducting post-market surveillance of condoms. In: WHO Expert Committee on Specifications for Pharmaceutical Preparations: fifty-fifth report. WHO Technical Report Series No. 1033, Annex 7. Geneva: World Health Organization; 2021.
12. Bolland JL, Gee G. Kinetic studies in the chemistry of rubber and related materials. Part 3: Thermochemistry and mechanism of olefin oxidation. *Trans Faraday Soc*. 1946;42:244.
13. Bolland JL, Hughs H. The primary thermal oxidation product of squalene. *J Chem Soc*. 1949;492.
14. Scott G. Peroxidolytic antioxidants: sulphur antioxidants and auto-synergistic stabilisers based on alkyl and aryl sulphides. In: Scott G, editor. *Developments in polymer stabilisation*, volume 6. London: Applied Science Publishing; 1983.
15. Percy EJ. A radiochemical study of the oxidation of thiosulphinates and their effects on free radical chain processes. PhD Thesis, London University, 1964.
16. Free MJ, Srisamang V, Vail J, Mercer D, Kotz R, Marlowe DE. Latex rubber condoms: predicting and extending shelf life. *Contraception*. 1996;53:221–9.
17. Potter WD. A pilot study to investigate methods of assessing the chemical changes occurring in latex condoms aged under different conditions. Paper presented at sixth Latex and Synthetic Polymer Dispersions Conference, Amsterdam, 23–24 March 2010. Smithers Rapra Technology Ltd: 2010.
18. Bó MC, Gerofi JP, Visconte LLY, Nunes RCR. Prediction of shelf life of natural rubber male condoms: a necessity. *Polymer Testing*. 2007;26(3):306–14.

Appendix 1

Summary procedures for conducting stability studies

1. Minimum stability testing

When conducting the minimum stability test, follow the procedure in ISO 4074:2015, Clause 11.2. Condition the condoms for (168 ± 2) hours at (70 ± 2) °C and (90 ± 1) days at (50 ± 2) °C using the procedures specified in ISO 4074:2015, Annex I. Before testing, condition the sample for a minimum of 12 hours but not more than 96 hours at (25 ± 5) °C. Test the condoms for burst properties, freedom from holes and visible defects (including visibly open packaging) and package integrity. In addition, inspect the condoms and packaging for any signs of discoloration and visible defects, and the condoms for odour and ease of unrolling. Finally, confirm whether or not the condoms conform to the relevant requirements specified in ISO 4074:2015.

2. Accelerated stability study

When conducting an accelerated stability study, follow the procedures in ISO 4074:2015, Clause 11.4 and Annex L. Annex L is informative (that is, it does not have to be followed exactly) but deviations should only be made if there is a very good reason to depart from the specified procedures and must be justified. If there is a suitable control condom with a shelf-life already determined by a full real-time stability study, then the procedure described in Clause L.3 can be followed. However, this procedure is more complicated than the simpler procedure described in Clause L.2 when no control condom is available.

Accelerated stability study when no control condom is available (Annex L.2)

Condition the condoms at (50 ± 2) °C using the procedures specified in ISO 4074:2015, Annex I. Remove the samples for testing after specified time periods (90, 120 and 180 days). Before testing, condition the sample for a minimum of 12 hours but not more than 96 hours at (25 ± 5) °C. Test the condoms for burst properties, freedom from holes and visible defects (including visible open seals) and package integrity. In addition, inspect the condoms and packaging for any signs of discoloration, and the condoms for odour and ease of unrolling. Assess conformance with ISO 4074:2015 requirements.

Accelerated stability study with control condom (Annex L.3)

Select the required number of condoms, including spares, from a minimum of three production lots of test condoms and a minimum of two production lots

of control condoms. Test a minimum of 32 condoms per lot, per temperature and conditioning time period. A minimum of two temperatures and five time points at the selected temperatures are recommended. Condition the condoms using the procedures specified in ISO 4074:2015, Annex I. Before testing, condition the sample for a minimum of 12 hours but not more than 96 hours at $(25 \pm 5) ^\circ\text{C}$. Test the condoms for burst properties. Compare the changes in burst properties for test and control condoms and choose a set of accelerated storage conditions (time and temperature) that results in a significant change in the burst properties of the control condoms.

After determining the set of accelerated storage conditions, select condoms from three production lots and condition them at the selected temperature using the procedures specified in ISO 4074:2015, Annex I. Before testing, condition the sample for a minimum of 12 hours but not more than 96 hours at $(25 \pm 5) ^\circ\text{C}$. Test the condoms for burst properties, freedom from holes and visible defects (including visible open seals) and package integrity. In addition, inspect the condoms and packaging for any signs of discoloration and visible defects, and the condoms for odour and ease of unrolling. Assess conformance with ISO 4074:2015 requirements.

3. Real-time stability study

Follow the procedures in ISO 4074:2015, Clause 11.3 and Annex K. This annex is normative; the specified procedures should be used as written and should not be changed.

Determine the total numbers of samples required, including spares, allowing for the following:

- testing at the end of the study for burst properties, freedom from holes and visible defects (including visibly open seals) and package integrity, preferably using the sample sizes specified in Annex B of ISO 4074:2015, but at least the sample sizes specified in Annex A;
- monitoring of burst properties during the study (32 or 125 condoms per test).

Condition the condoms at $(30_{-2}^{+5}) ^\circ\text{C}$ using the procedures specified in ISO 4074:2015, Annex I, or in a controlled environment at $(30_{-2}^{+5}) ^\circ\text{C}$. Remove samples for monitoring at regular intervals (one year or less). Before testing, condition the sample for a minimum of 12 hours but not more than 96 hours at $(25 \pm 5) ^\circ\text{C}$. Test the condoms for burst properties. Assess whether or not it is necessary to terminate the real-time study early. Continue to condition the condoms for the required shelf-life period (maximum of five years) unless the decision is taken to terminate the study early. After the full shelf-life period has been reached, remove the condoms for testing. Before testing, condition the

sample for a minimum of 12 hours but not more than 96 hours at $(25 \pm 5) ^\circ\text{C}$. Test the condoms for burst properties, freedom from holes and visible defects (including visible open seals) and package integrity. In addition, inspect the condoms and packaging for any signs of discoloration and visible defects, as well as odour and ease of unrolling. Assess conformance with ISO 4074:2015 requirements.

Annex 10

WHO/UNFPA technical specification for TCU380A intrauterine device

Contents

Abbreviations	334
1. Introduction	335
2. Glossary	338
3. General requirements	340
4. Finished product requirements	348
5. Performance requirements	351
6. Packaging, labelling and information requirements	353
7. Laboratory test methods	360
7.1 Breaking strength	360
7.2 Flexibility test	361
7.3 Copper collar retention force	361
7.4 Flange displacement force	363
7.5 Memory test	364
7.6 Sealed pouch peel strength requirements	364
7.7 Biocompatibility evaluation	365
8. Sample sizes and acceptance criteria for testing	366
8.1 Sample sizes and acceptance criteria for WHO/UNFPA prequalification testing	366
8.2 Samples sizes and acceptance criteria for continuing series of lots	366
8.3 Sample sizes and acceptance criteria for isolated lots	367
References	373
Appendix 1 IUD technical drawings	374
Appendix 2 Guidance for bioburden control and terminal sterilization	381
Appendix 3 Guidance for stability studies	389
Appendix 4 Application of the Arrhenius equation to accelerated ageing data	400

Abbreviations

ABS	acrylonitrile-butadiene-styrene
AQL	acceptance quality limit
cm	centimetre
g	gram
GMP	good management practices
HDPE	high-density polyethylene
Hg	mercury
ICH	International Council for Harmonisation of Technical Requirements for Pharmaceuticals for Human Use
ISO	International Organization for Standardization
IUD	intrauterine device
kGy	kilogray
kJ	kilojoule
kPa	kilopascal
LDPE	low-density polyethylene
mm	millimetre
MPa	megapascal
N	newton
NDA	new drug application
OFE	oxygen-free electronic
PP	polypropylene
ppm	parts per million
RH	relative humidity
SAL	sterility assurance level
UNFPA	United Nations Population Fund
UNS	unified numbering system
USP	United States Pharmacopeia
WHO	World Health Organization

1. Introduction

This annex contains the World Health Organization (WHO) and United Nations Population Fund (UNFPA) technical specification for TCU380A intrauterine device (IUD), which is suitable for bulk procurement of the TCU380A IUD for use in public sector programmes for family planning.

The WHO/UNFPA technical specification for TCU380A IUD covers the specific TCU380A IUD design and differentiates it from other generic copper-bearing IUDs. It also includes requirements for manufacturers for each of the individual components. A specification is a detailed and unambiguous statement of the requirements and describes the general design, performance, labelling and packaging requirements for the product and the methods of verification. A specification is part of the supply contract and will generally be attached to the bidding documents and forms.

The WHO/UNFPA technical specification for TCU380A IUD is based on the requirements for copper-bearing IUDs defined by the International Organization for Standardization (ISO) in ISO 7439:¹ Copper-bearing contraceptive intrauterine devices – Requirements and tests (1). This standard specifies the generic requirements for copper-bearing IUDs and the test methods that are used to assess conformance with these requirements. Specific requirements for the TCU380A IUD are based on the Population Council New Drug Application (NDA) 18-680 (Copper T model TCU380A) (2). The standard ISO 7439 is referred to generically throughout this specification; unless otherwise specified, it should be assumed that the most recent edition of this internationally agreed standard applies.

The requirements in this specification are divided into the following three sections:

- **General requirements** specify the safety of constituent materials and other characteristics, such as shelf-life, materials, product and component dimensions, storage, biocompatibility, sterility and method of sterilization. These requirements are normally assessed by material and process validation, including testing, where appropriate, by the manufacturer. Revalidation is required following any significant change to the sourcing of raw materials or changes in the manufacturing processes. The general requirements detailed in the *TCu380A intrauterine contraceptive device: WHO/UNFPA technical specification and prequalification guidance 2016* (3) may not be changed by the purchaser. Conformance with the general

¹ When references to standards are undated the most recent edition of the standard applies.

requirements is verified during prequalification. The prequalification process aims to ensure that characteristics of the product do not change on a lot-by-lot basis.

- **Performance requirements** specify the essential performance attributes of the TCu380A IUD, established in accordance with ISO 7439 and the Population Council NDA. These must be verified on a lot-by-lot basis by the manufacturer and may be verified by the purchaser on a lot-by-lot basis. Performance requirements detailed in the *WHO/UNFPA technical specification and prequalification guidance 2016 (3)* may not be changed.
- **Packaging and labelling requirements** are detailed in the *WHO/UNFPA technical specification and prequalification guidance 2016 (3)* and may not be changed. Continuous film packaging combined with terminal radiation is preferred, as it reduces the risk of tarnishing. Additional labelling may be specified based on programmatic needs.

The WHO/UNFPA technical specification is based on:

- international standard ISO 7439 (1);
- Population Council NDA 18-680 (Copper T model TCu380A intrauterine contraceptive) (2);
- a literature review of the available evidence;
- the recommendations of the WHO/UNFPA IUD Technical Review Committee (November 2006, August 2008 and September 2013);
- feedback from participants attending the WHO/UNFPA workshops to introduce the TCu380A IUD specification, prequalification and procurement procedures, conducted in Bangkok, Thailand, in January 2010 and New Delhi, India, in February 2014.

Where appropriate, reference is made to the current edition and corrigenda of the published international standard ISO 7439: Copper-bearing contraceptive intrauterine devices – Requirements and tests (1).

The WHO/UNFPA technical specification, if used in conjunction with the WHO/UNFPA Prequalification Programme and procurement procedure, will ensure that a quality-assured product is purchased and distributed to the end user.

The TCu380A IUD consists of a T-shaped frame made from low-density polyethylene with barium sulfate added for X-ray opacity (Fig. 1), with a plastic ball at the bottom of the vertical stem to guard against cervical penetration. The IUD has solid copper collars on each of its two horizontal arms. Each of these collars has a surface area of 35 square millimetres (mm²). Copper wire with a surface area of 310 mm² is wound tightly around the vertical stem giving a total

surface area of 380 mm² of copper, as indicated in the name of the device. A pigmented polyethylene filament is tied in a knot through a small hole in the ball to provide two equal-length threads as a means to locate and remove the device. The device is packed in an individual pouch and subjected to post-packaging sterilization.

Tarnishing is a natural phenomenon for copper and does not affect the performance of the IUD. However, significant tarnishing of copper during storage may not be aesthetically acceptable. The use of continuous film packaging, which is suitable for gamma radiation sterilization, helps to reduce the problem of tarnishing.

Fig. 1
TCu380A IUD

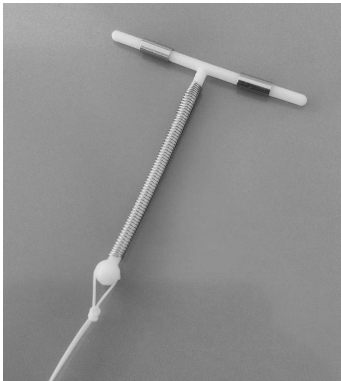

In order to insert the device into the uterus, an insertion tube is used. The insertion tube keeps the TCu380A IUD correctly positioned within the uterus while the insertion rod is removed. The movable plastic flange is positioned on the insertion tube to control the depth of insertion and to locate the IUD correctly within the uterus during insertion.

Other devices to assist the process of insertion may also be provided, such as an arm-folding device, a uterine sound, sterile gloves or sterile swabs. When considering the design and choice of materials for these components, manufacturers should take into account the function of the devices, the type and duration of exposure to the body and the effect of sterilization.

Purchasers should assess the functionality, safety and effectiveness of any assist devices, including their potential effect on the IUD prior to purchase.

For IUDs specifically manufactured and labelled for postpartum insertion, deviations from the specifications regarding length of string and dimensions of the inserter are permitted if they can be clinically justified.

Copper-bearing IUDs are classified under European Medical Device Directive 93/42/EEC (as amended) as Class III medical devices with ancillary medicinal substances (4). The regulation of medical devices in Europe has been in transition with Medical Device Regulation EU 2017/745 (5), which came fully into force on 26 May 2020. The clinical studies detailed in the technical basis paper have all been conducted using the TCu380A IUD complying with the Population Council specification submitted in NDA 18-680, which requires a minimum copper purity of 99.99%. These studies have demonstrated that the TCu380A IUD based on this specification is both effective and safe.

2. Glossary

acceptance number. The highest number of nonconforming units (failures) allowed in a specific test from a selected sample.

acceptance quality limit (AQL). The quality level that is the worst tolerable process average when a continuing series of lots is submitted for acceptance sampling (ISO 2859-1).

Note: Manufacturers should be consistently achieving a process average that is better than the AQL.

batch. A term sometimes used in place of “lot” (see definition of “lot”). WHO recommends that the term “lot” be used when referring to medical devices. “Batch” can also refer to a quantity of individual raw materials.

bioburden. The population of microorganisms on a raw material, component, product, packaging or equipment.

CE mark. On medical product packaging, a mark certifying that the product conforms to the essential requirements of European Medical Device Directive 93/42/EEC.

critical defect. A defect that might affect the safety, acceptability or effectiveness of the product is classified as a critical defect, causing the device to be rejected.

expiry date. In the context of IUD manufacture, the expiry date is the date after which raw materials, components, and so on, are no longer considered acceptable for manufacturing IUDs.

good manufacturing practice. A code of practice aimed at ensuring that product is consistently manufactured to the required standard.

insert before date (referred to in previous editions of the specification as “latest insertion date”). The date after which the device should not be inserted into the

uterus. (Occasionally, the term “expiry date” is used, but this can be confused with the latest date by which the device has to be removed from the uterus. The use of “expiry date” is therefore discouraged in this context.)

inspection level. The degree of examination of the lot, as specified in ISO 2859-1. The higher the inspection level, the more samples that will be tested and, hence, the lower the risk of faulty products reaching the consumer.

lot. A quantity of raw materials, components or IUDs made at essentially the same time and having a single lot identification code or number. Clear lot identification and recording are required to permit effective product recall in the event of a quality problem with the device. The definition of a lot of manufactured IUDs is given in section 3 on general requirements.

lot number or code. A unique identifying alphanumeric code assigned to a lot.

non-critical defect. A defect that might affect the acceptability of the product, causing the device to be rejected at the time of insertion, but is not expected to affect the safety or effectiveness of the device.

package. The film–film or film–Tyvek peel pouch in which the IUD is sealed after manufacture and sterilization.

prequalification. The steps taken by the buyer to verify a manufacturer’s suitability to provide IUDs of the required quality. The WHO/UNFPA Prequalification Programme includes periodic assessment of manufacturing dossiers, testing of samples and manufacturer inspection.

process average. The percentage of nonconforming IUDs over a defined time period or quantity of production. It is calculated for each requirement detailed in the WHO/UNFPA TCu380A IUD technical specification by dividing the number of nonconforming IUDs by the total number of IUDs tested. Ideally, the process average for a specific attribute should not be greater than half the specified AQL.

random sample. A sample of IUDs drawn randomly from a lot for testing purposes.

sampling plan. A specific plan that indicates the number of units (IUDs) from each lot that are to be inspected (sample size) and the associated criteria for determining the acceptability of the lot (acceptance and rejection numbers).

shelf-life. The period of time after manufacture that the product is considered suitable for insertion, stated as the insert before date (previously, latest insertion date) on the pack.

specification. A detailed statement of a product’s requirements as established by the buyer. Usually, a specification is based on an established standard.

standard. A detailed statement of the minimum acceptance requirements, as established by a national or international regulatory body.

summary of technical information. New document format introduced to replace the product dossier and site master file.

unified numbering system (UNS). An alloy designation of the National Bureau of Standards.

3. General requirements

The general requirements specified in this section shall not change from lot to lot. Conformance with these requirements is assessed during prequalification and also in case of doubts by the purchaser as to whether or not the product complies with the specification. Conformance may need to be assessed if any significant changes are made in the selection and sourcing of materials or the manufacturing procedures. As per prequalification requirements, manufacturers shall inform UNFPA of any changes that impact conformance with general requirements. The general requirements are set out in Table 1, classified by category.

Table 1
General requirements (to be evaluated during prequalification)

Requirements by category	Specifications
1.1 Lot definition	
Requirement	A lot is a homogeneous collection of IUDs made under essentially identical manufacturing conditions using the same lots of raw materials: low-density polyethylene (LDPE) compound, high-density polyethylene (HDPE) compound for thread, copper for wire and collars, and individual pouches and individual pouch material that are subjected to sterilization in the same sterilization cycle and assigned a unique number before release. Clear lot identification and recording are required to permit effective product recall in the event of a quality problem with the device.
1.2 Date of manufacture	
Date of manufacture requirement	The date of manufacture of a lot is the month and year in which the IUDs were sealed in the primary package for terminal sterilization. Sterilization shall be conducted in accordance with part 1.5 of this table.

Table 1 *continued*

Requirements by category	Specifications
1.3 Materials	
T frame requirements	<p>The T frame shall be made from LDPE, free of stabilizers, having a minimum tensile strength of 13 megapascals (MPa) (ASTM D638 and ISO 527-2), using a crosshead speed of 50 mm/min and a type 1 specimen bar) and a 2% secant flexural modulus in the range 133.5 MPa to 180.6 MPa (ASTM D790).</p> <p>The LDPE shall be blended with 15% to 25% precipitated barium sulfate USP (United States Pharmacopeia) with a particle size of 95% less than 10 micron.</p> <p>The barium sulfate content of the frame material shall be determined according to the relevant clause of ISO 7439. See also the biocompatibility requirements for compounded polymer, below.</p>
Copper wire requirements	<p>The wire shall be made from oxygen-free electronic (OFE) 99.99% pure copper meeting the National Bureau of Standards designation UNS C10100. There shall be no coating on the wire.</p>
Copper collars requirements	<p>The copper collars shall be made from half-hard temper, seamless copper tube made from OFE 99.99% pure copper meeting the National Bureau of Standards designation UNS C10100. There shall be no coating on the collars.</p>
Thread requirements	<p>The thread shall be a monofilament made from HDPE, free of stabilizers, with sufficient tensile strength to meet the specified thread breaking force requirement greater than 9.5 newtons. A material with a minimum tensile strength (ASTM D638 and ISO 527-2) of 28 MPa is recommended.</p> <p>The thread polymer shall be compounded with 0.4% up to 1.0% by weight rutile titanium dioxide (USP and European Pharmacopeia).</p> <p>See also the biocompatibility requirements for compounded polymer, below.</p>
Insertion tube requirements	<p>The insertion tube shall be made from HDPE food contact grade.</p>

Table 1 *continued*

Requirements by category	Specifications
Insertion rod requirements	The rod shall be made from food contact grade radiation-stable acrylonitrile-butadiene-styrene (ABS) polymer or food contact grade radiation-stabilized polypropylene (PP). Optionally, the insertion rod may be pigmented.
Positioning flange requirements	The flange shall be made from a polymer with adequate radiation stability to permit sterilization without any significant change in properties, including flange displacement force. Optionally, the flange may be pigmented.
Biocompatibility requirements	<p>The compounded T frame polymer (LDPE plus barium sulfate) and compounded thread, as an assembly or separately, shall be evaluated for biological safety in accordance with ISO 10993-1 requirements for devices principally contacting tissue and tissue fluid contact devices intended for permanent contact. Specifically, the following is required:</p> <ul style="list-style-type: none"> • evaluation for genotoxicity according to ISO 10993-3; • evaluation for cytotoxicity according to ISO 10993-5; • evaluation for local effects after implantation according to ISO 10993-6; • evaluation for irritation and delayed-type hypersensitivity according to ISO 10993-10; • evaluation for subacute and subchronic toxicity according to ISO 10993-11. <p>Testing must be performed by a laboratory that is accredited to ISO 17025, with IUD testing included in the scope of accreditation.</p> <p>For a specific material, it is only necessary to carry out the assessment of biological safety once. The evaluation shall be repeated if there is a significant change to the materials; for example, if the grade or supplier is changed.</p>

Table 1 *continued*

Requirements by category	Specifications
	<p>Where a manufacturer sources components or materials from another IUD manufacturer, it is not necessary to conduct a further biocompatibility assessment on those components or materials, provided that the manufacturer supplying the components or materials has conducted a biological safety evaluation and has made the results of that evaluation available to the manufacturer using the components or materials. The manufacturer purchasing the components or materials shall maintain a technical file containing the biocompatibility information provided with the components or materials.</p> <p>Manufacturers may continue to use their current grades of LDPE and HDPE if these are consistent with the Population Council specification without conducting the biocompatibility evaluation on the T frame compound with barium sulfate or thread compound with titanium dioxide.</p> <p>It is required that all biological safety tests in accordance with ISO 10993 parts 1, 3, 5, 6, 10 and 11 be conducted by laboratories accredited for these tests. Detailed requirements are provided in section 7.7.</p>
Material procurement and control requirements	<p>Manufacturers are responsible for ensuring all operations, including those undertaken by subcontractors, such as material storage, compounding of the frame and thread materials and moulding, are done to acceptable standards, as specified below. There should be adequate control procedures and documentation to ensure and demonstrate conformance in accordance with ISO 13485.</p> <p>These procedures should ensure that batches of compounded materials (T frame, thread materials) and moulding and extrusion of the components are not contaminated by any extraneous impurities during processing operations.</p> <p>Where lubricants are used in moulding and extrusion, the grades shall be food grade or suitable for medical device manufacture.</p> <p>Materials and components should be stored in a manner in which they are protected from light and high humidity. The storage conditions shall ensure conformance with bioburden levels specified for the product.</p>

Table 1 *continued*

Requirements by category	Specifications
	<p>If appropriate, the copper components or other components should be cleaned prior to assembly.</p> <p>Manufacturers shall introduce procedures to monitor and control the degree of tarnish and rough edges on the copper components.</p> <p>The maximum storage period before retesting of the raw material is required for the frame polymer and the thread is three years from the date of manufacture when stored at temperatures below 30 °C and two years when stored at temperatures between 30 °C and 35 °C.</p> <p>Provided the breaking force of the frame material exceeds 13 MPa (which may be determined by testing moulded frames) and the breaking force of the thread exceeds 9.5 newtons (N), then the materials may be used for a further three years when stored at temperatures below 30 °C and two years when stored at temperatures between 30 °C and 35 °C.</p> <p>Every new lot of compounded frame material (LDPE plus barium sulfate) and thread material (HDPE plus titanium dioxide) shall be subjected to in vitro cytotoxicity testing in accordance with ISO 10993-5: Biological evaluation of medical devices. For tests for in vitro cytotoxicity, see section 7.7.</p> <p>The cytotoxic response shall not be worse than that recorded for the compounded material when originally evaluated for biological safety according to the requirements of ISO 10993-1.</p>
Packaging	IUDs shall be packed in film–film pouches for better protection and to improve confirmation of package integrity, unless sterilization is by ethylene oxide.
Material processing requirement	The recycling of injection moulded reclaim material for the T frame and the thread is not permitted.
1.4 Shelf-life, maximum in situ time and stability	
Stability studies requirements	<p>Claims about shelf-life shall be supported by real-time stability data collected in accordance with Appendix 3. Accelerated ageing stability studies may be submitted pending the completion of real-time studies.</p> <p>Guidance on conducting stability studies is given in Appendix 3, on guidance for stability studies.</p>

Table 1 *continued*

Requirements by category	Specifications
Insert before date requirements	The insert before date is the maximum permitted shelf-life for storage of the device prior to insertion and is normally five years. By agreement with the purchaser, the shelf-life may be extended to seven years subject to satisfactory real-time stability data being available and reviewed for the full seven years for storage in climatic zone IVB, 30 °C/75% relative humidity (RH). The stability data shall include package integrity testing substantiating maintenance of sterility.
Maximum in situ time	Based on efficacy and safety evidence, the maximum in situ time is 12 years.
1.5 Bioburden control and terminal sterilization	
Sterilization and method requirements	<p>The TCu380A IUD shall be supplied sterile in a sealed primary pack (pouch) together with the insertion tube, the insertion rod and the positioning flange.</p> <p>Sterilization shall be by radiation according to ISO 11137 series, or by ethylene oxide according to ISO 11135 series, and standards normatively referenced therein.</p> <p>Radiation sterilization is preferred, to allow the use of continuous polymer film packaging materials.</p> <p>The sterilization shall be completed within 30 days of sealing the finished device in the pouch.</p>
Sterility assurance level requirements	The sterilization assurance level shall be 1×10^{-6} .
Residual ethylene oxide levels requirements	<p>If ethylene oxide sterilization is used, then residual ethylene oxide levels shall not exceed 10 parts per million (ppm), and ethylene chlorohydrin levels shall not exceed 20 ppm, on any individual sample when measured using a method that complies with the requirements of ISO 10993-7.</p> <p>Average residual levels across all samples tested shall not exceed 5 ppm for ethylene oxide and 10 ppm for ethylene chlorohydrin.</p> <p>Guidance on bioburden control and terminal sterilization is given in Appendix 2.</p>

Table 1 *continued*

Requirements by category	Specifications
1.6 Component specifications	
T frame	<p>Length of horizontal arms (total length of both arms): (32 ± 0.5) mm.</p> <p>Length of vertical stem: (36 ± 0.5) mm.</p> <p>Diameter of horizontal arm: (1.6 ± 0.1) mm.</p> <p>Diameter of vertical stem: (1.5 ± 0.1) mm.</p> <p>Optionally, a hole for anchoring an end of the copper wire may be provided. The maximum diameter of the hole shall be 0.55 mm.</p> <p>The T piece ball (at the end of the vertical stem) shall have a diameter of (3.0 ± 0.7) mm. The junction between the ball and the vertical stem shall preferably be radiused.</p> <p>The T piece ball (at the end of the vertical stem) shall have a hole of maximum diameter 0.80 mm for securing the thread. The hole may be tapered or dumb-bell shaped.</p> <p>The junctions between the horizontal arms and the vertical stem may be radiused to prevent stress concentrations. If the junction is radiused, the radius shall be between 0.25 mm and 0.40 mm.</p> <p>Manufacturers shall confirm that introducing the radius does not lead to an increase in crush damage at the junction when the T is deformed as it is loaded into the insertion tube. This can be achieved by comparing the strength of radiused and non-radiused T frames after loading in the insertion tube. Microscopic examination should be used alongside strength testing to monitor the extent of any damage.</p> <p>A drawing of the T frame is included in Appendix 1.</p>
Copper wire	The diameter of the wire shall be (0.255 ± 0.005) mm (30 AWG, 33 ISWG).
Copper collars	<p>The internal diameter shall be (1.68 ± 0.025) mm and external diameter (2.2 ± 0.025) mm. The collars shall be (5 ± 0.15) mm in length.</p> <p>The collars shall be deburred, polished and free from sharp edges; for example, by barrel tumbling.</p> <p>A drawing of the copper collar is included in Appendix 1.</p>

Table 1 *continued*

Requirements by category	Specifications
Thread	The thread diameter shall be (0.25 ± 0.05) mm.
Insertion tube	<p>The length of the insertion tube shall be (206 ± 2) mm.</p> <p>The internal diameter of the insertion tube shall be $(3.7 + 0.2/-0.1)$ mm. This should be determined using a plug gauge.</p> <p>The outside diameter of the insertion tube shall be $(4.4 + 0.2/-0.1)$ mm.</p>
Insertion rod	<p>The length of the insertion rod shall be (190 ± 5) mm from handle brace to tip.</p> <p>The insertion rod shall be a snug fit but slide smoothly within the insertion tube and shall not trap the thread.</p> <p>It is recommended that the rod have a thickened section, spline or ridge to help retain the rod within the insertion tube.</p> <p>The diameter of the insertion rod at tip shall be (2.6 ± 0.2) mm. The rod diameter should be equal to or less than the tip diameter.</p>
Testing	<p>Preferably, the dimensions should be determined using non-contact methods, such as a projection microscope. Appropriate gauges or calipers may be used as an alternative.</p> <p>The internal diameter of insertion tube is assessed by using appropriate plug gauges.</p>
1.7 Flexibility test	
Requirement	<p>When tested according to the test method given in section 7.2, the deflection of the horizontal arm from its original position measured at the point on the arm where the load is applied shall be greater than 4.0 mm. A suitable test jig may be used to clamp the T frame and amplify the deflection of the arm, in which case the deflection on the scale shall be greater than that equivalent to a deflection of 4 mm at the point on the arm where the load is applied.</p> <p>This test must be performed on frames prior to assembly. Therefore, verification of conformance with this requirement shall be confirmed at prequalification and requalification.</p>
Testing	According to the test method given in section 7.2.

4. Finished product requirements

These requirements are assessed on finished products during prequalification or surveillance testing. They may also be used for assessing product on a lot-by-lot basis and when doing in-country testing. Testing should be based on the sampling requirements given in section 8. Finished product requirements are set out in Table. 2, classified by category.

Table. 2

Finished product requirements (to be evaluated during prequalification or surveillance testing)

Requirements by category	Specifications
2.1 T frame	
Requirements	<p>All IUDs measured in a test sample shall fall within these ranges:</p> <ul style="list-style-type: none"> • Length of horizontal arms (total length of both arms): $(32 + 1.0/-0.5)$ mm. • Length of vertical stem: $(36 + 1.0/-0.5)$ mm. • Diameter of horizontal arm: (1.6 ± 0.1) mm. The measurement should be taken between the collars. • Diameter of vertical stem where it is not covered by copper wire: (1.5 ± 0.1) mm. • The vertical stem shall terminate in a ball. The T piece ball (at the end of vertical stem) shall have a diameter of (3.0 ± 0.7) mm. The junction between the ball and the vertical stem shall preferably be radiused. • The T piece ball (at the end of vertical stem) shall have a hole for securing the thread. <p>A drawing of the T frame is included in Appendix 1.</p>
Testing	<p>Preferably the dimensions should be determined using non-contact methods such as a projection microscope. Appropriate gauges or calipers may be used as an alternative. The diameter of the horizontal arm shall be measured between the collars.</p>
2.2 Thread	
Requirements	<p>The thread shall be knotted to form two tails of approximately equal length.</p> <p>The length of each tail shall be not less than 105 mm and not greater than 125 mm.</p>

Table 2 *continued*

Requirements by category	Specifications
Testing	The length of the tails shall be measured using a calibrated rule from the base of the T piece ball.
2.3 Copper collar	
Requirements	<p>Collar position: $(5.4 + 1.3/-0.7)$ mm from the ends of the T horizontal arm. The measurement shall be taken from the ends of the arms at the edge of the radius.</p> <p>Collar weight shall be (68.7 ± 3.0) milligrams (mg).</p> <p>A drawing of the copper collars is included in Appendix 1.</p>
Testing	<p>Preferably the dimensions should be determined using non-contact methods such as a projection microscope. Appropriate gauges or calipers may be used as an alternative.</p>
2.4 Copper surface area	
Requirements	<p>The nominal surface area shall be 380 mm² with a tolerance of $\pm 10\%$ (tolerance specified in ISO 7439). Provided the copper collar and copper wire weights are within the specified limits below, the surface area will comply with the requirements of this specification and ISO 7439 tolerances.</p> <p>Collar weight shall be (68.7 ± 3.0) mg.</p> <p>Wire weight shall be (176 ± 11) mg.</p>
Testing	The weight of the wire and collars shall be determined using a balance after careful removal from the frame.
2.5 Copper wire winding	
Requirements	<p>The wire shall be wound so that it is in contact with the frame and is uniform. The proximal and distal ends of the wire must lie smoothly on the T surface and not protrude beyond the wire profile in order to prevent any chance abrasion of uterine tissue during insertion or in situ.</p> <p>The length of wire protruding from the anchoring hole (the "tag") shall not exceed 10 mm. It shall be bent to point down the vertical stem and not interfere with the position of the arms when the IUD is placed in the insertion device.</p> <p>Both single- and double-wound configurations are acceptable.</p>
Testing	By visual inspection.

Table 2 *continued*

Requirements by category	Specifications
2.6 Insertion tube	
Requirements	<p>The length of the insertion tube shall be (206 ± 2) mm.</p> <p>The internal diameter of the insertion tube shall be $(3.7 + 0.2/-0.1)$ mm.</p> <p>The outside diameter of the insertion tube shall be $(4.4 + 0.2/-0.1)$ mm.</p>
Testing	<p>The internal diameter is assessed by using an appropriate size plug or pin gauge. Measurement will need plug or pin gauges that span the specification measurement: 3.9 mm (tight or not slide in easily), 3.7 mm (go in) and 3.6 mm (tight or slide in easily).</p> <p>The outside diameter should be determined using appropriate ring gauges.</p> <p>The measurements shall be taken at three locations: two within 20 to 30 mm from either end of the tube, and one within ± 10 mm of the midpoint of the tube.</p> <p>Non-contact methods are preferred for the outside diameter.</p>
2.7 Insertion rod	
Requirements	<p>The length of the insertion rod shall be (190 ± 5) mm from handle brace to tip.</p> <p>The insertion rod shall be a snug fit but slide smoothly within the insertion tube and shall not trap the thread.</p> <p>It is recommended that the rod have a thickened section, spline or ridge, to help retain the rod within the insertion tube.</p> <p>The diameter of the insertion rod at tip shall be (2.6 ± 0.2) mm. The rod diameter should be equal to or less than the tip diameter.</p>
Testing	<p>Dimensions shall be determined using appropriate calibrated rules, gauges or calipers or non-contact techniques.</p> <p>Assess the fit of insertion rod by inspection.</p>

Table 2 *continued*

Requirements by category	Specifications
2.8 Insertion tube flange	
Requirements	The shape and dimensions of the central hole shall be such that the specified flange displacement force specification is met.
Testing	By visual inspection.

5. Performance requirements

When tested according to the relevant clause of ISO 7439 or, if appropriate, the specified test method in this document, the performance requirements of the finished product after sterilization shall conform with the requirements specified below. Verification of performance requirements shall be done as part of prequalification or surveillance testing. Testing should be based on the sampling requirements given in section 8. Performance requirements are set out in Table. 3, classified by category.

Table. 3

Performance requirements (to be evaluated during prequalification or surveillance testing)

Requirements by category	Specifications
3.1 Breaking strength	
Requirements	The breaking force of the finished product after sterilization shall be greater than 9.5 N.
Testing	According to the relevant clause of ISO 7439. Further information about testing for breaking force is given in section 7.1.
3.2 Copper collar retention force	
Requirements	The minimum force required to displace a collar on the arm shall be 6.86 N (700 g-force) when tested using a separation speed of (200 ± 20) mm/min.
Testing	According to the test method given in section 7.3.

Table 3 *continued*

Requirements by category	Specifications
3.3 Memory	
Requirements	When the finished product after sterilization is tested according to relevant clause of ISO 7439, the maximum displacement of the horizontal arms from their original position shall be not greater than 5.0 mm.
Testing	According to ISO 7439.
3.4 Thread knot	
Requirements	The knot shall be secure. An insecure thread knot is considered a defect (see part 3.7 of this table, on product defects).
Testing	By visual inspection.
3.5 Insertion rod	
Requirements	The insertion rod shall be a snug fit but slide smoothly within the insertion tube and shall not trap the thread.
Testing	By inspection.
3.6 Flange displacement force	
Requirements	The required force to achieve a steady displacement of the flange shall be between 2.0 and 9.0 N.
Testing	According to the method given in section 7.4.
3.7 Product defects	
Requirements	<p>Finished IUDs should be inspected visually for evidence of visible defects. The severity of defects may vary depending upon the level of impact they have on the safety, effectiveness and acceptability of the product. The number of pieces to be inspected are given in section 8.3. All IUDs comprising the sample shall comply with the requirements for visible defects listed below.</p> <p>Manufacturers and testing laboratories should maintain a list of these defects, with clear definitions and diagrams or photographs to assist both in the assessment of workmanship and in the resolution of any disputes. Below are listed the most common types of defects encountered.</p>

Table 3 *continued*

Requirements by category	Specifications
	<p>Defects</p> <p>Assessed by visual examination, not measurement:</p> <ul style="list-style-type: none"> • severe tarnishing of the copper collars or wire; • slight tarnishing (acceptable with the agreement of the purchaser); • missing components or empty pouch; • flash on the mould lines of the T frame; • sharp protruding edges or burrs; • unsecured or missing thread (including loose or unsecure knot); • incomplete or deformed ball; • deformed or loose collars; • improperly sealed pouches; • embedded or surface foreign particles on any component within the sealed pouch; • transfer of any printing onto the device; • insertion rod bent or distorted (acceptable at the discretion of the purchaser if still usable); • discoloration of insertion tube or rod.
Testing	By inspection of visible defects.

6. Packaging, labelling and information requirements

Packaging, labelling and information requirements are set out in Table 4, classified by category.

Table 4
Packaging, labelling and information requirements

Requirements by category	Specifications
4.1 Device	
Markings requirements	<p>The insertion tube may optionally be printed with depth gauge markings.</p> <p>Manufacturers may mark the frame of the device for identification purposes, provided it does not affect the function and safety of the product.</p>
Testing	By inspection of the product.

Table 4 *continued*

Requirements by category	Specifications
4.2 Individual pouch and insert (primary packaging)	
Packaging requirements	<p>Each TCu380A IUD shall be packed in an individual pouch. All pouches shall be sealed.</p> <p>Packaging materials shall comply with ISO 11607, Part 1. IUDs shall be packed in film–film pouches for better protection and improved confirmation of package integrity, unless sterilization is by ethylene oxide.</p> <p>If an insert is used, it should not affect the safety and performance of the device or be affected by the method of sterilization. The total bioburden of the insert and the device shall be controlled prior to sterilization, in accordance with the validated sterilization protocol.</p>
Testing	<p>Sealed pouch integrity shall be tested according to ASTM D3078 (standard test method for determination of leaks in flexible packaging by bubble emission) using a high vacuum of (24.5 ± 0.5) inches of mercury. This is equivalent to an absolute pressure of (18.4 ± 1.7) kilopascals (kPa) or a gauge reading of (622 ± 12.7) millimetres of mercury (mmHg).</p> <p>If permeable packaging material is used, sealed pouch integrity shall be tested by ASTM F1929 (standard test method for detecting seal leaks in porous medical packaging by dye penetration) using Method B (edge dip method). This method shall only be used for permeable packing materials.</p>
Sealed pouch strength requirements	The peel force shall be not less than 4.4 N and not greater than 19 N for a test sample width of 25.4 mm.
Testing	Testing shall be conducted according to ASTM F88 (standard test method for seal strength of flexible barrier materials). Details regarding the test method are included in section 7.6.

Table 4 *continued*

Requirements by category	Specifications
Labelling requirements	<p>The information shall be printed on the primary container or on an insert that is clearly visible through the primary container.</p> <p>The following information, at a minimum, should be included on the individual pouch or on an insert in the individual pouch. All labelling shall be clearly legible.</p> <ul style="list-style-type: none"> • Lot identification number. • Month and year of manufacture in a language or languages to be specified by the purchaser. The year shall be written as a four-digit number and the month as a two-digit number or abbreviation, as agreed with the buyer. • Insert before date (previously referred to as latest insertion date or expiry date). The insert before date is the date after which the product cannot be inserted in utero. The insert before date shall be printed in a language or languages to be specified by the purchaser and shall be based on the maximum product shelf-life from the date of sterilization. The year will be written as a four-digit number and the month as a two-digit number. If manufacturers choose to include the term “expiry date” on packaging, this must be in brackets below the insert below date and the meaning of expiry date must be defined. • The maximum lifetime in situ. The maximum length of time that the device can remain in utero shall be printed on the primary container. This period shall not exceed 12 years from the date of insertion. • Manufacturer’s name and registered address. • The word “Sterile” and the methods of sterilization. • The words “For single use only” or equivalent. • The phrase “Should be administered by a skilled health care provider”. • Indication that the device is a TCu380A.
Testing	By inspection of manufacturer’s documentation during inspection and visual inspection during prequalification testing and surveillance testing.

Table 4 *continued*

Requirements by category	Specifications
4.3 Consumer packaging	
Definition	A consumer package contains an individual pouch and will commonly contain branding information.
Requirements	The WHO/UNFPA TCu380A IUD technical specification contains no requirements for consumer packaging. If consumer packaging is required, then the full design of the consumer pack should be specified in accordance with the requirements of the programme.
Testing	If consumer packaging is specified, then the consumer packs should be visually inspected for conformance.
4.4 Inner boxes (secondary packaging)	
Definition	Inner boxes, sometimes referred to as secondary packaging or inner cartons, contain specified quantities of IUDs in their individual pouches.
Packaging requirements	The individual pouches shall be packed in inner boxes. The inner boxes shall be constructed of cardboard. A suitable moisture-resistant barrier on inner or outer surfaces of the boxes may be specified by the purchaser. The boxes shall be of sufficient strength and rigidity to retain their shape through every stage of the supply chain.
Labelling requirements	The inner boxes will be marked in a legible manner to describe the contents and to facilitate identification in case of subsequent query. The following information as a minimum shall be included on the inner box. All labelling shall be clearly legible. <ul style="list-style-type: none"> • Lot identification number. • Month and year of manufacture in a language or languages to be specified by the purchaser. The year shall be written as a four-digit number and the month as a two-digit number or abbreviation, as agreed with the purchaser. • Insert before date in a language or languages to be specified by the purchaser. The insert before date shall be based on the maximum product shelf-life from the date of sterilization. The year will be written as a four-digit number and the month as a two-digit number or abbreviation, as agreed with the purchaser.

Table 4 *continued*

Requirements by category	Specifications
	<ul style="list-style-type: none"> • Manufacturer's name and registered address. • Number of pieces contained in the inner box. • Instructions for shipping and handling, including the phrase "Store in a dry place away from direct sunlight and sources of heat". There is no need to specify a maximum storage temperature on the packaging. • Description of the contents as "medical devices" and indication that the devices are the TCu380A model. • Any specific labelling required by local regulations or regulations in the country to which the product is being shipped. Other information as specified by the purchaser. • Inner box markings can be specified in accordance with programme requirements.
Testing	<p>By visual inspection during prequalification testing or surveillance testing.</p> <p><i>Note:</i> Suitable packaging having the specified labelling might not be available at the time of inspection during prequalification but manufacturers should demonstrate ability to comply with inner pack labelling requirements, for example, through standard operating procedures and past samples.</p>
4.5 Exterior shipping cartons	
Definition	Exterior shipping cartons, sometime referred to as outer boxes or cartons, are the outer containers in which individual pouches within inner boxes are shipped.
Packaging requirements	<p>The inner boxes shall be packed into plastic or other waterproof lining bags, which will be placed in three-wall cartons made from weather-resistant corrugated fibreboard of sufficient strength to avoid products being damaged during shipment.</p> <p>The carton flaps shall be secured with water-resistant adhesive or with appropriate water-resistant tape. Alternatively, the cartons may be secured by plastic strapping at not less than two positions.</p>

Table 4 *continued*

Requirements by category	Specifications
	<p>Alternatively, wire-bound, cleated plywood or nailed wooden boxes are acceptable when lined with a waterproof barrier material.</p> <p>The barrier material must be sealed at the edges with waterproof tape or adhesive, and there must be no sharp protrusions inside the boxes.</p>
Labelling requirements	<p>The exterior shipping cartons will be marked in a legible manner to describe the contents and to facilitate identification in case of subsequent query.</p> <p>The following information as a minimum shall be included on the exterior shipping carton. All labelling shall be clearly legible.</p> <ul style="list-style-type: none"> • Lot identification number. • Manufacturer's name and registered address. • Month and year of manufacture in a language or languages to be specified by the purchaser. The year shall be written as a four-digit number and the month as a two-digit number or abbreviation, as agreed with the buyer. • Number of pieces contained in the shipping carton. • Insert before date in a language or languages to be specified by the purchaser. The year will be written as a four-digit number and the month as a two-digit number. • Instructions for shipping and handling, including the phrase "Store in a dry place away from direct sunlight and sources of heat". There is no need to specify a maximum storage temperature on the packaging. • Description of the contents as "medical devices". • Any specific labelling required by local regulations or regulations in the country to which the product is being shipped. • Other information as specified by the purchaser.
Testing	<p>By inspection of manufacturer's documentation during inspection and visual inspection during prequalification testing and surveillance testing.</p>

Table 4 *continued*

Requirements by category	Specifications
4.6 Packaging and labelling: visible defects	
Individual pouch and insert	<p>Individual pouches should be inspected visually for evidence of visible defects.</p> <p>Common individual pouch and insert defects include:</p> <ul style="list-style-type: none"> • discoloured film and labels; • missing or incorrect labelling information, as specified in category 4.2 above; • pouch with open or damaged seals; • unclear and not readily legible printing on individual pouch and insert.
Consumer packaging	Not specified
Inner boxes	<p>Inner boxes should be inspected visually for evidence of visible defects.</p> <p>Common inner box defects include:</p> <ul style="list-style-type: none"> • damaged boxes that may affect the integrity, quality or distribution of the IUDs inside; • empty or partially filled inner boxes; • missing or incorrect labelling information, as specified in category 4.4 above; • unclear and not readily legible printing on inner box.
Exterior shipping cartons	<p>Exterior shipping cartons should be inspected visually for evidence of visible defects.</p> <p>Common exterior shipping carton defects include:</p> <ul style="list-style-type: none"> • damaged shipping cartons that may affect the integrity, quality or distribution of the IUDs inside; • empty or partially filled exterior shipping cartons; • missing or incorrect labelling information, as specified in category 4.5 above; • unclear and not readily legible printing on exterior shipping cartons.
Testing	By inspection of visible defects.

7. Laboratory test methods

Further details of the test procedures are given in this section. These include modification to the test methods given in ISO 7439 or test methods that are specific to the TCu380A IUD.

All testing shall be performed at a temperature of $(23 \pm 2) ^\circ\text{C}$.

7.1 Breaking strength

The IUD shall be tested according to ISO 7439 with the arms of the T frame bent upward and clamped parallel to each other at a distance of (8 ± 2) mm apart, with a single tail thread clamped at a distance of 5 mm from the point of attachment to the IUD. The arms of the T frame shall be clamped by the copper collars only.

Conditioning, as specified in the relevant clause of ISO 7439, needs to be carried out only in the case of dispute.

An example of a suitable clamp for holding the device is shown in Fig.2(a), and Fig.2(b) shows the test in progress.

Fig. 2
Testing breaking strength

(a) Breaking force test clamp

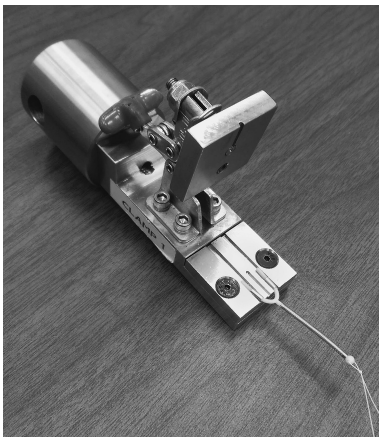

Source: FHI 360.

(b) Breaking strength test



Source: FHI 360.

7.2 Flexibility test

This test is used by the manufacturer to confirm the flexibility of the frame. A 20 gram (g) weight is applied to one of the horizontal arms of the T frame for a period of 30 seconds at a distance of 12 mm from the vertical arm. The deflection of the arm from the horizontal position is measured at the point on the arm where the load is applied.

A suitable test jig may be used to clamp the T frame and measure the amplitude of the deflection. A pivoted needle or lever may be used to amplify the deflection of the horizontal arm. A photograph of a suitable test jig is shown in Fig. 3. Technical drawings for this measurement equipment can be requested from UNFPA. If such a test jig is used, the T frame arm deflection may be converted into a scale reading using the appropriate amplification factor for the jig.

The test shall be carried out at a temperature of (23 ± 2) °C on frames that are at least 96 hours old from the time of moulding. Before testing, the T frames shall be stored for at least 6 hours at the test temperature.

Fig. 3
Flexibility apparatus

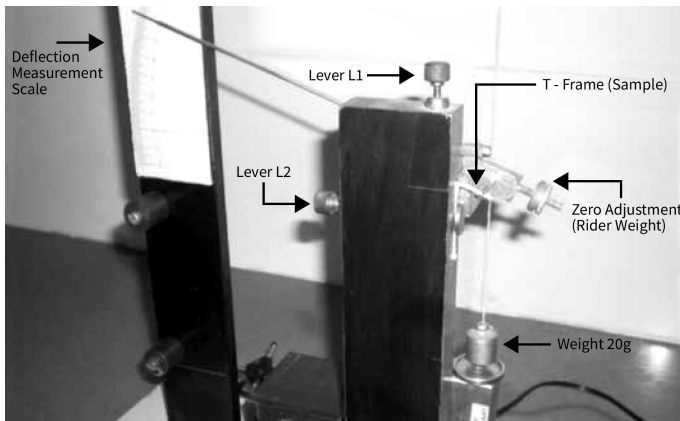

Source: Corporate Channels India Pvt. Ltd.

7.3 Copper collar retention force

Testing shall be conducted using a suitable measuring device, such as a tensile testing machine, that can measure the displacement force at a separation speed of (200 ± 20) mm/min.

During the copper collar retention force test, the device shall be clamped by the collar on one of the arms, using a suitable jig if necessary, and the opposing arm shall be gripped in the opposite clamp. The force applied to the clamped collar shall not be sufficient to crush the collar and cause it to tighten onto

the arm. This can be achieved, for example, by gripping the collar with a clamp having a groove milled with a 1.59 mm (1/16 inch) ball end mill to a depth of 1.38 mm, or about 65% of the collar diameter, to prevent crushing the collar.

Alternatively, one collar may be clamped in one jaw with sufficient force to ensure that it is partially crushed and tightened onto the arm so that there is no slippage during the test. The other collar shall be clamped lightly in the opposing jaw so that it is not crushed and tightened onto the arm. This can be achieved, for example, by using a clamp having a groove milled with a 1.59 mm (1/16 inch) ball end mill to a depth of 1.38 mm, or about 65% of the collar diameter, to prevent crushing the collar.

Pictures of suitable apparatus for the copper collar retention force test are presented in Fig. 4(a–c).

Fig. 4
Apparatus for copper collar retention force test

(a) Copper collar retention force: clamp

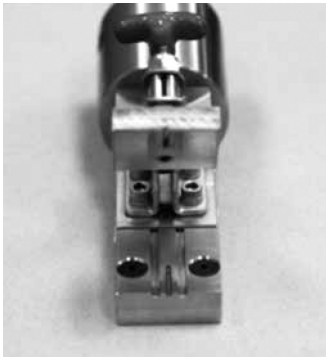

(b) Copper collar retention force: test set-up



(c) Copper collar retention force: IUD in clamp



Source: FHI 360.

7.4 Flange displacement force

Testing shall be conducted using suitable measuring equipment, such as a tensile testing machine, that can measure the displacement force at a displacement speed of (200 ± 20) mm/min. A suitable test rig will be required to clamp the tube and apply a displacement force to the flange. An appropriate load cell should be used, such as a 50 N or 10 N load cell.

The displacement force should be assessed after any initial “set” is overcome. Record the highest force measured once the flange is moving.

To remove set, the flange should be moved over a distance of 1 centimetre (cm) along the tube in the same direction as it will be moved during the test. This can be done manually or by using a suitable jig. The displacement force shall be measured immediately after removal of the set.

An example of a suitable jig for removing the set is shown in Fig. 5(a), and the flange force test set-up is shown in Fig. 5(b).

Fig. 5
Testing flange displacement force

(a) Flange force set removal jig

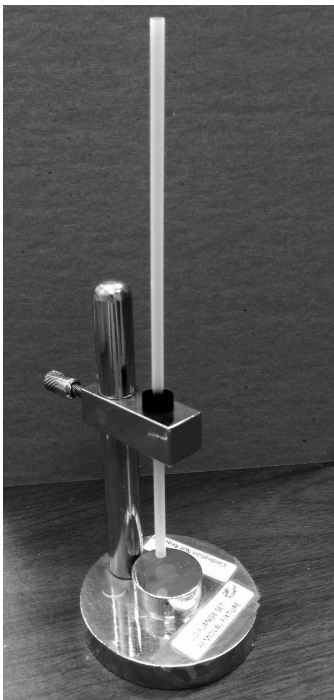

Source: FHI 360.

(b) Flange force test set-up



Source: FHI 360.

7.5 Memory test

The finished product after sterilization shall be tested according to the relevant clause of ISO 7439 for recovery after deformation (viscoelastic property). The maximum displacement of the arms from their original position shall be not greater than 5.0 mm. Fig. 6 shows an example of how the displacement is measured.

Fig. 6
Memory test

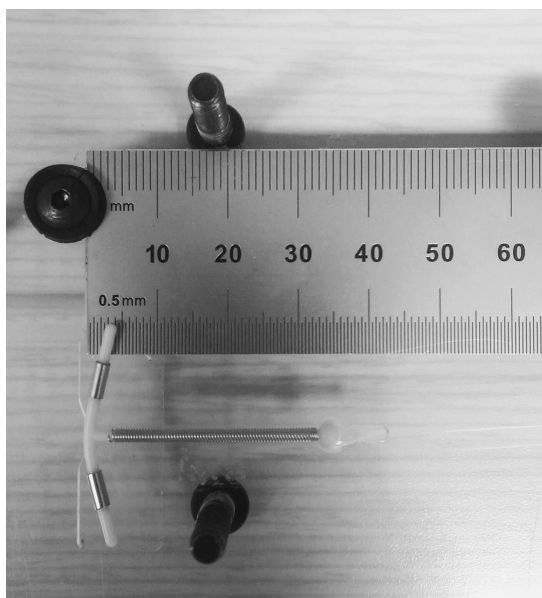

Source: FHI 360.

7.6 Sealed pouch peel strength requirements

Carefully open at the end of the individual pouch as directed on the insert. This end normally has an angled shaped seal. Limit the extent of opening so it is just sufficient to be able to withdraw the pouch contents. Carefully remove the contents of the pouch.

Cut two strip samples using a 25.4 mm wide die. If a 25.4 mm wide die is not available, a die within the range of 20–40 mm may be used and the minimum and maximum peel strength requirements, as specified in category 4.2 of Table. 4, shall be adjusted on a pro rata basis. The first sample shall be cut across at the approximate midpoint of the individual pouch. The second sample shall be cut parallel to the long axis of the individual package incorporating the intact end seal at the opposite end to where the pouch has been opened.

For the sample cut across the individual pouch, one of the sealed ends shall be cut off leaving a V-shaped sample, as indicated in Fig. 7.

Fig. 7
Sealed pouch peel strength: test set-up

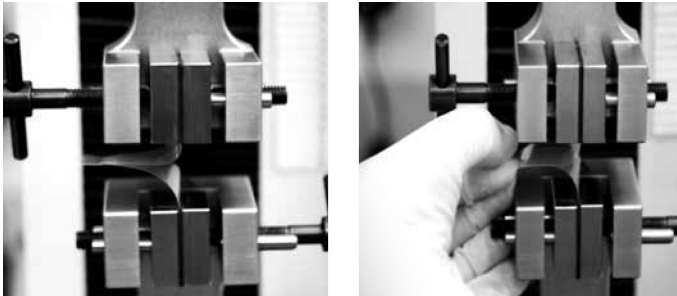

Source: FHI 360.

The seal strength of the end seal and side seal samples shall then be determined according to the following methods:

- If the packaging is made from two equally flexible materials, Technique B of ASTM F88 shall be used (sample supported at an angle of 90° by hand).
- If a rigid material is used as part of the pack, for example, a moulded tray, then Technique C of ASTM F88 shall be used (sample supported at an angle of 180°).

7.7 Biocompatibility evaluation

Biocompatibility evaluation shall be conducted according to the methods described in the relevant part of ISO 10993. When testing is necessary, it is recommended that extracts are used to assess biocompatibility. Suitable extraction media may include culture medium with or without serum, serum and saline, depending upon the specific test that is being conducted. Extraction shall be conducted according to ISO 10993 12. The recommended extraction conditions are (72 ± 2) hours at (50 ± 2) °C. The recommended ratio of sample to extraction medium is 0.2 g per 1 mm. It is permissible to test either the compounded polymers or the moulded frame and thread. If the finished products are used for this testing, the copper wire and collars should be removed to prevent the risk of false positive results.

Some regulatory authorities may require additional testing or certain tests to also be done using non-polar extraction media, such as pharmacopoeial

grades of cottonseed or sesame oil. Specific test requirements should be confirmed locally before undertaking any testing.

For cytotoxicity testing, it is recommended that quantitative tests are used. A suitable test can be selected from the following annexes of ISO 10993-5:

- Annex A: Neutral red uptake (NRU) cytotoxicity test
- Annex B: Colony formation cytotoxicity test
- Annex C: MTT cytotoxicity test
- Annex D: XTT cytotoxicity test.

Results should be reported as IC₅₀ or Viab % values, as appropriate.

Laboratories with accreditation for these tests shall be used for all biocompatibility testing. The results shall be interpreted by a suitably qualified toxicologist or other suitable expert.

8. Sample sizes and acceptance criteria for testing

Significant changes have been made to the sample sizes and acceptance criteria compared with the 2010 specification. Given the characteristics of the products, the nature of the manufacturing processes and, for the most part, the relatively small lot sizes used by many manufacturers, fixed sample sizes and specific acceptance criteria have been adopted rather than specified inspection levels and AQLs. Sample sizes vary depending upon the purpose of testing being carried out.

8.1 Sample sizes and acceptance criteria for WHO/UNFPA prequalification testing

Sample sizes and acceptance criteria for prequalification testing are given in Table. 5. These sample sizes are intended to provide a very high level of confidence that the product conforms to the specification requirements. They also take account of difficulties often encountered by inspectors and sampling agencies when trying to take samples for prequalification testing.

8.2 Samples sizes and acceptance criteria for continuing series of lots

Sample sizes and acceptance criteria for continuing series of lots are given in Table. 6. These sample sizes are applicable when a series of at least five lots is being assessed. They can be used, for example, by purchasers who wish to conduct preshipment or confirmatory testing.

They are also recommended when in-country testing is carried out, and can also be used by manufacturers for assessing the conformance of production lots.

For any requirement, there shall be no nonconforming units in the sample tested. If at any time two out of five (or fewer than five) consecutive lots are found to be nonconforming on any specific requirement, then the number of samples used to assess the conformity for future lots shall be increased to the number given in brackets for that specific requirement (tightened inspection). The sample sizes given in the brackets shall continue to be used until five consecutive lots have been found to be acceptable for that requirement (that is, change from tightened inspection to normal inspection). The sample sizes for continuing series of lots specified in Table. 6 apply only when five or more lots are being assessed.

In addition to using the sample sizes and acceptance criteria given in Table. 6 for assessing production lots, it is recommended that manufacturers adopt statistical process control procedures, such as the use of control charts, to ensure that their products conform to the specification. It is also strongly recommended that manufacturers conduct periodic process capability studies to confirm that their processes are operating within acceptable tolerances.

8.3 Sample sizes and acceptance criteria for isolated lots

Sample sizes and acceptance criteria for assessing the conformity of fewer than five lots are given in Table. 6. These sample sizes are recommended for surveillance testing where only a limited number of lots are assessed. They can also be used for confirmatory or in-country testing on small shipments and for testing retained or returned samples from lots following complaints or in-use failures. The sample sizes have been increased to provide a higher level of confidence in deciding whether or not an individual lot conforms to the specification requirements.

A total sample of 600 IUD pieces taken from between 1 and 20 lots, depending upon the production plan of the manufacturer, is required for testing. This includes a small contingency (20) in case there are problems with any of the samples or tests. Please note the total sample size for prequalification is 600 pieces, irrespective of the number of lots the sample is taken from.

UNFPA will determine the sampling plan following review of production plans supplied by the manufacturer.

The IUDs contained in the packages subjected to the package seal integrity and peel strength tests can be used for testing. All dimensional measurements can be conducted on the same IUD samples.

Table 5
Samples sizes and acceptance criteria for WHO/UNFPA prequalification testing of the TCu380A IUD

Requirement	Prequalification		Category (see Tables. 1–4)
	Sample size from all lots	Maximum permitted nonconforming units per sample	
Frame dimensions			
Length of horizontal arms	50	2	2.1
Length of vertical stem			
Diameter of horizontal arm			
Diameter of vertical stem			
T piece ball diameter			
Thread length	50	2	2.2
Copper collars			
Position	50	2	2.3
Weight			
Copper collar retention force			
Copper wire			
Copper wire weight	125	2	2.4
Copper wire winding	50	2	2.5
Insertion tube			
Insertion tube dimensions	50	2	2.6
Length			
Internal diameter			
External diameter			
Insertion rod dimensions			
Length	50	2	2.7
Diameter at tip			
Fit in insertion tube			

Table 5 *continued*

Requirement	Prequalification		Category (see Tables. 1–4)
	Sample size from all lots	Maximum permitted nonconforming units per sample	
Finished IUD after sterilization			
Breaking strength	200	5	3.1
Memory	80	3	3.3
Flange displacement force	50	2	3.6
Packaging			
Sealed pouch integrity	500	0	4.2
Package pouch peel strength			
End seal	80	2	5.2
Side seal	80	2	
Product defects			
Defects (including knot security)	125	3	3.7
Packaging defects (inner boxes and exterior shipping cartons, to be evaluated by inspection company)			
Individual pouch	These will be evaluated by the inspectors or by a sampling or inspection agency Assessment will be based on ability to comply with requirements		4.6
Inner box (if consignment includes less than 13 inner boxes, inspect all boxes)			4.6
Exterior shipping carton (if consignment includes less than 13 exterior shipping cartons, inspect all boxes)			4.6

Table 6
Sample sizes and acceptance criteria for testing of continuing series of lots and isolated lots of the TCu380A IUD

Requirement	Continuing series of lots		Isolated lots (surveillance testing)		Category (see Tables. 1–4)
	Sample size for normal (tightened) inspection	Maximum permitted nonconforming units per sample	Sample size (pieces)	Maximum permitted nonconforming units per sample	
Frame dimensions					
Length horizontal arms	8 (13)	0	32	1	2.1
Length vertical stem					
Diameter horizontal arm					
Diameter vertical stem					
T piece ball diameter					
Thread length	8 (13)	0	32	1	2.2
Copper collars					
Position	8 (13)	0	32	1	2.3
Weight					
Copper collar retention force					
Copper wire					
Copper wire weight	20 (32)	0	80	1	2.4
Copper wire winding	8 (13)	0	32	1	2.5

Table 6 *continued*

Requirement	Continuing series of lots		Isolated lots (surveillance testing)		Category (see Tables. 1–4)
	Sample size for normal (tightened) inspection	Maximum permitted nonconforming units per sample	Sample size (pieces)	Maximum permitted nonconforming units per sample	
Insertion tube					
Insertion tube dimensions	8 (13)	0	32	1	2.6
Length					
Internal diameter					
External diameter					
Insertion rod dimensions					
Length	8 (13)	0	32	1	2.7
Diameter at tip					
Fit in insertion					3.5
Tube					
Finished IUD after sterilization					
Breaking strength	13 (20)	0	50	1	3.1
Memory	8 (13)	0	32	1	3.3
Flange displacement force	8 (13)	0	32	1	3.6

Table 6 continued

Requirement	Continuing series of lots		Isolated lots (surveillance testing)		Category (see Tables. 1–4)
	Sample size for normal (tightened) inspection	Maximum permitted nonconforming units per sample	Sample size (pieces)	Maximum permitted nonconforming units per sample	
Packaging					
Sealed pouch integrity	125 (200)	0	125	0	4.2
Sealed pouch peel strength					
End seal	13 (20)	0	50	1	4.2
Side seal					
Product defects					
Defects (including knot security)	13 (20)	0	50	1 ^a	3.7
Individual pouch	13 (20)	0	13	0	4.6
Inner box (if consignment includes less than 13 inner boxes, inspect all boxes)					
Exterior shipping carton (if consignment includes less than 13 exterior shipping cartons, inspect all boxes)					

^a When testing lots that have been stored for over a year, the maximum permitted number of nonconforming units shall be raised to three for slight tarnishing and bent or distorted insertion rods.

References

1. ISO 7439:2015. Copper-bearing contraceptive intrauterine devices – Requirements and tests. Geneva: International Organization for Standardization; 2015.
2. ParaGard Copper T model TCU 380A intrauterine contraceptive. Population Council New Drug Application (NDA) 18-680, 1984.
3. TCu380A intrauterine contraceptive device: WHO/UNFPA technical specification and prequalification guidance 2016. Geneva: World Health Organization and United Nations Population Fund; 2016.
4. Guidelines relating to the application of: The Council Directive 90/385/EEC on active implantable medical devices and The Council Directive 93/42/EEC on medical devices (MEDDEV 2. 1/3 rev3, clause B.4.1). European Commission DG Enterprise and Industry; 2009.
5. Regulation (EU) 2017/745 of the European Parliament and of the Council of 5 April 2017 on medical devices, amending Directive 2001/83/EC, Regulation (EC) No. 178/2002 and Regulation (EC) No. 1223/2009 and repealing Council Directives 90/385/EEC and 93/42/EEC. European Parliament and Council of the European Union; 2017.

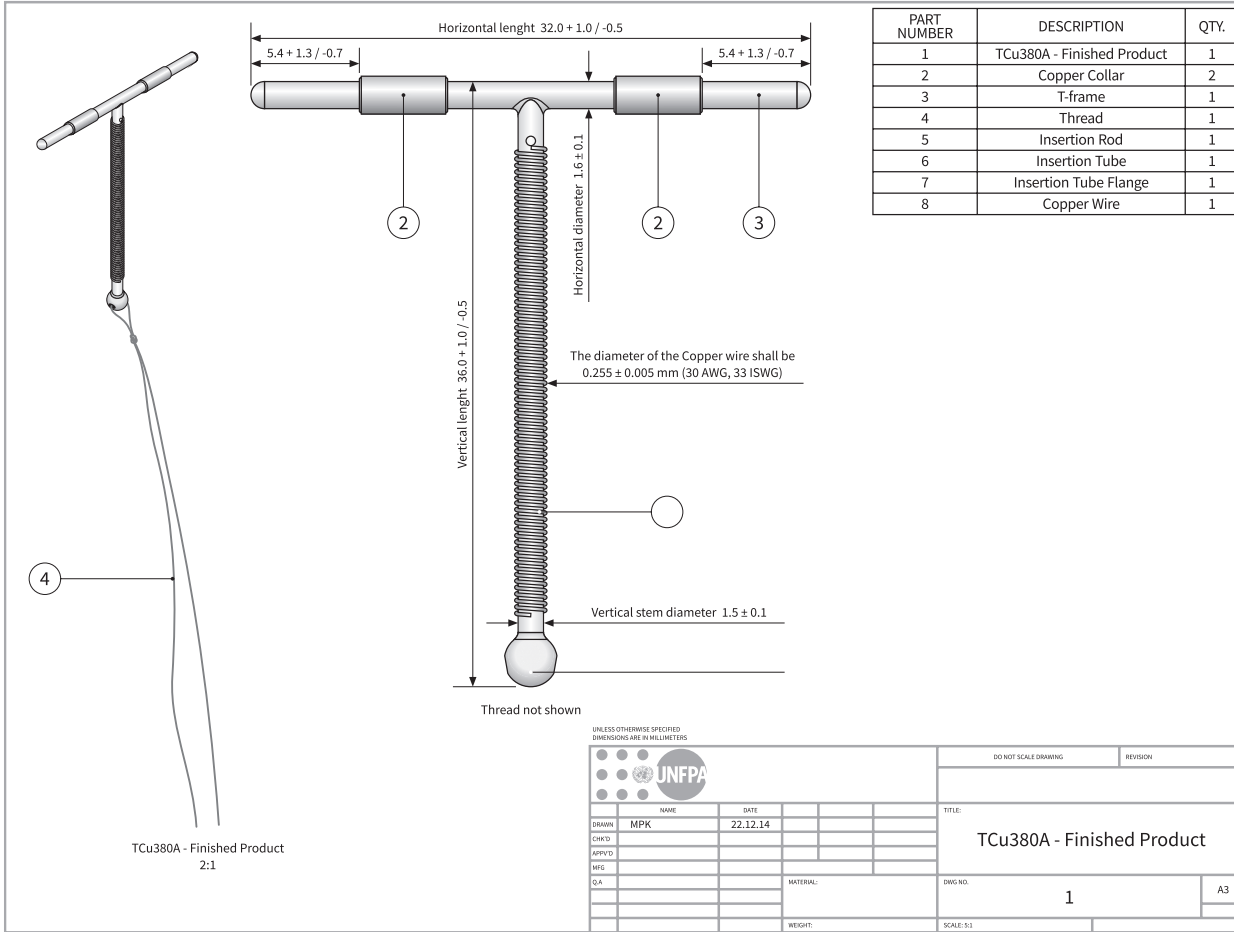

IUD technical drawings

Appendix 1

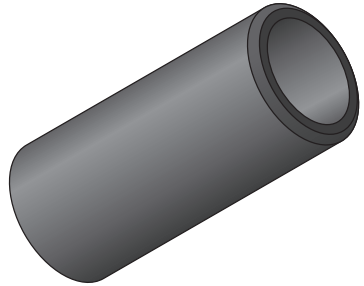
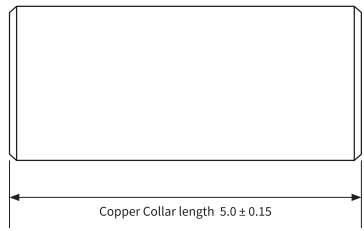
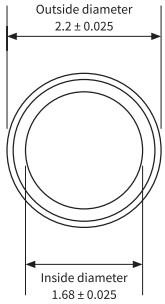

UNLESS OTHERWISE SPECIFIED
DIMENSIONS ARE IN MILLIMETERS

				DO NOT SCALE DRAWING		REVISION																																																													
<table border="1"> <thead> <tr> <th>NO.</th> <th>NAME</th> <th>DATE</th> <th></th> <th></th> <th></th> </tr> </thead> <tbody> <tr> <td>01</td> <td>MPK</td> <td>23.12.14</td> <td></td> <td></td> <td></td> </tr> <tr> <td> </td> <td> </td> <td> </td> <td> </td> <td> </td> <td> </td> </tr> <tr> <td> </td> <td> </td> <td> </td> <td> </td> <td> </td> <td> </td> </tr> <tr> <td> </td> <td> </td> <td> </td> <td> </td> <td> </td> <td> </td> </tr> <tr> <td> </td> <td> </td> <td> </td> <td> </td> <td> </td> <td> </td> </tr> <tr> <td> </td> <td> </td> <td> </td> <td> </td> <td> </td> <td> </td> </tr> <tr> <td> </td> <td> </td> <td> </td> <td> </td> <td> </td> <td> </td> </tr> <tr> <td> </td> <td> </td> <td> </td> <td> </td> <td> </td> <td> </td> </tr> <tr> <td> </td> <td> </td> <td> </td> <td> </td> <td> </td> <td> </td> </tr> </tbody> </table>				NO.	NAME	DATE				01	MPK	23.12.14																																																				TITLE:		Copper Collar	
NO.	NAME	DATE																																																																	
01	MPK	23.12.14																																																																	
MATERIAL:				DRWG. NO.		2																																																													
WEIGHT:				SCALE:		A3																																																													

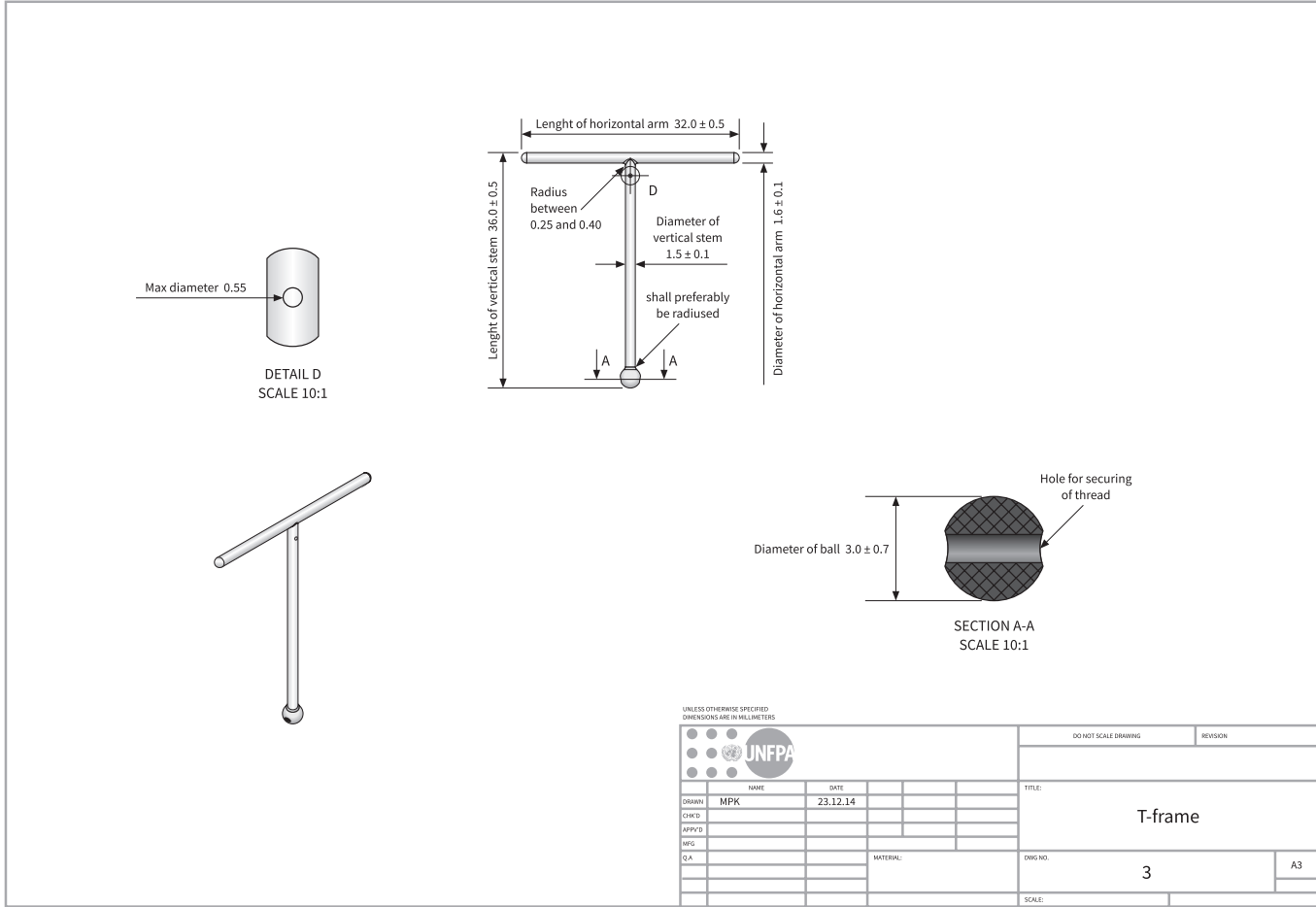

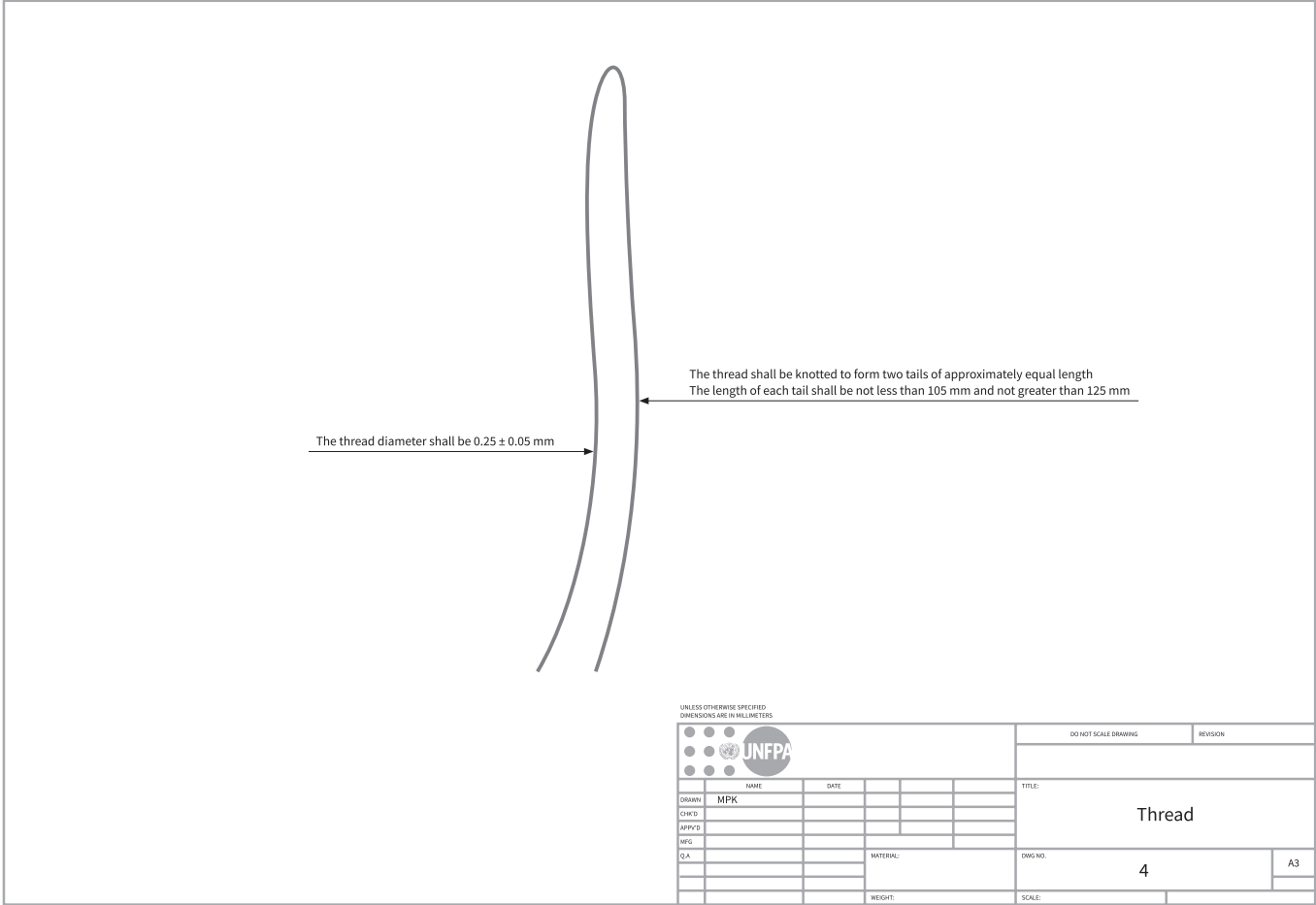

UNLESS OTHERWISE SPECIFIED
DIMENSIONS ARE IN MILLIMETERS

				DO NOT SCALE DRAWING		REVISION																																										
<table border="1"> <thead> <tr> <th>ORGAN</th> <th>NAME</th> <th>DATE</th> <th></th> <th></th> <th></th> <th></th> </tr> </thead> <tbody> <tr> <td>MPK</td> <td></td> <td></td> <td></td> <td></td> <td></td> <td></td> </tr> <tr> <td>CHK'D</td> <td></td> <td></td> <td></td> <td></td> <td></td> <td></td> </tr> <tr> <td>APP'VD</td> <td></td> <td></td> <td></td> <td></td> <td></td> <td></td> </tr> <tr> <td>DES.</td> <td></td> <td></td> <td></td> <td></td> <td></td> <td></td> </tr> <tr> <td>QA</td> <td></td> <td></td> <td></td> <td></td> <td></td> <td></td> </tr> </tbody> </table>				ORGAN	NAME	DATE					MPK							CHK'D							APP'VD							DES.							QA							TITLE:		Thread
ORGAN	NAME	DATE																																														
MPK																																																
CHK'D																																																
APP'VD																																																
DES.																																																
QA																																																
				MATERIAL:		DRWG. NO. 4																																										
				WEIGHT:			A3																																									
				SCALE:																																												

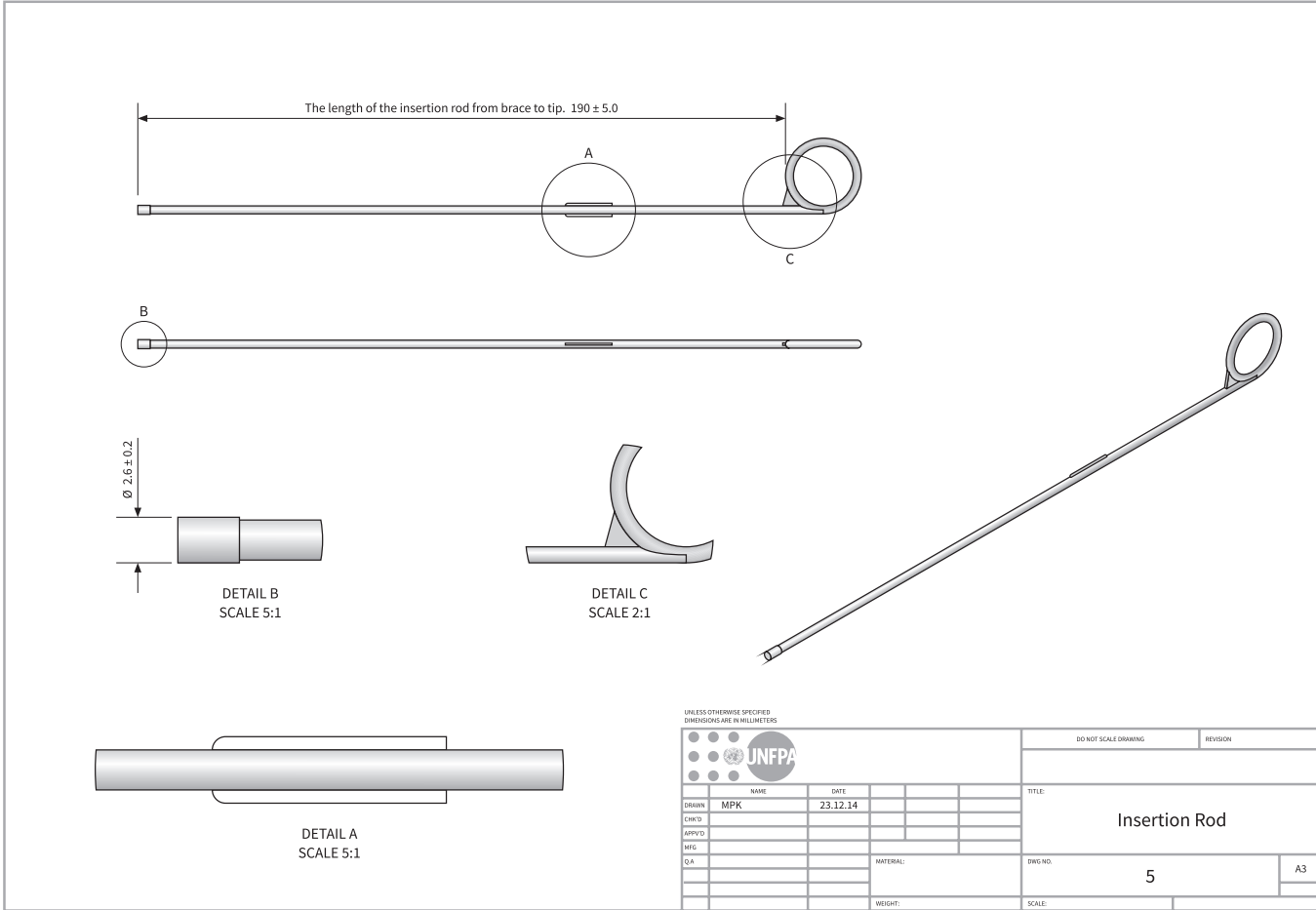

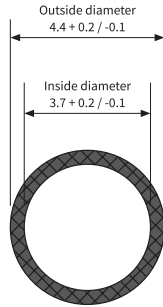
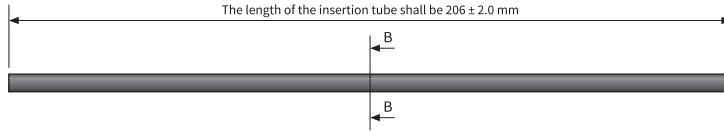

SECTION B-B
SCALE 10:1

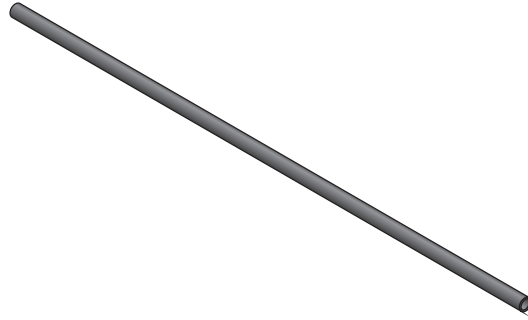

UNLESS OTHERWISE SPECIFIED
DIMENSIONS ARE IN MILLIMETERS

				DO NOT SCALE DRAWING		REVISION
				TITLE:		Insertion Tube
DESIGN	NAME	DATE				
CHKD	MPK	23.12.14				
APPVD						
RFQ						
QA				MATERIAL:	DRWG. NO.	6
				WEIGHT:		A3
					SCALE:	

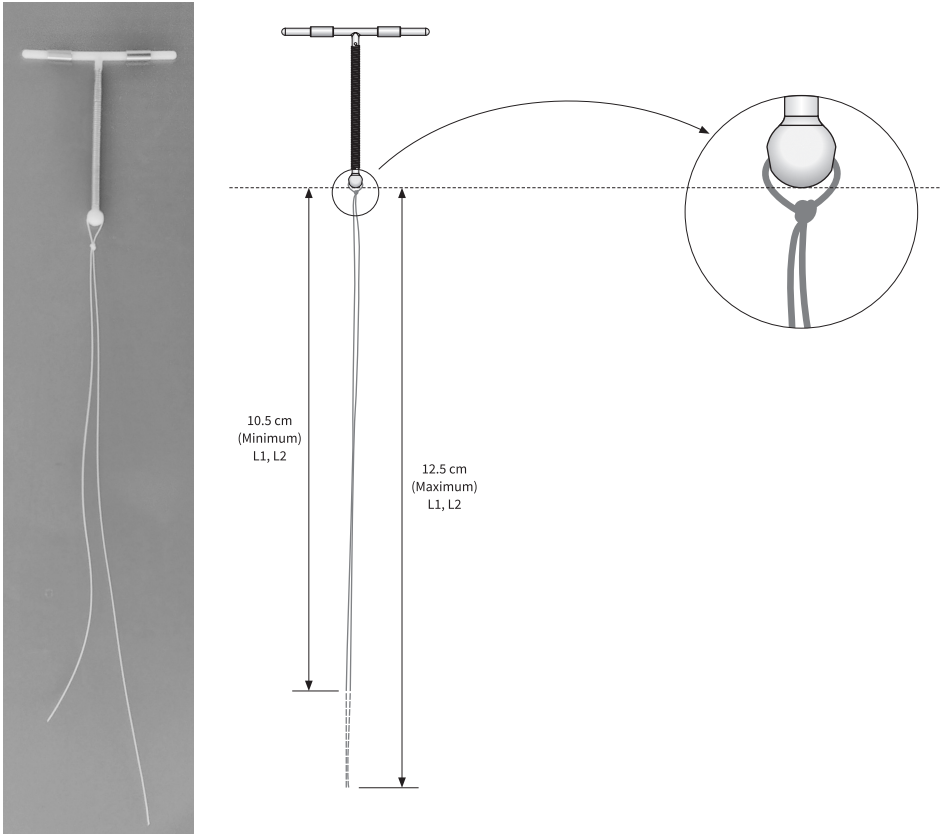

Permitted Length of each strand (i.e. L1, L2) = 105 mm – 125 mm

Note: The thread shall be knotted to form two tails of approximately equal length as shown in photograph / diagram above. After knotting the length of each straightened tail, shown as over-lapping each other in the diagram, shall be not less than 105 mm and not greater than 125 mm

Appendix 2

Guidance for bioburden control and terminal sterilization

1. Introduction and WHO/UNFPA requirement

The sterility assurance level (SAL) required in this technical specification and for the World Health Organization (WHO)/United Nations Population Fund (UNFPA) prequalification for terminally sterilized intrauterine devices (IUDs) is 1×10^{-6} . Sterility testing alone following terminal sterilization cannot provide adequate confirmation of sterility at this assurance level even when a large sample size is tested. The risk of the testing leading to false positives further rules this out as a single viable approach to verification of the achieved SAL.

Sterility assurance at this level can be achieved by real-time release testing (parametric release), which is in turn achieved by a combination of the following:

- validation and routine control of the sterilization process;
- validation, control and monitoring of the bioburden on the product.

This is the approach adopted by the sterilization standards that are required and outlined in this WHO/UNFPA TCu380A IUD technical specification and prequalification guidance document. All prequalified IUD manufacturers are required to demonstrate conformance with the International Organization for Standardization (ISO) 11737-1 requirements for establishment of acceptable limits for bioburden on a medical device based on historical data. The following text provides guidance on achieving the recommended SAL and demonstrating conformance with ISO 11737-1.

2. Sterility assurance level

The SAL is the probability of a single unit being non-sterile after it has been subjected to sterilization. The SAL shall be at least 1×10^{-6} .

3. Normative standards for sterility assurance

The following standards and guidance are recommended. The manufacturer should ensure conformance with the latest published version of the applicable standards that apply to their sterilization process and bioburden assessment test methods. The latest edition of the standards shall be used by manufacturers.

ISO 13485: Medical devices – Quality management systems – Requirements for regulatory purposes.

ISO 17665: Sterilization of health care products – General requirements for characterization of a sterilizing agent and the development, validation and routine control of a sterilization process.

ISO 11135: Medical devices – Validation and routine control of ethylene oxide sterilization.

ISO 11137-1: Sterilization of health care products – Radiation – Part 1: Requirements for development, validation and routine control of a sterilization process for medical devices.

ISO 11137-2: Sterilization of health care products – Radiation – Part 2: Establishing the sterilization dose.

ISO 11137-3: Sterilization of health care products – Radiation – Part 3: Guidance on dosimetric aspects.

ISO TS 13004: Sterilization of health care products – Radiation – Substantiation of selected sterilization dose: Method VDmaxSD.

ISO 14937: Sterilization of health care products – General requirements for characterization of a sterilizing agent and the development, validation and routine control of a sterilization process.

ISO 11737-1: Sterilization of medical devices – Microbiological methods – Part 1: Determination of a population of microorganisms on products.

ISO 11737-2: Sterilization of medical devices – Microbiological methods – Part 2: Tests of sterility performed in the definition, validation and maintenance of a sterilization process.

European Medicines Agency Committee for Medicinal Products for Human Use – Guideline on Real-Time Release Testing (formerly Guideline on Parametric Release). EMA/CHMP/ QWP/811210/2009-Rev1 (2012).

4. Sterilizer process validation

Prequalified manufacturers of IUDs are required to use terminal sterilization facilities that are certified to ISO 13485 and are in conformance with the applicable sterilization standards appropriate for the sterilization of IUDs, such as ISO 11137 for radiation sterilization or ISO 11135 for ethylene oxide sterilization. Radiation is often considered the preferred sterilization method for IUDs, despite the potential adverse effects radiation may have on some materials. Radiation permits the use of impermeable packaging pouches made of

a film–film layer combination that can reduce the risk of compromising sterility compared to the use of gas permeable pouches made of film–gas permeable synthetic layer combinations that are required for ethylene oxide (or other gas) terminal sterilization methods.

The principles of sterilizer process validation and control are similar for radiation, ethylene oxide and other sterilization methods, but this guidance focuses on radiation sterilization for the above-mentioned reasons. In most cases, radiation sterilization is subcontracted to a service provider and, in such cases, it is important to note that the IUD manufacturer is responsible for a high degree of control over the service provider.

Terminal radiation sterilization standards provide at least two methods of establishing the applicable radiation dose. In the first method, the sterilization dose is set based on knowledge of the number of microorganisms comprising the bioburden on the product and their resistance to radiation. In the second method, the dose is fixed at a defined level (such as 25 kilogray (kGy) or 15 kGy) and the primary manufacturer has to substantiate that the selected sterilization dose is capable of achieving the specified requirements for sterility.

Of the two methods, using a fixed dose (such as 25 kGy) is widely used for medical devices and is preferred for the terminal sterilization of TCu380A IUDs. This dose is widely used within the industry and has been established over many years of use as being safe and effective. If the dose is changed, then validation by the methods specified in the appropriate standards would be required to confirm that the sterility, safety and effectiveness of the IUDs are not compromised. A prequalified TCu380A IUD manufacturer would also have to obtain the prior agreement from UNFPA for the change by submitting a validation protocol and a report supporting the change for review by an appropriate technical expert.

Validation of the sterilization process is specified in the applicable sterilization standards (such as for radiation in ISO 11137-1 and for ethylene oxide in ISO 11135-1).² Periodic process validation of the sterilizer by the operator or supplier and reports of these validations are required. The prequalified IUD manufacturer is expected to monitor this to obtain and maintain copies of the validation reports and to review them as part of supplier evaluation and control. The IUD manufacturer should include these validation reports in any audits of the sterilization supplier that they carry out. Typically, the frequency of such full audits is between one and two years, not more.

² See section 9 of both ISO 11137-1: Sterilization of health care products – Radiation, and ISO 11135: Medical devices – Validation and routine control of ethylene oxide sterilization.

5. Sterilizer process control

The standards provide details on the routine monitoring and control of sterilization processes. For radiation sterilizers, this includes the use of chemical dosimeters.³ Biological indicators, such as bacterial spore strips, and chemical indicators are used for process control of ethylene oxide and other gas sterilizers.⁴ All aspects of the effective use of these dosimeters or indicators should be appropriately monitored by the IUD manufacturer for product release and as part of their routine auditing of the supplier. Confirmation of the acceptable levels of sterilizer monitoring should be included in any audits of the sterilization supplier by the IUD manufacturer.

The IUD manufacturer should review and monitor the other routine controls of the sterilizer specified in the standards. For example, ISO 11137-1 requirements can include the following.

- Sterilization dose audits can be conducted to monitor the continued effectiveness of the established sterilization dose and the resistance of the product bioburden to radiation (Clause 12.1.1).
- The frequency of sterilization dose audits shall be based on review and records of the manufacturing process, the control and monitoring procedures for the manufacturing process and, particularly, manufacturing steps that may affect the product bioburden or its resistance (Clause 12.1.3).
- The time interval between dose audits can only be increased if four consecutive dose audits show no change or if the bioburden has remained stable in number and type (Clause 12.1.3.2).
- The maximum dose audit interval is typically one year (Clause 12.1.3.3).
- A dose audit must be completed for every batch if the batch manufacturing interval is greater than the specified dose audit interval (Clause 12.1.3.4).

Manufacturers should note the requirement that “radiation sensitive visual indicators shall not be used as proof of adequate radiation processing or as the sole means of differentiating irradiated products from non-irradiated products”⁵ in respect of terminal radiation sterilization.

³ See section 10 of both ISO 11137-1: Sterilization of health care products – Radiation, and ISO 11135: Medical devices – Validation and routine control of ethylene oxide sterilization.

⁴ ISO 11135: Medical devices – Validation and routine control of ethylene oxide sterilization.

⁵ See ISO 11137-1: Sterilization of health care products – Radiation – Clause 10.4.

Maintaining process effectiveness is specified differently for each terminal sterilization method.⁶ In general, the sterilization standards specify that knowledge of the bioburden on the product is required for conformance according to the standard. The IUD manufacturer shall make it clear to the operator of the sterilization facility that terminal sterilization is a process of joint responsibility. For terminal sterilization by radiation operating according to the standard, monitoring of bioburden is required at a maximum interval of three months (or less over time based on historical data),⁷ but it is recommended by UNFPA that every lot should be tested for bioburden.

6. Product bioburden validation

Manufacturers must maintain product bioburden levels below the validated limit for the sterilization process. This is achieved by a combination of process validation and control.

6.1 Scope of process bioburden validation

Bioburden validation of the product shall encompass all of the processes that can directly affect product bioburden. This will include the manufacturing process and manufacturing steps that affect bioburden or its resistance; control and monitoring procedures for the manufacturing process; the manufacturing environment, particularly the extent of microbiological control and monitoring and available data on the stability of the manufacturing environment over time; and the controls on the health, cleanliness and clothing of personnel in the manufacturing area and all other good manufacturing practice (GMP)-related procedures. Therefore, product bioburden cannot be validated in isolation from the process validation and control of those processes that directly affect it.

6.2 Development of “alert” (“warning”) and “action” levels for product bioburden

Acceptable limits for bioburden shall be specified on the basis of previously generated data and shall be documented. If these limits are exceeded, corrective action shall be undertaken. It is therefore recommended that process control of bioburden should be based on setting “alert” (or “warning”) and “action” levels.⁸

⁶ See section 12 of ISO 11137-1: Sterilization of health care products – Radiation, ISO 11135: Medical devices – Validation and routine control of ethylene oxide sterilization, and ISO 14937: Validation and routine control of any alternative sterilization process.

⁷ See 12.1.2.1 of ISO 11137-1: Sterilization of health care products – Radiation.

⁸ Winters M, Patch E, Wangsgard W, Ferry A, Bushar H. Establishing bioburden alert and action levels. Nelson Laboratories; 2017.

This is considered best practice in the medical device industry. As part of bioburden validation, therefore, manufacturers should establish these limits from historical bioburden data.

In order to establish these levels, it is necessary to characterize the distribution of the bioburden and its variability and obtain appropriate statistically based limits from the data.

The distribution of the product bioburden is established from historical data and more frequent sampling than the recommended quarterly maximum for routine monitoring.⁹ Product bioburden samples should be representative of the manufacturing environment and should include, as far as reasonably practicable, samples from just before any routine fumigation or other key environmental maintenance operations, and the loading of the environment with personnel should reflect normal production levels. Using standard deviations of the data is considered to be a safe assumption that does not necessitate prior consideration of the normality of the data.¹⁰

In common with normal quality assurance procedures, the alert level can be set at two times the standard deviation and the action level at three times the standard deviation, and a limit at 10 times the expected or mean level after the correction factor has been applied (see below). The alert level can be set at two standard deviations from the expected mean level, since 95.44% of all measurements should fall in this range, and the action level set at three standard deviations, since 99.73% of all measurements should fall in this wider range, assuming that there has been no shift in the mean.

For established radiation doses, the measured bioburden levels should be compared with the product bioburden limit values specified in the standard.¹¹

6.3 Correction factor for recovery of microorganisms

ISO 11137-1 (the bioburden standard) requires that during method validation a correction factor is determined based on the recovery efficiency of the removal of active microorganisms from the product in the process of determining product bioburden.¹²

This correction factor is required before the statistics from product bioburden can be safely translated into out-of-specification limits, to include alert (warning) and action limits.

⁹ See 12.1.2.1 of ISO 11137-1: Sterilization of health care products – Radiation.

¹⁰ Winters et al. 2017.

¹¹ See ISO 11137-2: Sterilization of health care products – Radiation, Table 5 – Radiation dose (kGy) required to achieve a given SAL for an average bioburden ≥ 1.0 having the standard distribution of resistances.

¹² See ISO 11737-1: Sterilization of medical devices – Microbiological methods – sections 3.3, 7.2(b) and C.2.

Examples of how to determine the alert (warning) and action levels are provided by Winters et al. (see footnote to section 6.2 of this appendix).

7. Product bioburden process control

UNFPA recommends that product bioburden be measured on every lot of product prior to sterilization.

When using the recommended sterilization dose of 25 kGy, ISO 11137-1 states that product is tested for bioburden prior to sterilization at least every three months (Clause 12.1.2.2). If the interval between manufacturing of batches is greater than three months, then every batch must be bioburden tested (Clause 12.1.2.4).

7.1 Existence of outliers in product bioburden data

The existence of bioburden outliers should be considered and it is recommended that these are investigated before acceptance for inclusion in or exclusion from the product bioburden data. If the investigation identifies a problem with the process, this should be investigated and remedied before bioburden limits are set.

7.2 Purpose and use of alert (warning) levels

The main purpose of the alert level is to trigger investigation of the process so that control can be maintained without necessarily triggering corrective actions or raising issues of product conformity and acceptability for terminal sterilization. The levels may be significantly lower than the limits set in the applicable standard. They are provided to indicate the possibility of significant changes in the process. The purpose of alert (warning) levels is to enable the process control to be effective in preventing excursions of product bioburden that could potentially compromise the defined level of sterility assurance.

7.3 Purpose of action levels

The main purpose of the action level is to trigger corrective actions and raise issues of product conformity and acceptability for terminal sterilization. The purpose of the action level is to address the risk of releasing a non-sterile product.

For example, the limits given in the radiation standard¹³ and the statistic of 10 times the expected bioburden level are directly related to the risk of product being non-sterile. Product bioburden results at or above 10 times the expected value limit but well below the limits in the standard must be investigated so

¹³ See ISO 11137-2: Sterilization of health care products – Radiation, Table 5 – Radiation dose (kGy).

that the source of contamination can be identified and assessed. Depending on the source, type and distribution of bioburden, terminal sterilization at the established dose might still be acceptable subject to satisfactory verification that the radiation dose is still effective.

8. Parametric release

Sterility assurance by post-sterilization sterility testing of a sample of sterilized product is completely inadequate. UNFPA therefore requires parametric release based on a documented procedure according to The European Agency for the Evaluation of Medicinal Products.¹⁴

¹⁴ Committee for Medicinal Products for Human Use (CHMP) – Guideline on Real Time Release Testing (formerly Guideline on Parametric Release). EMA/CHMP/ QWP/811210/2009-Rev1 (2012).

Appendix 3

Guidance for stability studies

1. Introduction and WHO/UNFPA requirements

Stability studies are performed on medical devices to estimate their shelf-life under specified storage conditions and permit product expiry dates to be calculated. When conducting stability studies, it is essential that fully finished products in their final packaging are used. Changes in packaging can have an impact on the shelf-life of many products. Terminally sterilized products must have been subjected to the full sterilization cycle. Radiation sterilized products must have been subjected to the maximum dose for the maximum period of time specified in the standard operating procedures for the product.

In the case of copper-bearing intrauterine devices (IUDs), manufactures must specify the “insert before date”. This is the date from the time of manufacture to the end of the shelf-life period derived from stability studies. This confirms that the IUDs will continue to meet all the requirements of this World Health Organization (WHO)/United Nations Population Fund (UNFPA) TCu380A IUD technical specification up to the time of insertion.

A product's shelf-life can be estimated using accelerated studies but, for most products, it is necessary to confirm the results of accelerated studies by conducting long-term stability studies at the intended storage temperature. These studies are normally called real-time stability studies. The storage conditions for real-time studies have to be determined in advance. The concepts of mean kinetic temperature and world climatic zones, which are discussed in the next section, are extremely useful aids for selecting the storage conditions for real-time studies. Both real-time and accelerated stability studies must be carried out on a minimum of three lots.

2. Real-time stability studies

Real-time stability studies are conducted under a fixed set of storage conditions for the full lifetime of the product. Samples are tested periodically, usually annually, to confirm that they remain in conformance with the specification. Many characteristics of a product will not change during the storage period, whereas other will. It is therefore necessary to identify the critical performance measurements that might change and that could, in the event of any change, affect the safety and effectiveness of the product. These critical performance measurements need to be monitored during the stability study to ensure that they remain within the specified limit.

For the TCu380A IUD, the critical performance requirements listed below have been identified:

- T frame breaking strength
- thread tensile strength
- viscoelastic recovery (memory)
- collar retention force.

Since IUDs are sterile devices, it is also essential to monitor the integrity of the individual pouches during real-time stability studies. Any failure of the pouch could compromise the sterility of the device.

The critical individual pouch measurements that need to be monitored are:

- individual pouch integrity
- individual pouch peel strength.

These requirements have to be monitored on a periodic basis during the real-time stability study to assess if significant changes are occurring as the study progresses. If these properties deteriorate to a level where the product may no longer meet specification, the shelf-life limit may have been reached.

An extremely useful concept used in the pharmaceutical sector for determining the temperature at which real-time stability studies should be conducted is the mean kinetic temperature (*I*). This is a single derived temperature that, if maintained over a defined period, affords the same thermal challenge to a pharmaceutical product as would be experienced over a range of both higher and lower temperatures for an equivalent defined period. The mean kinetic temperature for a particular storage location can be calculated given knowledge of periodic temperature variations. Many modern temperature data loggers can automatically measure the mean kinetic temperature over a period of time.

Another extremely useful concept from the pharmaceutical sector for determining the conditions for conducting real-time stability studies is the division of the world into a set of four climatic zones, each with its own defined mean kinetic temperature and average humidity (*I*). Based on these zones, WHO and the International Council for Harmonisation of Technical Requirements for Pharmaceuticals for Human Use (ICH)¹⁵ have developed guidelines for conducting long-term (that is, real-time) stability studies for pharmaceutical

¹⁵ The International Council for Harmonisation of Technical Requirements for Pharmaceuticals for Human Use (ICH) was originally known as the International Conference on Harmonisation of Technical Requirements for Registration of Pharmaceuticals for Human Use (created in April 1990; name change in 2015).

products (2, 3). These recommendations have been adopted by WHO/UNFPA for conducting stability studies on IUDs.

IUDs are intended for distribution and storage on a worldwide basis, with most of the public sector supply going to hot or tropical countries. Real-time stability studies should be done under the conditions specified for climatic zones III (hot and dry) and IV (hot and humid), both of which have mean kinetic temperatures of 30 °C. For these reasons, 30 °C has been set as the standard temperature for all stability studies on IUDs intended for WHO/UNFPA prequalification.

In 2006, ICH withdrew the Q1F Stability Data Package for Registration Applications in Climatic Zones III and IV because some countries wanted larger safety margins for these zones. The decision was taken to leave the definition of storage conditions for WHO climatic zones III and IV to the respective regions and WHO. As a consequence, the specified relative humidity for climatic zone IV is now determined by local and regional regulatory authorities. Many have adopted (75 ± 5) % relative humidity rather than the previously specified (65 ± 5) % relative humidity specified in ICH QF1 for climatic zone IV. More information on these changes is given in reference (3). This reference includes a list of countries that have opted to specify (75 ± 5) % relative humidity conditions. Although relative humidity is unlikely to have any effect on the properties of the IUD directly, pouch seal integrity could be affected depending on the type of polymers used to form the seal. For this reason, any new stability studies shall be conducted at (75 ± 5) % relative humidity. Studies at (75 ± 5) % relative humidity shall be initiated upon publication of this revised technical specification and guidance document. Data on studies conducted at 65% relative humidity will remain acceptable until these studies have been completed.

The real-time ageing study shall be commenced at the same time as any accelerated studies, using samples drawn from the same production lots.

The results from the real-time study shall be submitted on its conclusion to interested parties, including UNFPA, to confirm the shelf-life estimate from the accelerated ageing study. Based on real-time studies, IUD manufacturers may claim an “insert before date” up to seven years from the date of manufacture.

3. Accelerated stability studies

Accelerated ageing studies are usually carried out at elevated temperatures to force the various chemical processes that are responsible for changes to the product to proceed at a faster rate. Other accelerating factors such as light, humidity and pH can also be used.

Shelf-life estimates made at higher temperatures have to be related back to the standard storage temperature of 30 °C that has been set for real-time studies. This can often be done using the Arrhenius equation, which describes

the relationship between the rate of chemical reactions and temperature (4). The Arrhenius relationship, however, does not apply in all cases. This is why it is still essential to use real-time studies to verify shelf-life estimates from accelerated studies.

The Arrhenius equation is usually written as:

$$k_T = A \cdot e^{-E_a/RT}$$

Where:

A = constant (min⁻¹)

E_a = activation energy (J/mole)

R = universal gas constant (8.314 J • mol⁻¹ • K⁻¹)

T = absolute temperature (K)

k_T = rate constant for the degradation process (min⁻¹).

An alternate way of expressing the Arrhenius equation is:

$$\ln(k_T) = \ln(A - E_a/RT).$$

The increase in the rate of a chemical process with temperature, as described by the Arrhenius equation, is characterized by a parameter called activation energy E_a. A literature search for the activation energy of polyethylene oxidation during the induction phase, which is considered to be the most likely degradation process that could occur with the TCu380A IUD, found values ranging from 114 kilojoules (kJ)/mole to over 200 kJ/mole.¹⁶ These activation energies would lead to the rate of oxidation increasing by at least 4.7-fold (for an activation energy of 114 kJ/mole) to over 15-fold (for activation energies over 200 kJ/mole) as the temperature is raised from 20 °C to 30 °C.

The ageing periods required at different elevated temperatures to provide an equivalent degree of ageing as storage for five years at 30 °C have been estimated using the Arrhenius relationship and an assumed activation energy of 78 kJ/mole. If samples of a product that have been aged at the specified elevated temperatures for these time periods remain within specification, then it is highly probable that the shelf-life of the product exceeds five years at 30 °C. Choosing a relatively low activation energy of 78 kJ/mole to calculate the ageing periods at the different temperatures means that the estimated shelf-life will be conservative.

¹⁶ The search was conducted using the search terms "activation energy", "polyethylene" and "oxidation", using Google Scholar. Only peer-reviewed papers and publications from recognized academic institutions were included in the review.

In practice, therefore, the shelf-life is likely to be longer than five years at 30 °C if products remain in conformance with the specification at the end of each of the recommended ageing periods and the maximum permitted changes are not exceeded. A full Arrhenius analysis should allow the actual shelf-life to be estimated (see Appendix 4 for an example of the application of the Arrhenius equation to accelerated ageing data for guidance).

Given the intrinsic uncertainties inherent in the interpretation of accelerated stability studies, the latest “insert before date” has been restricted to no later than five years from the date of manufacture. For a seven-year “insert before” period to be accepted, real-time stability studies are required.

It can be shown that the time required for the physical properties to deteriorate to a specific threshold value is inversely proportional to the rate constant k_T . Plotting the natural log of the times required at different temperatures for a property, such as frame strength, to fall to the threshold value against the reciprocal of those temperatures (expressed in Kelvin) should therefore result in a straight line if the degradation process follows the Arrhenius relationship. The slope of the straight line will be equal to E_a/RT .

To facilitate a full Arrhenius analysis, the times required at different temperatures for the physical property that is being monitored to deteriorate to a specific threshold value are determined. The threshold value may be the limit for the property being tested at which the IUD will become nonconforming. Alternatively, it may be an arbitrary limit that is set for convenience, such as a fall in strength by 25%. The threshold limit should be chosen such that the time to reach this limit can be determined with a reasonably reliable degree of statistical confidence. It should also be no greater than the maximum permitted change beyond which the product is expected to become nonconforming.

The method recommended in this section for conducting stability studies is based on ISO 11346:2004: Rubber, vulcanized or thermoplastic – Estimation of lifetime and maximum temperature of use.

4. Method of conducting stability studies

4.1 Use of standard reference product

If possible, a reference product with an established shelf-life should be included in the stability study. If a change in specification, raw materials or manufacturing process has been made, then samples of the original product can be used as the reference product. In some cases, it may be appropriate to use a competitive product as a reference sample. All the reference samples shall be from the same lot and shall be within six months of the stated manufacturing date.

4.2 Equipment

ISO 188:2007: Rubber, vulcanized or thermoplastic – Accelerated ageing and heat resistance tests specifies that two methods can be used for conducting stability studies:

- method A: air-oven method using a cell-type oven or cabinet with low air speed and a ventilation of 3 to 10 changes per hour;
- method B: air-oven method using an oven or cabinet with forced air circulation by means of a fan and a ventilation of 3 to 10 changes per hour.

Ovens or conditioning cabinets should therefore comply with one of these requirements. Whichever type of oven or cabinet is used, it must be consistent from experiment to experiment and within an experiment.

The hygrometer used to monitor the relative humidity shall be accurate to $\pm 2\%$ relative humidity. The calibration of many types of hygrometer can drift significantly over time. It is essential that a calibrated instrument is used. A psychrometer may be used either for direct measurement of relative humidity or as a reference standard for the hygrometer. If a psychrometer is used, the instrument must be calibrated (see reference (5) for general advice on the selection and calibration of hygrometers).

4.3 Test items

Samples from normal production made using normal production equipment and processes (including packaging equipment) that meet all specification requirements and are within six months of the date of manufacture and sterilization shall be used in testing. Samples shall be in standard packaging.

4.4 Use of retained samples

It may be of value to consider using any retained samples that have already been stored for a significant period. These could allow comparison of real-time and accelerated ageing results. Additionally, including such samples would allow evaluation of the effect of accelerated ageing on samples that have already undergone some real-time ageing.

4.5 Test sample size

It is strongly recommended that additional samples be included in the study to allow for retests and mistakes. When estimating the number of additional samples, the manufacturer should allow for at least one retest at each temperature, using a sample size with an acceptance number of one or more.

4.6 Example test protocol

Table 7 lists a set of ageing periods at different temperatures that can be considered equivalent to storage at 30 °C for periods of one to seven years in annual increments. These periods were calculated using the Arrhenius relationship and assume an activation energy of 78 kJ/mole. The times have been rounded up to the nearest week. The relative humidity (RH) for the accelerated ageing and real-time studies shall be maintained at (75 ± 5) % RH. At elevated temperatures, a humidity of at least (75 ± 5) % RH at the ageing temperature shall be maintained.

Table 7

Ageing periods by temperature (critical individual pouch measurements)

Temperature	Ageing periods (weeks) at specified temperature (tests to be conducted)						
80 °C ^a	1	–	2	–	4	–	5
70 °C	2	3	5	6	8	9	10
60 °C	4	7	10	13	17	20	23
50 °C	8	16	23	31	39	46	54
40 °C	20	39	59	78	97	117	136
Real-time study at 30 °C	52	104	156	208	260	312	364
Shelf-life supported (years)	1	2	3	4	5	6	7

^a Due to the very high degree of acceleration seen at 80 °C, the number of time points has been reduced.

It is important to note that the ageing periods in Table 7 are estimates. They should be confirmed as part of the accelerated stability study. Appropriate combinations of these times and temperatures can be selected when designing stability studies. For example, by measuring how the critical properties of the IUD change over time at a minimum of three different temperatures, a full Arrhenius analysis of the data can be made, as described in section 3 above of this appendix. Critical performance measurements (T frame breaking strength, thread tensile strength, memory and collar retention force) should be measured at each time interval for the specific temperatures selected. In order to be able to use the Arrhenius method for analysing the data, it is important to continue the ageing periods at the selected temperatures until the properties being measured have changed by the preselected threshold amount (different thresholds can be used for different properties if necessary) or until the maximum period at the ageing temperature has been reached. It is only necessary, however, to measure the

critical individual pouch measurements (that is, pouch integrity and pouch peel strengths) at the time periods for the selected temperatures that are equivalent to five years at 30 °C to confirm a five-year shelf-life and seven years at 30 °C to confirm a seven-year shelf-life.

Table 7 also includes the recommended annual time intervals and tests required for the real-time study at 30 °C. Critical performance measurements and critical individual pouch measurements should be completed at each time point in the real-time study.

Once a full Arrhenius analysis has been conducted, the time periods can be recalculated based on the actual activation energy derived from the Arrhenius relationship. This makes it easier to carry out further stability tests if necessary; for example, following changes to the product, manufacturing process or packaging, a further Arrhenius analysis is unnecessary and a single temperature can be selected from the amended table to verify shelf-life claims.

4.7 Measurements

Strength measurements are carried out using the amended “arms-up” method outlined in the technical specification. The IUD frame in the arms-up configuration and the thread (suture) shall be tested independently. Elongation at break shall be recorded and reported.

Results shall be produced from a portion of the original sample immediately before ageing to establish the baseline from which changes are measured.

Biocompatibility and sterility measurements should not be repeated.

4.8 Significant change

All test results shall be in conformance with this revised WHO/UNFPA TCu380A IUD technical specification using the sampling plan specified.

Any results failing to comply with the specification or showing 25% or greater change from the initial values shall be deemed significant.

A 25% or greater fall in IUD frame strength, thread strength or pouch peel strength shall be taken as an indication that the acceptable shelf-life of the product and individual pouch has been exceeded, even if these properties comply with the specification.

4.9 Tarnishing

Tarnishing can be expected. If it occurs, it should be noted. There is no evidence that tarnishing affects the shelf-life or performance of the product but excessive tarnishing could cause the product to be rejected by the purchaser or end user.

5. Test results reporting

5.1 Test results

Results shall be reported for the real-time and accelerated ageing product at all the temperatures and times specified. Sample sizes, environmental and ageing conditions, equipment and test methods shall all be referenced.

Records shall be included on any features of note, such as effects on the packaging and product, whether or not reflected in the results; and any testing conditions or events, whether or not it is believed that they affected the results.

The results shall be evaluated statistically and reported in terms of the estimated shelf-life, with associated estimates of uncertainty.

5.2 Sample estimates

Sample sizes shall be equal to or greater than 13. The sample mean and standard deviation shall be reported as well as the number of nonconforming samples.

6. Estimating the shelf-life

Depending upon the outcome of the stability study, different procedures can be used to estimate the shelf-life of the product.

6.1 No significant changes are seen in the critical performance measurements at the maximum recommended storage time at each ageing temperature

In this case, it will not be possible to estimate the actual shelf-life of the product, but the maximum time periods have been selected on a very conservative basis to provide a high level of confidence that the shelf-life is in excess of five years at 30 °C if no changes are seen during the accelerated study. If there are no significant changes, it can be concluded with a high degree of confidence that the shelf-life is in excess of five years.

6.2 Significant changes are seen in the critical performance measurements at three or more ageing temperatures, but these are below 25%

As long as significant changes are seen at three or more of the temperatures chosen for the stability study, then a full Arrhenius analysis can be carried out as described in ISO 11346. For full details on how to do this, refer to ISO 11346. Briefly, the natural logarithms of the times required at each temperature for the critical performance measures to deteriorate to the selected threshold value are plotted against the reciprocals of each temperature (expressed in Kelvin). Appropriate extrapolation methods may be used at each temperature to determine the time to reach the threshold values.

If a linear Arrhenius plot is obtained, then it will be possible to estimate the shelf-life at 30 °C with a reasonable degree of confidence by determining the time required for the critical performance measures to decrease by 25% or reach the specified threshold values, whichever occurs earlier. It may be necessary to estimate these times by extrapolation (projecting the curve or line beyond the limits of the data) or interpolation (projecting between data points).

If the Arrhenius plot is not linear, then consider using the procedure associated with the Williams-Landel-Ferry time-temperature superposition equation as described in ISO 11346 (assistance will probably be required to do this analysis).

6.3 A critical performance measurement deteriorates by 25% or more within the time periods specified in Table 7

If a critical performance measurement does not comply with the specification or falls below 25% of the initial value before the maximum duration in weeks at any given temperature, then the shelf-life of the product may be less than five years at 30 °C. An Arrhenius plot should be constructed using 25% as the threshold limit for deterioration and an appropriate shelf-life calculated. In some cases, it is expected that the estimated shelf-life will be less than five years at 30 °C, but this depends upon the actual activation energy estimated from the Arrhenius plot and whether the plot is linear. It is possible that some degradation processes may occur only at the higher temperatures used in the study and, therefore, not contribute to deterioration of the product under normal storage conditions. If a very marked temperature-dependent effect is observed, then validation of the provisional shelf-life estimate by a real-time study becomes particularly important.

References

1. Grimm, W. Storage conditions for stability testing in the EC, Japan and USA: the most important market for drug products. *Drug Development and Industrial Pharmacy*. 1993;19(20):2795–830.
2. ICH Q1A (R2): Stability testing of new drug substances and products. International Council for Harmonisation of Technical Requirements for Pharmaceuticals for Human Use (ICH) (formerly International Conference on Harmonisation of Technical Requirements for Registration of Pharmaceuticals for Human Use); 2003.
3. Stability testing of active pharmaceutical ingredients and finished pharmaceutical products. In: WHO Expert Committee on Specifications for Pharmaceutical Preparations: forty-third report. WHO Technical Report Series No. 953, Annex 2. Geneva: World Health Organization; 2009.
4. Arrhenius S. Über die Reaktionsgeschwindigkeit bei der Inversion von Rohrzucker durch Säuren [About the rate of reaction in the inversion of cane sugar by acids]. *Zeitschrift für Physikalische Chemie*. 1889;4:226 and 1899;31:187.
5. World Meteorological Organization. Guide to meteorological instruments and methods of observation, seventh edition. WMO; 2008.

Applicable standards

ASTM F1980-07: Standard guide for accelerated ageing of sterile barrier systems for medical devices.

EN 455-4: Medical gloves for single use – Part 4: Requirements and testing for shelf-life determination.

ISO 188: Rubber, vulcanized or thermoplastic – Accelerated ageing and heat resistance tests.

ISO 7439: Copper-bearing intrauterine devices.

ISO 10012: Measurement management systems – Requirements for measurement processes and measuring equipment.

ISO 11346: Rubber, vulcanized or thermoplastic – Estimation of life-time and maximum temperature of use.

ISO 13485: Medical devices – Quality management systems – Requirements for regulatory purposes.

WHO Working document QAS/06.179 (restricted). Stability testing of active substances and pharmaceutical products.

Appendix 4

Application of the Arrhenius equation to accelerated ageing data

1. Background

This annex provides an example of how to conduct an Arrhenius-based analysis of stability data for a medical device. The data do not specifically apply to the TCu380A intrauterine device (IUD) and are used as an example only.

For many chemical reactions, the rate at which the reaction occurs varies with temperature according to the Arrhenius equation:

$$k_T = Ae^{-E_a/RT} \quad (1)$$

Where A is a constant, E_a is the activation energy, R is the gas constant (8.31432 J/°K/mole) and T is the absolute temperature. k_T is the rate constant for the particular chemical reaction concerned at temperature T . It can be shown that the time required for a reaction to reach a specified threshold, say 20% completion, is inversely proportional to the rate constant k_T . This applies whatever the order of the reaction is. The Arrhenius equation can therefore be rewritten in terms of the time required to reach a specified threshold, $t_{(x\%)}$, as:

$$C/t_{(x\%)} = Ae^{-E_a/RT}, \quad (2)$$

where C is a constant. Taking logs of both sides and rearranging equation (2) gives us equation (3):

$$\ln(t_{(x\%)}) = E_a/RT - \ln(A/C) \quad (3)$$

If it is assumed that there is a direct relationship between the underlying chemical changes and the observed change in the physical property being observed, then equation (3) also models the time required for that physical property to reach a specified threshold.

If the Arrhenius equation is applicable, then it follows from equation (3) that a straight line will be obtained by plotting $\ln(t_{(x\%)})$ against $1/T$ (°K). Assuming that a straight line is obtained, then it is very easy to extrapolate the line and determine time required for the predetermined degree of change to occur at the target storage temperature. The activation energy E_a can be readily calculated from the slope of the line, recognizing that:

$$\text{Slope} = E_a/RT \quad (4)$$

2. Estimating the time required to reach a specified threshold value

The first stage in preparing an Arrhenius plot is to determine how long it takes at each temperature for the physical property under investigation to reach a predetermined threshold. Ideally, the threshold value should represent the maximum change that can be tolerated before the medical device is at risk of failing the specification. This may not always be possible, particularly at lower temperatures and with stable materials. The difference between initial and threshold values should nevertheless be sufficiently large compared to the background variability to allow the time to be estimated accurately. It may be necessary to extrapolate data obtained at lower ageing temperatures in order to determine the time to reach the threshold value. Fig. 8. illustrates how this is done, assuming the threshold limit is set at 80% of the initial value. In this particular example, linear extrapolation of the 50 °C data was required to reach the 80% threshold.

Fig. 8

Estimating the time to 80% of initial value

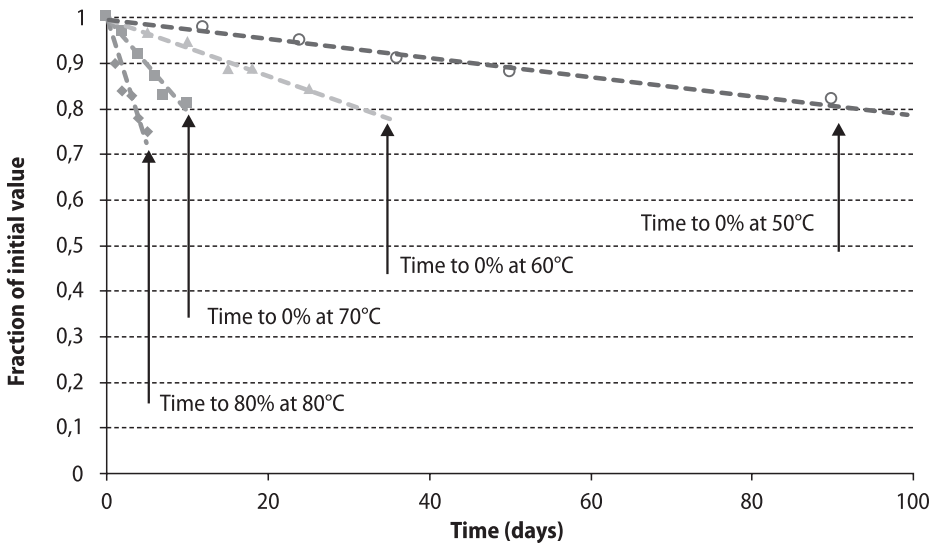

Note: Estimating the time to reach a specified threshold is often easier if linear regression methods can be used to fit a straight line through the data. In order to do this, it may be necessary to apply an appropriate transformation to the data first. Many chemical processes follow first-order kinetics, such as, the rate of change is proportional to the instantaneous value of the variable under consideration. If the rate of change of a specific property follows first-order kinetics, then a straight line can be obtained by plotting the natural log (\ln) of the property against time.

Note: In some ageing processes, sudden changes in the rate of degradation can occur, for example when all the antioxidant is consumed. If it is necessary to extrapolate data to determine the time required to reach the specified threshold, then consideration should be given to the possibility of such effects.

3. Constructing the Arrhenius plot and estimating the activation energy

The Arrhenius plot is constructed by plotting the natural logs of the times required for the property under investigation to reach the specified threshold value ($\ln(tx\%)$) against the reciprocal of the absolute temperature. A typical plot is shown in Fig. 9.

Fig. 9
Arrhenius plot based on time to reach of 80% of initial value

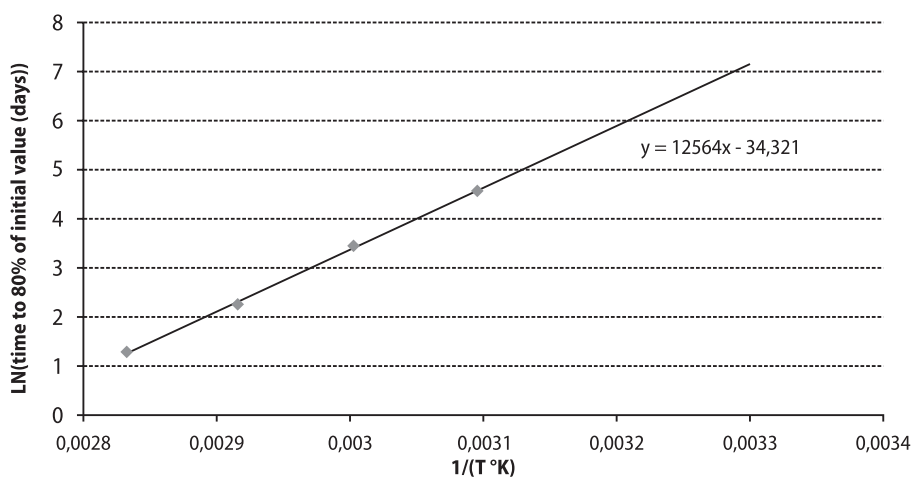

Note: The time estimated for the property under investigation to fall to 80% from Fig. 2 is 1267 days at 30 °C. The activation energy is calculated as 104.5 kJ/mole.

In some cases, the Arrhenius plots may not be linear. Several approaches to the analysis of non-linear Arrhenius-type plots have been explored and are published in the scientific literature. It must be emphasized that any attempt to extrapolate shelf-life estimates from non-linear Arrhenius plots carries a high level of risk, and manufacturers should be conservative about any estimates made under such conditions.

Typically, activation energies for many chemical reactions average 83 kJ/mole,¹⁷ although the actual range found in practice varies widely. Published values for the activation energies associated with thermal or oxidative degradation of the material being used may be available in the scientific literature.

¹⁷ Kennon L. Use of models in determining chemical pharmaceutical stability. *J Pharm Sci.* 1964;53:815–8.

Annex 11

WHO Biowaiver List: proposal to waive in vivo bioequivalence requirements for WHO Model List of Essential Medicines immediate-release, solid oral dosage forms

1. Introduction and background	404
2. WHO solubility classification for biowaiver	404
3. Scope	405
4. Methodology	405
5. Results	406
References	412



1. Introduction and background

The World Health Organization (WHO) recognizes the possibility of waiving in vivo bioequivalence studies for immediate-release, solid oral dosage forms with active pharmaceutical ingredients (APIs) belonging to classes I and III according to the Biopharmaceutical Classification System (BCS), using comparative dissolution studies as surrogate proof of bioequivalence (1).

The WHO solubility classification, also referred to as the WHO Biowaiver List, is a tool for national regulatory authorities and pharmaceutical manufacturing companies, suggesting medical products that are eligible for a waiver from in vivo bioequivalence studies, which are usually necessary to establish the therapeutic equivalence with the originator (comparator). For exemption from an in vivo bioequivalence study, an immediate-release, multisource (generic) product should exhibit very rapid or rapid in vitro dissolution characteristics that are comparable to those of the reference product. A risk-based evaluation should also account for the excipients used in the formulation of the finished pharmaceutical product.

In addition, the present list replaces the existing literature-based compilation published in 2006 that is reported in the *Proposal to waive in vivo bioequivalence requirements for WHO Model List of Essential Medicines immediate-release, solid oral dosage forms* (2) based on data extracted from the public domain (that is, solubility data published by different authors using inconsistent experimental conditions).

The WHO Biowaiver Project is organized into study cycles. Previous and current cycles are summarized below in order to provide an outline of the project development:

- 2018: cycle I, also referred to as the pilot phase
- 2019: cycle II
- 2020: cycle III
- 2021: cycle IV – The new results presented in this updated document (in Tables A11.1 and A11.2, highlighted in bold) originate from cycle IV.

2. WHO solubility classification for biowaiver

In 2017, the Fifty-second Expert Committee on Specifications for Pharmaceutical Preparations (ECSP) recommended that the WHO Secretariat revise the existing list using verifiable laboratory data that are generated according to consistent WHO criteria. Acting on this directive from the ECSP, the WHO Secretariat initiated a multicentre research project, the Biowaiver Project, aimed at experimentally determining the equilibrium solubility profile of medicines

listed in the WHO Model List of Essential Medicines, using a harmonized approach (3).

To classify APIs according to the BCS framework, two critical properties are usually evaluated: (a) an API's aqueous solubility; and (b) its absorption or permeability. The initial phase of the WHO Biowaiver Project centres on unambiguous experimental assessment of the solubility parameter, as only highly soluble APIs are eligible for biowaiver. Once experimental solubility data are available, the exact BCS class assignment can be determined by utilizing quantitative absorption and permeability data. However, since high solubility within an aqueous environment is a necessary prerequisite for an API to be eligible for a waiver from bioequivalence studies, the current focus on solubility is justified to guide the regulatory decision.

The WHO classification should be considered a living document and is meant to be regularly updated in accordance with new quality requirements and progress in scientific development.

3. Scope

The aim of the WHO Biowaiver List is to enable an informed decision as to whether or not a waiver from in vivo bioequivalence studies could be granted safely according to the WHO guidance *Multisource (generic) pharmaceutical products: guidelines on registration requirements to establish interchangeability (1)*.

The WHO Biowaiver List is expected to promote access to standard-quality essential medicines by shortening the time required to develop a multisource (generic) product, thereby supporting optimized pharmaceutical development.

The WHO Biowaiver List has been recognized by WHO regional and country offices as a “global good” – a normative work essential to strengthening global health in WHO Member States.

4. Methodology

The WHO *Protocol to conduct equilibrium solubility experiments for the purpose of Biopharmaceutics Classification System-based classification of active pharmaceutical ingredients for biowaiver (4)* is a tool available to all participants in this research. It was developed for the purpose of providing a harmonized methodology for equilibrium solubility experiments, thereby minimizing a potential source of variability among centres and studies.

APIs studied in cycles I, II, III and IV were received primarily as in-kind donations from pharmaceutical manufacturers supporting WHO in this scientific work. Equilibrium solubility experiments were conducted by universities, official national control laboratories and WHO collaborating centres.

5. Results

Table A11.1 provides an overview of the APIs studied by WHO during cycles I, II, III and IV. The new APIs studied in cycle IV are reported in bold. Fixed-dose combination products, where all APIs contained in the combination drug product were studied as monocomponents (Table A11.1), are also reported in Table A11.2.

Table A11.1

WHO solubility classification of active pharmaceutical ingredients prioritized from the WHO Model List of Essential Medicines

Medicine ^a	Therapeutic area	Indication	Highest therapeutic dose (mg)	API PQ, EOI-PQ	WHO classification ^b
abacavir (sulfate)	Antiretrovirals	Antiretrovirals (HIV)	600	Yes	I/III
aciclovir	Antiviral medicines	Antiherpes medicines	800	No	II/IV*
amoxicillin (trihydrate)	Antibacterials	Antibiotics	3000	Yes	II/IV*
azithromycin (dihydrate)	Antibacterials	Antibiotics	2000	Yes	II/IV
cefixime (trihydrate)	Antibacterials	Antibiotics	400	No	II/IV
chloroquine phosphate	Antiprotozoal medicines	Antimalarial medicines	1000 mg salt (= 600 mg base)	No	I/III
codeine (phosphate hemihydrate)	Medicines for pain and palliative care	Opioid analgesics	60	No	I/III
cycloserine	Antibacterials	Antituberculosis medicines	1000	Yes	I/III
daclatasvir (dihydrochloride)	Antiviral medicines	Medicines for hepatitis C	60	Yes	II/IV**
darunavir (ethanolate)	Antiviral medicines	Antiretrovirals (HIV)	800	Yes	II/IV**

Table A11.1 *continued*

Medicine ^a	Therapeutic area	Indication	Highest therapeutic dose (mg)	API PQ, EOI-PQ	WHO classification ^b
dexamethasone	1. Gastrointestinal medicines 2. Immunomodulators and antineoplastics 3. Medicines for pain and palliative care 4. Corticosteroids for COVID-19 ^c	1. Antiemetic medicines 2. Acute lymphoblastic leukaemia, multiple myeloma 3. Medicines for other common symptoms in palliative care 4. Treatment of patients with severe and critical COVID-19 ^c	1, 3: 0.5 to 10 mg a day, depending on the disease being treated 2: 40 mg 4: 6 mg a day ^c	Yes	I/III**
dolutegravir	Antiviral medicines	Antiretrovirals (HIV)	50	Yes	II/IV**
doxycycline (hyclate)	1. Antiprotozoals 2. Antibacterials	1. Antimalarial medicines 2. Antibiotics (access group)	100	No	I/III**
efavirenz	Antiviral medicines	Antiretrovirals (HIV)	600	Yes	II/IV
emtricitabine	Antiviral medicines	Antiretrovirals (HIV)	200	Yes	I/III**
entecavir	Antiviral medicines	Antihepatitis medicines	1	Yes	I/III**
ethambutol (hydrochloride)	Antibacterials	Antituberculosis medicines	2000	Yes	I/III
ethionamide	Antibacterials	Antituberculosis medicines	500–1000	Yes	II/IV*

Table A11.1 *continued*

Medicine ^a	Therapeutic area	Indication	Highest therapeutic dose (mg)	API PQ, EOI-PQ	WHO classification ^b
furosemide	Cardiovascular medicines	Medicines used in heart failure	80	No	II/IV
hydroxychloroquine (sulfate)	Disease-modifying antirheumatic drugs (DMARDs)	Lupus erythematosus	600	No	I/III**
isoniazid	Antibacterials	Antituberculosis medicines	300	Yes	I/III
lamivudine	Antiviral medicines	Antiretrovirals (HIV)	300	Yes	I/III
levonorgestrel	Medicines for reproductive health and perinatal care	Oral hormonal contraceptives	1.5	Yes	II/IV*
mefloquine (hydrochloride)	Antiprotozoal medicines	Antimalarial medicines	1250 (as hydrochloride)	Yes	II/IV
methyl dopa (sesquihydrate)	Cardiovascular medicines	Pregnancy-induced hypertension	500	No	I/III
oseltamivir (phosphate)	Antiviral medicines	Influenza virus	75 (as phosphate)	Yes	I/III**
paracetamol	Medicines for pain and palliative care, antimigraine medicines	Non-opioids and nonsteroidal antiinflammatory medicines, treatment of acute attack	1000	No	I/III

Table A11.1 *continued*

Medicine ^a	Therapeutic area	Indication	Highest therapeutic dose (mg)	API PQ, EOI-PQ	WHO classification ^b
primaquine (phosphate)	Antiprotozoal medicines	Antimalarial medicines (curative treatment of <i>Plasmodium vivax</i> and <i>P. ovale</i> infections)	15	Yes	I/III
proguanil (hydrochloride)	Antiprotozoal medicines	Antimalarial medicines	200	No	I/III
pyrimethamine	Antiprotozoal medicines	Antimalarial medicines	75	Yes	II/IV
raltegravir (potassium)	Antiviral medicines	Antiretrovirals (HIV in pregnant women and in second line)	400	Yes	II/IV**
rifampicin	Antibacterials	Antituberculosis, antileprosy medicines	750	Yes	II/IV
sofosbuvir	Antiviral medicines	Medicines for hepatitis C	400	Yes	II/IV**
tenofovir disoproxil (fumarate)	Antiviral medicines	Antiretrovirals (HIV)	300	Yes	I/III**

API: active pharmaceutical ingredient; PQ: prequalification; EOI-PQ: expression of interest for prequalification.

Note: In the table, the new APIs studied in cycle IV are reported in *bold text*.

^a 22nd WHO Model List of Essential Medicines (2021) (3).

^b According to the WHO *Multisource (generic) pharmaceutical products: guidelines on registration requirements to establish interchangeability (1)*, APIs belonging to classes I and III are eligible for biowaiver. Once experimental permeability data are available, the exact class attribution will be possible (that is, either class I or class III). The present solubility characterization is already sufficient to provide an indication as to whether or not an API is eligible for biowaiver.

^c Therapeutic area indication not reported on 22nd WHO Model List of Essential Medicines (2021) but in the WHO guidance *Corticosteroids for COVID-19: living guidance (5)*.

* Change in solubility class with respect to WHO 2006 classification.

** APIs characterized for the first time within the WHO Biowaiver Project.

Table A11.2

WHO solubility classification of fixed-dose combination products prioritized from the WHO Model List of Essential Medicines

Medicine ^a	Therapeutic area	Indication	Highest therapeutic dose (mg)	API PQ, EOI-PQ	WHO classification ^b
efavirenz + emtricitabine + tenofovir disoproxil (fumarate)	Antiviral medicines	Antiretrovirals (HIV)	600 + 200 + 300	Yes	II/IV**
efavirenz + lamivudine + tenofovir disoproxil (fumarate)	Antiviral medicines	Antiretrovirals (HIV)	600 + 300 + 300	Yes	II/IV**
emtricitabine + tenofovir disoproxil (fumarate)	Antiviral medicines	Antiretrovirals (HIV)	200 + 300	Yes	I/III**

API: active pharmaceutical ingredient; PQ: prequalification; EOI-PQ: expression of interest for prequalification.

^a 22nd WHO Model List of Essential Medicines (2021) (3).

^b According to the WHO *Multisource (generic) pharmaceutical products: guidelines on registration requirements to establish interchangeability (1)*, APIs belonging to classes I and III are eligible for biowaiver. Once experimental permeability data are available, the exact class attribution will be possible (that is, either class I or class III). The present solubility characterization is already sufficient to provide an indication as to whether or not an API is eligible for biowaiver.

* Change in solubility class with respect to WHO 2006 classification.

** APIs characterized for the first time within the WHO Biowaiver Project.

Establishing a new WHO Biowaiver List that is based on unambiguous verifiable experimental solubility data is a critical project with tremendous public health implications for patients, procurers, United Nations agencies, national and regional regulatory authorities, payers, ethics committees and manufacturers worldwide. The involvement and support of WHO stakeholders and partners is highly encouraged and appreciated.

References

1. Multisource (generic) pharmaceutical products: guidelines on registration requirements to establish interchangeability. In: WHO Expert Committee on Specifications for Pharmaceutical Preparations: fifty-first report. WHO Technical Report Series No. 1003, Annex 6. Geneva: World Health Organization; 2017.
2. Proposal to waive in vivo bioequivalence requirements for WHO Model List of Essential Medicines immediate-release, solid oral dosage forms. In: WHO Expert Committee on Specifications for Pharmaceutical Preparations: fortieth report. WHO Technical Report Series No. 937, Annex 8. Geneva: World Health Organization; 2006.
3. WHO Model List of Essential Medicines, 22nd list. Geneva: World Health Organization; 2021.
4. Protocol to conduct equilibrium solubility experiments for the purpose of Biopharmaceutics Classification System-based classification of active pharmaceutical ingredients for biowaiver. In: WHO Expert Committee on Specifications for Pharmaceutical Preparations: fifty-third report. WHO Technical Report Series No. 1019, Annex 4. Geneva: World Health Organization; 2019.
5. Corticosteroids for COVID-19: living guidance. Geneva: World Health Organization; 2020 (<https://www.who.int/publications/i/item/WHO-2019-nCoV-Corticosteroids-2020.1>, accessed 5 September 2022).

Further reading

- Guidance on the selection of comparator pharmaceutical products for equivalence assessment of interchangeable multisource (generic) products. In: WHO Expert Committee on Specifications for Pharmaceutical Preparations: forty-ninth report. WHO Technical Report Series No. 992, Annex 8. Geneva: World Health Organization; 2015.
- Guidance for organizations performing in vivo bioequivalence studies. In: WHO Expert Committee on Specifications for Pharmaceutical Preparations: fiftieth report. WHO Technical Report Series No. 996, Annex 9. Geneva: World Health Organization; 2016.
- General background notes on the list of international comparator pharmaceutical products. In: WHO Expert Committee on Specifications for Pharmaceutical Preparations: fifty-first report. WHO Technical Report Series No. 1003, Annex 5. Geneva: World Health Organization; 2017.

SELECTED WHO PUBLICATIONS OF RELATED INTEREST

The International Pharmacopoeia, eleventh edition.
2022 (online)

WHO Expert Committee on Specifications for Pharmaceutical Preparations
Fifty-fifth report.
WHO Technical Report Series, No. 1033, 2021 (xvi + 304 pages)

International Nonproprietary Names (INN) for pharmaceutical substances
Cumulative List No. 17 2018 (available on CD-ROM only) and Cumulative List
No. 18 2022 (available as searchable pdf – test phase)

The selection and use of essential medicines
Report of the WHO Expert Committee (including the 22nd WHO Model List of
Essential Medicines and the 8th WHO Model List for Children),
WHO Technical Report Series, No. 1035, 2021 (xlviii + 829 pages)

WHO electronic Essential Medicines List (eEML)
World Health Organization, 2022
<https://list.essentialmeds.org/>. Licence: CC BY 3.0 IGO

WHO Expert Committee on Biological Standardization
Seventy-fifth report
WHO Technical Report Series, No. 1043, 2022 (xii + 268 pages)

To purchase WHO publications, please contact:
WHO Press, World Health Organization, 20 Avenue Appia, 1211 Geneva 27, Switzerland;
email: bookorders@who.int; order on line: <http://apps.who.int/bookorders>

The Expert Committee on Specifications for Pharmaceutical Preparations works towards clear, independent and practical standards and guidelines for the quality assurance of medicines and provision of global regulatory tools. Standards are developed by the Expert Committee through worldwide consultation and an international consensus-building process. The following new guidance texts were adopted and recommended for use:

Guidelines and guidance texts adopted by the Expert Committee on Specifications for Pharmaceutical Preparations; WHO good manufacturing practices for sterile pharmaceutical products; IAEA/WHO guideline on good manufacturing practices for investigational radiopharmaceutical products; WHO guidelines on technology transfer in pharmaceutical manufacturing; WHO good manufacturing practices for medicinal gases; WHO good practices for research and development facilities of pharmaceutical products; WHO good manufacturing practices for investigational products; Points to consider for setting the remaining shelf-life of medical products upon delivery; WHO/UNFPA guidance on natural rubber male latex condom stability studies; WHO/UNFPA technical specification for TCu380A intrauterine device; and WHO Biowaiver List: proposal to waive in vivo bioequivalence requirements for WHO Model List of Essential Medicines immediate-release, solid oral dosage forms.

All of the above are included in this report and recommended for implementation.

ISBN 9789240063822



9 789240 063822